

Piston rod brake

ROBA[®]-linearstop hydraulic
Type 380.01_.0
Sizes 10 – 40

Issue status 2016-06

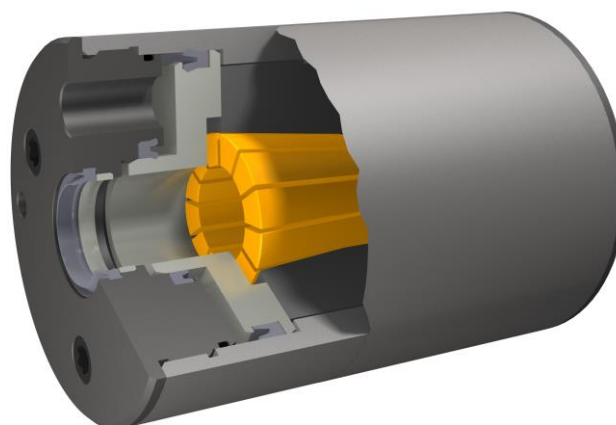

Original Operational Instructions B.380.EN

© Copyright by mayr[®] – power transmission

All rights reserved.

Reprints and copies – even extracts – are only permitted with the consent of the manufacturer.

Contents

1 General Guidelines.....	3	6.5 Brake Dimensioning	12
1.1 Definition of Terms.....	3	6.5.1 Calculation example (dynamic braking)	13
2 Safety 4		6.5.2 Switching Times	13
2.1 Safety and Guideline Signs.....	4	7 Storage.....	14
2.2 General Guidelines	4	7.1 Brake Storage.....	14
2.2.1 Personnel Requirements	4	8 Installation	15
2.3 Intended Use.....	5	8.1 Installation Conditions	15
2.4 Handling.....	5	8.1.1 General	15
2.5 User-implemented Protective Measures	5	8.1.2 Piston Rod	15
2.6 Dimensioning Other Machine Elements	5	8.1.3 Controls	16
3 Legal Provisions.....	5	8.2 Installation (Figs. 1 and 2)	17
3.1 Standards, Directives and Regulations Used... 5		8.2.1 Pre-requisites	17
3.2 Liability	5	8.2.2 Preparation	17
3.3 Guarantee	5	8.2.3 Bleed	17
3.4 Guidelines	5	8.2.4 Installation Procedure	17
3.5 Identification/ Type tag	6	9 Options	18
4 Product Description	7	9.1 Switching Condition Monitoring	18
4.1 Scope of Delivery / State of Delivery.....	7	10 Initial Operation / Operation.....	19
4.2 Function	7	10.1 Brake Inspection (Before Initial Operation)	19
4.3 Views	8	10.2 Brake Test (initial operation).....	19
4.4 Parts List	8	10.2.1 (Static) Brake Inspection	19
5 Technical Data	9	10.3 Brake Inspection (During Operation)	19
5.1 Guidelines	9	10.3.1 Regular Function Inspection (static)	19
5.1.1 Application Conditions	9	11 Maintenance / Inspection / Switching Frequency	20
5.1.2 Ambient temperature	9	
5.1.3 Protection	9	11.1 Switching Frequency	20
5.1.4 Noise Emissions	9	11.2 Inspection	20
5.1.5 Installation Position	9	11.3 Maintenance	20
5.1.6 Pre-requisites for Product Application	9	11.4 Cleaning:	21
5.2 Technical Data	10	12 De-installation	21
5.3 Dimensions Sheet.....	10	13 Disposal	21
6 Intended Use.....	11	14 Malfunctions / Breakdowns.....	22
6.1 Guidelines for Application	11		
6.2 Limits.....	11		
6.3 Reasonably Foreseeable Misuse.....	11		
6.4 Duration of Use	11		

Please read these Operational Instructions carefully and follow them accordingly!

Ignoring these Instructions may lead to malfunctions or to brake failure, resulting in damage to other parts. These Operational Instructions are part of the brake delivery.
Please keep them handy and near to the brake at all times.





1 General Guidelines

1.1 Definition of Terms

Term	Meaning
ROBA®-linearstop	Hydraulically-actuated piston rod brake as a component for holding and deceleration of moved machine parts.
Nominal holding force F_{Nenn}	The theoretical nominal holding force assigned to the designation. The nominal holding force lies within the stated nominal holding force tolerances.
Load mass	Designation of the weight, which must be held by the brake.

2 Safety

2.1 Safety and Guideline Signs

Symbol	Signal word	Meaning
	DANGER	Designates a directly pending danger. If not avoided, death or severe injuries will be the consequence.
	WARNING	Designates a possibly hazardous situation. If not avoided, death or severe injuries will be the consequence.
	CAUTION	Designates a hazardous situation. If not avoided, slight or minor injuries can be the consequence.
	ATTENTION	Possible property damage can be the consequence.
	Please Observe	Designates tips for application and other particularly useful information. Not a signal word for dangerous or damaging situations.

2.2 General Guidelines

Brakes may generate several risks, among others:



Severe injury to people and damage to objects may result if:

- the brake is used incorrectly.
- the brake is modified.
- the relevant standards for safety and / or installation conditions are ignored.

During the risk assessment required when designing the machine or system, the dangers involved must be evaluated and removed by taking appropriate protective measures.

2.2.1 Personnel Requirements

To prevent injury or damage, only professionals and specialists are allowed to work on the devices. They must be familiar with the dimensioning, transport, installation, initial operation, maintenance and disposal according to the relevant standards and regulations.



Before product installation and initial operation, please read the Installation and Operational Instructions carefully and observe the Safety Regulations. Incorrect operation can cause injury or damage.

At the time these Installation and Operational Instructions go to print, the hydraulic brakes accord with the known technical specifications and are operationally safe at the time of delivery.

- Technical data and specifications (Type tags and documentation) must be followed.

General Guideline:

During the risk assessment required when designing the machine or system, the dangers involved must be evaluated and removed by taking appropriate protective measures in accordance with the Machinery Directive 2006/42/EC.

Brakes for safety-related applications are to be installed singly or as redundant devices in accordance with the required category, in order to fulfil the required Performance Level (PL_r) acc. EN ISO 13849. This is in principle the task of the system manufacturer.

2.3 Intended Use



Use according to the intended purpose is prohibited until it has been determined that the machine / system accords with the EC Directive 2006/42/EC (machinery directive).

mayr®-brakes are for use in machines and systems and must only be used in the situations for which they are ordered and confirmed. Using them for any other purpose is not allowed.

ROBA®-linearstop brakes by mayr® are used for holding of piston rods.

ROBA®-linearstop brakes by mayr® prevent inadvertent dropping or crashing of gravity-loaded axes.

2.4 Handling

Before installation, the brake must be inspected and found to be in proper condition. The following are not considered as being representative of a proper condition:

- Outer damage
- Outer oiling
- Outer contamination

The brake function must be inspected both **once attachment has taken place** as well as **after longer system downtimes**.

2.5 User-implemented Protective Measures

- Please cover moving parts to protect **against injury through seizure**.
- Install additional protective measures **against corrosion** if the brake is subject to extreme ambient conditions or is installed in open air conditions, unprotected from the weather.

2.6 Dimensioning Other Machine Elements



The effects of the maximum and minimum braking force on the other machine components must be observed in order to provide sufficient dimensioning. The ROBA®-linearstop has (at room temperature) a maximum braking force of 2,5 x brake nominal holding force and a minimum braking force of 1 x brake nominal holding force.

If other brakes are positioned behind the ROBA®-linearstop, and if the braking times of the different brakes overlap, the loads will add up.

3 Legal Provisions

3.1 Standards, Directives and Regulations Used

(also to be observed during installation and operation)

2006/42/EG	Machinery directive
EN ISO 4413	General rules and safety requirements for hydraulic systems and their components
EN ISO 12100	Safety of machinery - General principles for design - Risk assessment and risk reduction
EN ISO 13849-1	Safety of machinery – Safety related parts of control systems

3.2 Liability

The information, guidelines and technical data in these documents were up to date at the time of printing. Demands on previously delivered brakes are not valid. Liability for damage and operational malfunctions will not be taken if:

- the Installation and Operational Instructions are ignored or neglected.
- the brakes are used inappropriately.
- the brakes are modified.
- the brakes are worked on unprofessionally.
- the brakes are handled or operated incorrectly.

3.3 Guarantee

- The guarantee conditions correspond with the Chr. Mayr GmbH + Co. KG sales and delivery conditions (www.mayr.com → Service → General Terms and Conditions)
- Mistakes or deficiencies are to be reported to mayr® at once!

3.4 Guidelines



Guidelines on the Machinery Directive (2006/42/EC)

The product is a component for installation into machines according to the Machinery Directive 2006/42/EC. The brakes can fulfil the specifications for safety-related applications in connection with other elements. The type and scope of the required measures result from the machine risk analysis. The brake then becomes a machine component and the machine manufacturer assesses the conformity of the safety device to the directive.

It is forbidden to start use of the product until you have ensured that the machine accords with the regulations stated in the directive.

Guidelines on the ATEX Directive

Without a conformity evaluation, this product is not suitable for use in areas where there is a high danger of explosion.

For application of this product in areas where there is a high danger of explosion, it must be classified and marked according to Directive 2014/34/EU.

3.5 Identification/ Type tag

mayr® components are clearly marked and described on the Type tag:

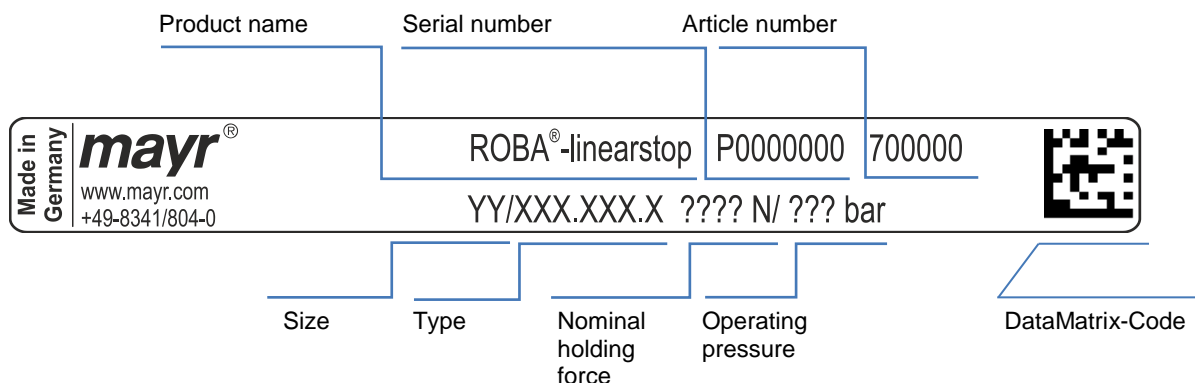

Serial number

Year	Code
2000	A
2001	B
2002	C
2003	D
2004	E
2005	F
2006	H
2007	J
2008	K
2009	L
2010	M
2011	N

Year	Code
2012	P
2013	R
2014	S
2015	T
2016	U
2017	V
2018	W
2019	X
2020	A

4 Product Description

4.1 Scope of Delivery / State of Delivery

- ROBA®-linearstop brakes are manufacturer-assembled and ready for installation.
- The ROBA®-linearstop is set to the nominal holding force stipulated in the order.
- Please observe the Type tag.
- Please check the state of delivery immediately! *mayr*® will take no responsibility for belated complaints. Please report transport damage immediately to the deliverer. Please report incomplete delivery and obvious defects to the manufacturer.

CAUTION Please observe the own weight of the brake



The brake may drop during lifting / transport.

This might lead to crushing or bruising, e.g. of the foot.

4.2 Function

The spring-loaded, enclosed **ROBA®-linearstop**, which can be opened hydraulically, clamps a piston rod steplessly and backlash-free.



Please Observe!

The maximum clamping force can only be reached when the brake is pressureless.

Due to the spring-loaded system, the fail-safe principle can be guaranteed, the **ROBA®-linearstop** works as a **safety brake**.

The required operating pressure is stated on the Type tag.



Please Observe!

In case the operating pressure is too low, the brake cannot be pressurised correctly.

- Through pressurization of the **ROBA®-linearstop** with the required operating pressure, the clamping element of the brake is pressed against the spring. The piston rod can be moved (Illustration 1).
- By pressure release the **ROBA®-linearstop**, the spring has an effect on the clamping element of the brake. The piston rod is clamped (Fig. 2).

The max. permitted sliding speed is 2 m/s.

Higher speeds on request!



Please Observe!

Before pressure relief of the brake, the collet must enclose the piston rod completely.

If the piston rod ends in the collet, the clamping element might get damaged when actuating the brake!

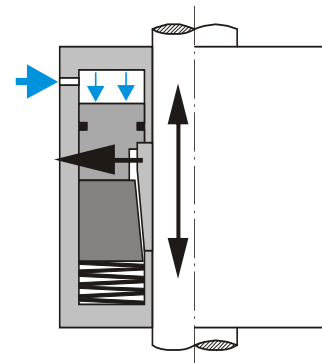

Illustration 1 Moveable piston rod on pressurization

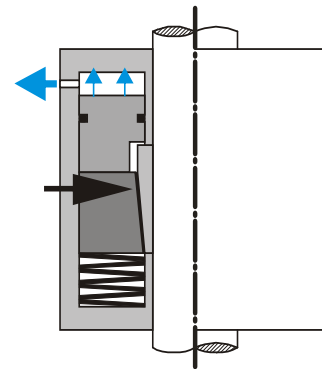

Illustration 2 Clamped piston rod on pressure release

Operational Instructions for ROBA®-linearstop Type 380.01_0 Sizes 10 - 40

(B.380.EN)

4.3 Views

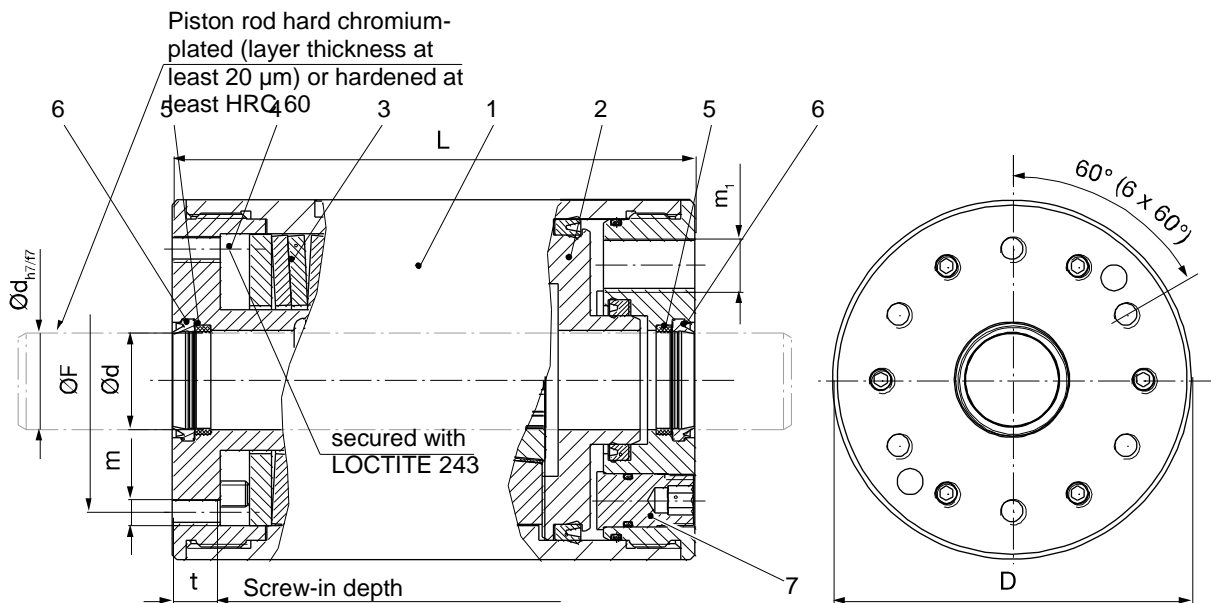

Fig. 1

Fig. 2

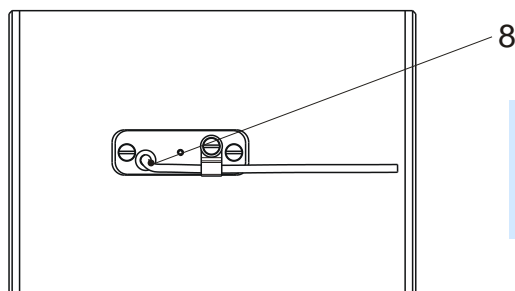

Fig. 3



All brake seals are made of NBR.

4.4 Parts List

(Only use *mayr*® original parts)

Item	Name
1	Housing
2	Piston
3	Cup spring
4	Set screw
5	Plain bearing
6	Double dirt wiper
7	Emergency release screw
8	Switching condition monitoring (option dependent on Type)
8.1	Proximity switch
8.2	Cap screws
9	Type tag (not depicted)
10	Guideline sign for emergency release screw (not depicted)

5 Technical Data

5.1 Guidelines

5.1.1 Application Conditions



The stated values are guideline values which have been determined in test facilities. It may be necessary to carry out your own tests for the intended application.

When dimensioning the brakes, please remember that installation situations, permitted friction work and braking distances as well as general ambient conditions can all affect the given values.

- Mounting dimensions and connection dimensions must be adjusted according to the size of the brake at the place of installation.
- Use of the brake in extreme environmental conditions or outdoors, directly exposed to the weather, is not permitted.
- The surfaces of the outer components have been phosphated manufacturer-side to form a basic corrosion protection. For brake applications outdoors where the device is subject to weather influences or extreme environmental conditions, additional protective measures, such as for example protective paint, must be provided.
- The provision of the required operating pressure must be guaranteed.

5.1.2 Ambient temperature

-10 °C up to +60 °C, non-condensing

5.1.3 Protection

(mechanical) IP54: When installed, dust-proof and protected against contact as well as against water spray from any direction (dependent on customer-side mounting method).

5.1.4 Noise Emissions

Normally no noise development

5.1.5 Installation Position

The ROBA®-linearstop can be operated in any installation position.

5.1.6 Pre-requisites for Product Application

Compare the limit values stated in these operational instructions with the actual application, e.g.

- Pressure
- Clamping forces
- Braking distance
- Masses
- Temperatures etc.

Operational Instructions for ROBA®-linearstop Type 380.01_.0 Sizes 10 - 40

(B.380.EN)

5.2 Technical Data

Technical Data			Size															
			10				20				30				40			
Nominal holding force F_{Nenn} (minimum holding force)	[kN]		4	6	8	10	8	12	16	20	20	25	30	35	35	40	45	50
	min.	[bar]	35	40	50	60	40	50	60	70	50	55	65	75	55	60	65	70
Operating pressure	max.	[bar]	150				150				160				160			
		[kg]	4.9				11				14.7				26.8			
Hydraulic connection thread	m1		1/4"				3/8"				3/8"				3/8"			
Tightening torque against limit stop	Emergency release screw (7)	[Nm]	10															
Pressure medium			Use hydraulic oil acc. DIN 51524-1:2006-04															
Absorption volume		[cm ³]	4				7				11				15			
Ambient temperature		[°C]	-10 to +60															

¹⁾ Minimum holding force when the brake is not pressurised and when the brake rod is dry or moistened with mineral oil.

5.3 Dimensions Sheet

Dimensions [mm]		Size			
		10	20	30	40
D		91	112	140	170
d		30	30	40	50
F		63	82	115	135
L		131	163	172	189
m		6 x M8	6 x M8	6 x M10	6 x M16
t		14	14	14	25

6 Intended Use

See also section 2.3

6.1 Guidelines for Application

- Please observe the correct dimensioning of clamping force and switching frequency at an EMERGENCY STOP for safe holding of the mass and safe compliance of the required brake path.
- Static application
 - Holding and clamping in case of power failure
 - In case of pressure drop
 - EMERGENCY STOP
- Application in clean environments (penetration of coarse dust and liquids such as oils can have a negative effect on the clamping / braking function).
- Application in enclosed buildings (in tropical regions, in high humidity and temperatures below 0 °C with long downtimes, and sea climates only after taking special measures).

Please contact *mayr*® power transmission.

6.2 Limits

- The brake is not suitable for use in severely contaminated environments
- The brake is not suitable for application in high ambient temperatures >60 °C
- Brake is not suitable for use in liquid media
- Brake is not suitable for use in a vacuum
- Brake is not suitable for contact with abrasive media (e.g. abrasive and grinding dust)
- Brake is not suitable for contact with aggressive, corrosive media (e.g. solvents, acids, lyes, salts etc.)
- Brake is not suitable for contact with foodstuffs

6.3 Reasonably Foreseeable Misuse

The following uses are prohibited and may generate hazards.

- Any opening of the screws on the housing.
- The maximum switching frequency is exceeded
- Brake is used in heavily contaminated surroundings

6.4 Duration of Use

20 years or on reaching the T10d (for definition, see EN ISO 13849-1) duration of use.

6.5 Brake Dimensioning

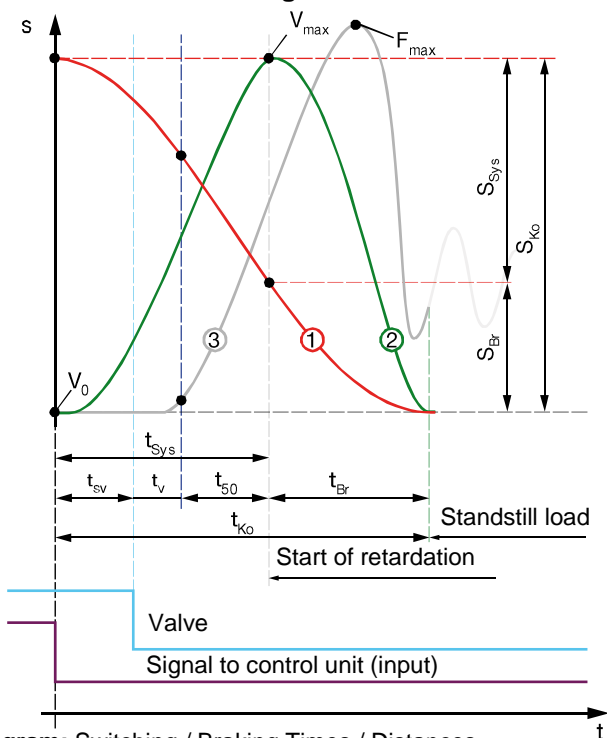

Diagram: Switching / Braking Times / Distances

Name

1		Distance
2		Speed
3		Axial force
β	[°]	Angular position 0° (horizontal) to 90° (vertical)
a_B	[m/s ²]	Acceleration of the downward-moving load, dependent on the angular position
a_v	[m/s ²]	Retardation
g	[m/s ²]	Gravitational acceleration (9.81 m/s ²)
F_{Br}	[N]	Braking force for dynamic calculation
$F_{erf.}$	[N]	Required holding force
F_{Nenn}	[N]	Nominal holding force (minimum holding force)
F_{NGes}	[N]	Total nominal holding force (one or more brakes)
F_{max}	[N]	Maximum holding force
m	[kg]	Load mass
S_{Br}	[m]	Braking distance: Distance from the beginning of the retardation up to the standstill of the load
S_{Sys}	[m]	System distance: Distance travelled by the load until the retardation begins.
S_{Ko}	[m]	Stopping distance: Distance from the signal interruption up to standstill of the load
t_{50}	[s]	Brake switching time
t_v ¹⁾	[s]	Valve switching time (not applicable for Type 382.0 _ _ _)
t_{sv}	[s]	Switching time control unit (signal processing time)
t_{Sys}	[s]	System switching time
t_{Br}	[s]	Brake braking time

General

When selecting the brake, the nominal holding force must be greater or equal to the required holding force.

$$F_{Nenn} \geq F_{erf.} \quad [N]$$

Dimensioning for dynamic braking (EMERGENCY STOP)

For safety reasons, at least the weight load of the masses to be held +100 % reserve must be provided.

The larger the ratio of the nominal holding force to the required holding force, the shorter the stopping distance (for the same technical conditions)

The minimum required holding force can be calculated with the following formula:

$$F_{erf.} = \frac{m \times g}{0.5} \quad [N]$$

Dimensioning for static holding (clamping)

For safety reasons, at least the minimum weight load of the masses to be held +20 % reserve must be provided.

The minimum required holding force can be calculated with the following formula:

$$F_{erf.} = \frac{m \times g}{0.8} \quad [N]$$

The stopping distance / stopping time of the load to be braked is strongly dependent on the following influences:

- Switching time control unit (signal processing)
- Switching time of the control valve ¹⁾
- Switching time of the brake
- Cross-section and length of the lines

The larger the sum of the switching times, the later the retardation of the load occurs (due to longer periods of acceleration). The stopping distance / the stopping time becomes longer (with constant holding force).

Name

t_{Ko}	[s]	Stopping time: Time from the signal interruption up to standstill of the load
V_0	[m/s]	Initial speed
V_{max}	[m/s]	Maximum speed

If you have any questions, please contact **mayr®** power transmission.

Operational Instructions for ROBA®-linearstop Type 380.01_0 Sizes 10 - 40

(B.380.EN)

6.5.1 Calculation example (dynamic braking)

Data		
Angular position piston rod	β	= 90° (vertical axis)
Mass	m	= 800 kg
Initial speed	V ₀	= 0.5 m/s
Valve switching time	t _v	= 0.016 s
Switching time control system	t _{sv}	= 0.020 s
Existing operating pressure		= 80 bar

1. Pre-selection of braking force

$$F_{\text{erf.}} = \frac{m \times g}{0.5} \quad [\text{N}]$$

$$F_{\text{erf.}} = \frac{700 \times 9.81}{0.5} = 15696 \quad [\text{N}]$$

Selected: ROBA®-linearstop Size 20, Type 380.00_0
Nominal holding force F_{Nenn} = 20000 N at 80 bar operating pressure
(from section 5.2 Fehler! Verweisquelle konnte nicht gefunden werden. Table "Technical Data")

2. Calculation of the stopping distance/stopping time

Checking the selected brake size

Acceleration of the load

$$a_B = g \times \sin(\beta) = 9,81 \times \sin(90^\circ) = 9.81 \quad \left[\frac{\text{m}}{\text{s}^2} \right]$$

System distance

$$S_{\text{Sys}} = V_0 \times t_{\text{Sys}} + a_B \times t_{\text{Sys}}^2 \times 0.5 \quad [\text{m}]$$

$$S_{\text{Sys}} = 0.5 \times 0,081 + 9.81 \times 0.081^2 \times 0.5 \quad [\text{m}]$$

$$S_{\text{Sys}} = 0,073 \quad [\text{m}]$$

$$t_{\text{Sys}} = t_{50} + t_v + t_{sv} = 0,045 + 0,016 + 0.02$$

$$t_{\text{Sys}} = 0.081 \quad [\text{s}]$$

Braking distance

$$S_{\text{Br}} = \frac{V_{\text{max}}^2}{2 \times \left(\frac{F_{\text{NGes}}}{m} - a_B \right)} \quad [\text{m}]$$

$$S_{\text{Br}} = \frac{1,29^2}{2 \times 15.19} = 0,055 \quad [\text{m}]$$

$$V_{\text{max}} = V_0 + a_B \times t_{\text{Sys}} \quad [\text{m/s}]$$

$$V_{\text{max}} = 0.5 + 9.81 \times 0.081 = 1.29 \quad [\text{m/s}]$$

Stopping distance

$$S_{\text{Ko}} = S_{\text{Br}} + S_{\text{Sys}} \quad [\text{m}]$$

$$S_{\text{Ko}} = 0.055 + 0.073 = 0.128 \quad [\text{m}]$$

Stopping time

$$t_{\text{Ko}} = t_{\text{Br}} + t_{\text{Sys}} \quad [\text{s}]$$

$$t_{\text{Ko}} = 0.085 + 0.081 = 0.166 \quad [\text{s}]$$

$$t_{\text{Br}} = \frac{V_{\text{max}}}{\frac{F_{\text{NGes}}}{m} - a_B} = \frac{1.29}{15.19} = 0.085 \quad [\text{s}]$$

Retardation (for system dimensioning)

$$a_v = \frac{F_{\text{NGes}} \times 2.5}{m - g} = \frac{20000 \times 2.5}{800 - 9.81} = 63.28 \quad [\text{m/s}^2]$$

$$\text{Load} = \frac{a_v}{g} = \frac{63.28}{9.81} = 6.45 \quad [\text{g}]$$

6.5.2 Switching Times

Switching times			Size			
			10	20	30	40
Brake switching time	t ₅₀	[s]	0.030	0.045	0.055	0.065

7 Storage

7.1 Brake Storage

- Store the brakes in dry rooms, dust and vibration-free.
- Relative air humidity < 50 %.
- Temperature without major fluctuations within a range from –30 °C up to +70 °C.
- Do not store in direct sunlight or UV light.
- Do not store aggressive, corrosive substances (solvents / acids / lyes / salts etc.) near to the brakes.

For longer storage of more than 2 years, special measures are required.

► **Please contact *mayr*® power transmission.**

8 Installation

8.1 Installation Conditions

Please observe before installation!

8.1.1 General



Please Observe!

The piston rod must only be loaded in the direction of motion.

- The brake is delivered manufacturer-assembled ready for installation



Please Observe!

Leave the brake in its installed condition!

- The nominal holding force is set manufacturer-side via pre-tensioning the cup springs (3). The set screws (4) for spring pre-tensioning are secured against turning via Loctite 243.



CAUTION The nominal holding force might be influenced.

Customer-side turning of the set screws (4) can lead to malfunctions.

Never turn the set screws.

8.1.2 Piston Rod

Requirements on the piston rod design

- For brake installation, we recommend an insertion chamfer on the piston rod of min. 3 x 20°.
- The piston rod should be installed at one end as a floating bearing.
- We recommend to stress the piston rod with tension.



Please Observe!

Please pay attention to the buckling safety on pressure-loaded piston rods!

Please observe the stroke length, the load and cylinder mounting to prevent bending or buckling of the piston rod in any stroke position.

$$F_{\max} = 2.5 \times F_{\text{Nenn}}$$



Please Observe!

The ROBA®-linearstop function can only be guaranteed on a proper rod surface.

Rod quality

Steel, hard chromium-plated	
Layer thickness	at least 20 µm
Diameter tolerance	h7 to f7
Surface quality	Ra < 0.4 µm
Yield point	min. 400 N/mm ² (e.g. C45)

or

Steel, hardened	
Hardness testing	at least HRC 60
Tolerance field	h7 to f7
Surface quality	Ra < 0.4 µm
Yield point	min. 400 N/mm ² (e.g. C45)

CAUTION



The clamping effect might get influenced by friction value-reducing materials, such as tough greasy lubricants, greases or separating agents - please clean, if necessary; see section **11.4**



Please Observe!

Check the piston rod for wear. On necessary replacement.

Inspection interval:

Approximately every 10 EMERGENCY STOP braking actions.

Operational Instructions for ROBA®-linearstop Type 380.01_.0 Sizes 10 - 40

(B.380.EN)

8.1.3 Controls

The *mayr*® transmission company recommends the following hydraulic controls.

The piston space is filled with hydraulic oil, thus suspending the spring force. The compressed air in the piston space is deduced in case of power failure. The spring force has an effect on the clamping element. The piston rod is clamped/ braked.

Recommendation:

- ❑ Pressure fluctuations can be reduced through a non-return valve.
- ❑ In order to guarantee fastest possible switching of the brake, the largest possible line diameter should be used in the area of the return flow lines. In addition, no choke valves may be installed in this area, and the hydraulic lines between the brake and the valve must be kept as short as possible.
- ❑ The size and speed of the 3/2 directional control valve (3) has an effect on the switching time.

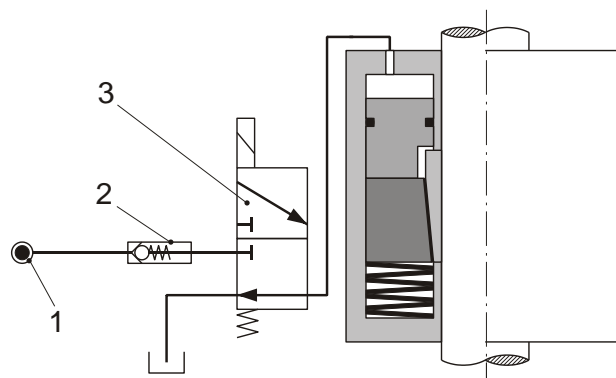

Fig. 5

Item	Name
1	Pressure source
2	Non-return valve (in case of pressure fluctuations)
3	3/2-directional control valve

8.2 Installation (Figs. 1 and 2)

8.2.1 Pre-requisites

- Unpack the brake
- Check for completeness
- Check the data on the Type tag
- Visual inspection (e.g. after longer storage period)



CAUTION Please observe the own weight of the brake
The brake may drop during lifting / disassembly. The consequences may be crush injuries and impact injuries.

8.2.2 Preparation

- Have the necessary tools ready:
 - Spanners etc.
 - Torque wrenches
- Provide fixing screws (not included in the standard scope of delivery)

Fixing screw sizes and tightening torques				
Sizes	Thread	Tightening torque	Property class	Screw-in depth t
10	6 x M8	24 Nm	8.8	14 mm
20	6 x M8	24 Nm	8.8	14 mm
30	6 x M10	48 Nm	8.8	14 mm
40	6 x M16	36 Nm	10.9	25 mm

All tightening torques are recommendations only. These data do not relieve the user from checking the data regarding the actual installation situation.

8.2.3 Bleed



Before installation, fill the **ROBA®-linearstop** with oil.

1. Remove the thread plug from the hydraulic connection (thread m_1)
2. Fill the brake with oil (hydraulic oil acc. DIN 51524-1:2006-04)
3. Turn the thread plug in on the hydraulic connection (thread m_1)

The (customer-side) hydraulic supply line must be bled before connecting it to the **ROBA®-linearstop**.

8.2.4 Installation Procedure



Installation of the brake onto the piston rod is possible in de-pressurised condition. The three emergency release screws (7) are screwed in up to contact (state of delivery).



WARNING Danger of load crashes
When the emergency release screws (7) are screwed in, the brake has no braking function.

- Before initial operation, turn the emergency release screws back up to contact evenly and step-wise (tightening torque to contact, see Table in Chapter **5.2**).

1. Push the brake onto the piston rod.



Please Observe!
Tilted insertion of the piston rod might cause damage to the double dirt wiper and seals.
Push the brake onto the piston rod carefully.

2. Remove the thread plug from the hydraulic connection (thread m_1)
3. Connect the hydraulic hose to the brake via thread m_1 (Fig. 1).
4. Pressurize the brake with operating pressure see technical data section **5.2**.
5. Turn the emergency release screws (7) back up to contact evenly and step-wise (tightening torque to contact, see Table in Chapter **5.2**).
6. Screw in the fixing screws (without torque).
7. Screw securement with Loctite 243
8. Switch the brake in de-pressurized state, thereby placing it under tension (centring).
9. Tighten the fixing screws using the torque (see table in section **8.2.2**)

9 Options

9.1 Switching Condition Monitoring

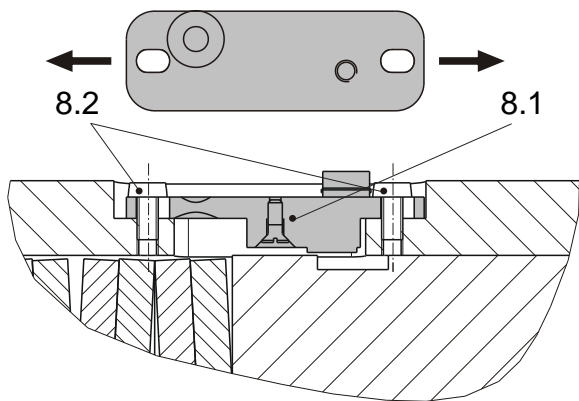

Fig. 6



Please Observe!
The switching condition monitoring is installed and set manufacturer-side.

A proximity switch (8.1) emits a signal for every brake condition change.

Plausibility check

Brake opened	Pressure switched on	Signal "OFF"
Brake closed	Pressure switched off	Signal "ON"

The customer is responsible for a signal evaluation of both conditions.

Wiring Diagram:

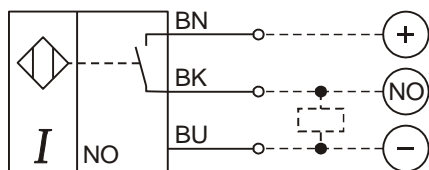

Technical Data	
PNP/NO contact	
Rated operating voltage:	$U_e = 24 \text{ VDC}$
Operating voltage:	$U_B = 10 \dots 30 \text{ VDC}$
Rated operating current	$I_e = 100 \text{ mA}$
Cable length:	5000 mm

Replacement of the proximity switch



Please Observe!
Proximity switches cannot be guaranteed fail-safe. Therefore, please ensure appropriate access for replacement or adjustment.

Pre-requisites

- Load must be secured (e.g. on vertical axes).

WARNING Load crash possible



Gravity loaded axes must be secured before beginning the work: this secures them against dropping.

- Brake is pressureless (enclosed) on the piston rod.

De-installation

1. Screw on the cap screws (8.2), remove the proximity switch (8.1) including the bracket support
2. Screw on the countersunk screw, remove the proximity switch (8.1)

Installation and Adjustment

Initial position: Proximity switch is not connected

Activity	Result
1. Check whether the brake is de-pressurized	
2. Apply the proximity switch (8.1) assembly including the bracket support lightly using two cap screws (8.2) so that the proximity switch (8.1) can still be moved.	
3. Connect the proximity switch (see Wiring Diagram) and move it	Signal "ON"
4. Increase the brake pressure until the piston rod loosens.	
5. Change the proximity switch (8.1) position axially	Signal "OFF"
6. Secure the proximity switch (8.1) using cap screws (8.2).	
7. Reduce the pressure again	Signal "ON"
8. Increase the brake pressure until the piston rod loosens	Signal "OFF"
9. Increase the pressure of the brake to operating pressure.	
10. Carry out a functional inspection	
10.1 Switch off the pressure	Signal "ON"
10.2 Switch on the pressure	Signal "OFF"

10 Initial Operation / Operation

10.1 Brake Inspection (Before Initial Operation)

- Check all fixing screws for the required tightening torque.
- Visual inspection of the hydraulic connections and lines.
- Check for leakages (on pressurization).

10.2 Brake Test (initial operation)

CAUTION



During the Brake Test danger to personnel and damage to machines cannot be ruled out in case of malfunctions (incorrect installation, control errors etc.).

Do not enter the danger zone.

Possibly take measures for catching or damping the load.

Check dimensioning!

10.2.1 (Static) Brake Inspection

- On vertical axes, a brake inspection is carried out via load assumption or via the drive.



Recommendation!

Test the brake using the nominal holding force or the maximum load mass.

10.3 Brake Inspection (During Operation)



Recommendation!

A test must be carried out to guarantee the necessary holding force with all control and brake times if a risk is generated by gravity-loaded axes. A cyclic brake inspection during running operation provides additional safety. Depending on the danger, please observe the respective regulations and standards.

10.3.1 Regular Function Inspection (static)

- Depending on the application requirements, we recommend carrying out regular braking force inspections (depending on the application), e.g. check the static holding force 1 x per shift with nominal holding force or with maximum load mass.
- In addition to the regular inspection of the holding force, we recommend the application of a switching condition monitoring device (option), in order to request the brake switching condition or to prevent a possible load crash on vertical installation.



Recommendation!

The holding force may be reduced by friction value-reducing materials. If the brake during the functional inspection does not achieve the nominal holding force, repeat using 90 % of the nominal holding force and clean the piston rod at the next opportunity (see section **11.4**).

Operational Instructions for ROBA®-linearstop Type 380.01_.0 Sizes 10 - 40

(B.380.EN)

11 Maintenance / Inspection / Switching Frequency

11.1 Switching Frequency

The ROBA®-linearstop is designed for a switching frequency of up to 1 million switching actions.



At a switching frequency > 200.000, a reduction in nominal holding force of -20 % must be expected.

11.2 Inspection

Check the condition

Measure	Condition		Interval	Implementation
Visual inspection	Double dirt wiper	The double dirt wipers must not show any signs of wear, as otherwise there might be a risk of dirt penetration.	To be determined by machine operator depending on the installation situation ► Please contact <i>mayr</i> ® power transmission.	Qualified personnel
	Hydraulic	Check that the connections and connection lines are leak-proof.		
	Piston Rod	Check the piston rod for wear. Replace in case of wear.	Approximately every 10 EMERGENCY STOP braking actions.	
	Wear indicators	Nominal holding force is not reached (slipping). Replace brake	To be determined by machine operator depending on the installation situation ► Please contact <i>mayr</i> ® power transmission.	

11.3 Maintenance

The ROBA®-linearstop is mainly maintenance-free.

Measure	Note/comment	Interval	Implementation
Functional Inspection	Carry out a regular functional inspection	see section 10.3	Qualified personnel
Check the piston rod	The piston rod must be checked regularly for contamination with friction value-reducing materials; it must be cleaned, if necessary (see section 11.4). Special maintenance work may be necessary if the device is subject to large amounts of dirt or dust or is operating in extreme ambient conditions. Please contact the <i>mayr</i>® place of manufacture.	at least every 6 months	



Should the ROBA®-linearstop no longer meet the required characteristics or should the necessary safety for work on the machine or system no longer be given, the brake must be checked at *mayr*® transmission and, if necessary, professionally repaired and approved.

11.4 Cleaning:

Clean the piston rod using ethyl alcohol.

12 De-installation

WARNING Load crash possible



The brake must be load-free.
Please check that it is load-free before
de-installation.

- Provide security in the danger zone.
- Support the load

CAUTION Please observe the own weight of the brake



The brake may drop during lifting / dis-
assembly.

The consequences may be crush inju-
ries and impact injuries.

De-installation takes place by following the "Installation
procedure" section **8.2.4** backwards.

13 Disposal

For disposal, please observe the specific regulations of
the respective country of application.

Electronic Components (Proximity switch):

Products which have not been disassembled can be dis-
posed of under Code No. 160214 (mixed materials) or
components under Code No. 160216, or can be disposed
of by a certified disposal firm.

All steel components:

Steel scrap (Code No. 160117)

Seals, O-rings, V-seals, elastomers:

Plastic (Code No. 160119)

14 Malfunctions / Breakdowns

Malfunction	Possible Causes	Solutions	Implementation
Brake does not release	Operating pressure too low	Check operating pressure and increase if necessary	Qualified personnel
	Defective valve	Replace defective valve	
	Leakage in the oil feed line	Seal leakage	
	Changed spring pre-tensioning	Send the device	mayr® power transmission
Brake does not brake	Brake wear limit reached	Replace brake	Qualified personnel
	Defective valve	Replace defective valve	
	Piston rod too small	Check dimensioning, check technical data	
	Emergency release screws (7) not unscrewed	Unscrew emergency release screws (7)	
Delays in brake opening	Cross-section of oil feed too small	Mount line with larger cross-section	Qualified personnel
Braking distance too long	Friction value-reducing materials on the piston rod	Clean the piston rod	
	Cross-section of oil output too small / too long	Mount line with larger cross-section	
	Incorrect dimensioning	Check dimensioning, check technical data	
	Valve too slow		
Quick-action ventilating valve too small			
Brake (severely) oil-contaminated	Operating pressure too high	Check operating pressure and reduce if necessary	Qualified personnel
	Use of a hydraulic oil (aggressive) which has not been recommended by mayr® power transmission	Replace brake	
	Screw connection / oil feed line leaking	Replace screw connection or feed line	
Switching condition monitoring device does not provide signal	Incorrect assembly and adjustment of the switching condition monitoring system	Repeat adjustment process, see section 9.1	Qualified personnel
	Brake does not release	See Malfunctions → Brake does not release	
	Defective cable	Replace defective cable	
	Defective proximity switch	Replace defective proximity switch	



Mayr® transmission will take no responsibility or guarantee for replacement parts and accessories which have not been delivered by mayr®, or for damage resulting from the use of these products.