

# Installation instructions for Hand Release for ROBA-stop<sup>®</sup>-M brakes Type 891. \_ \_ \_ . \_ Sizes 2 – 500

(B.8.1.0.GB)

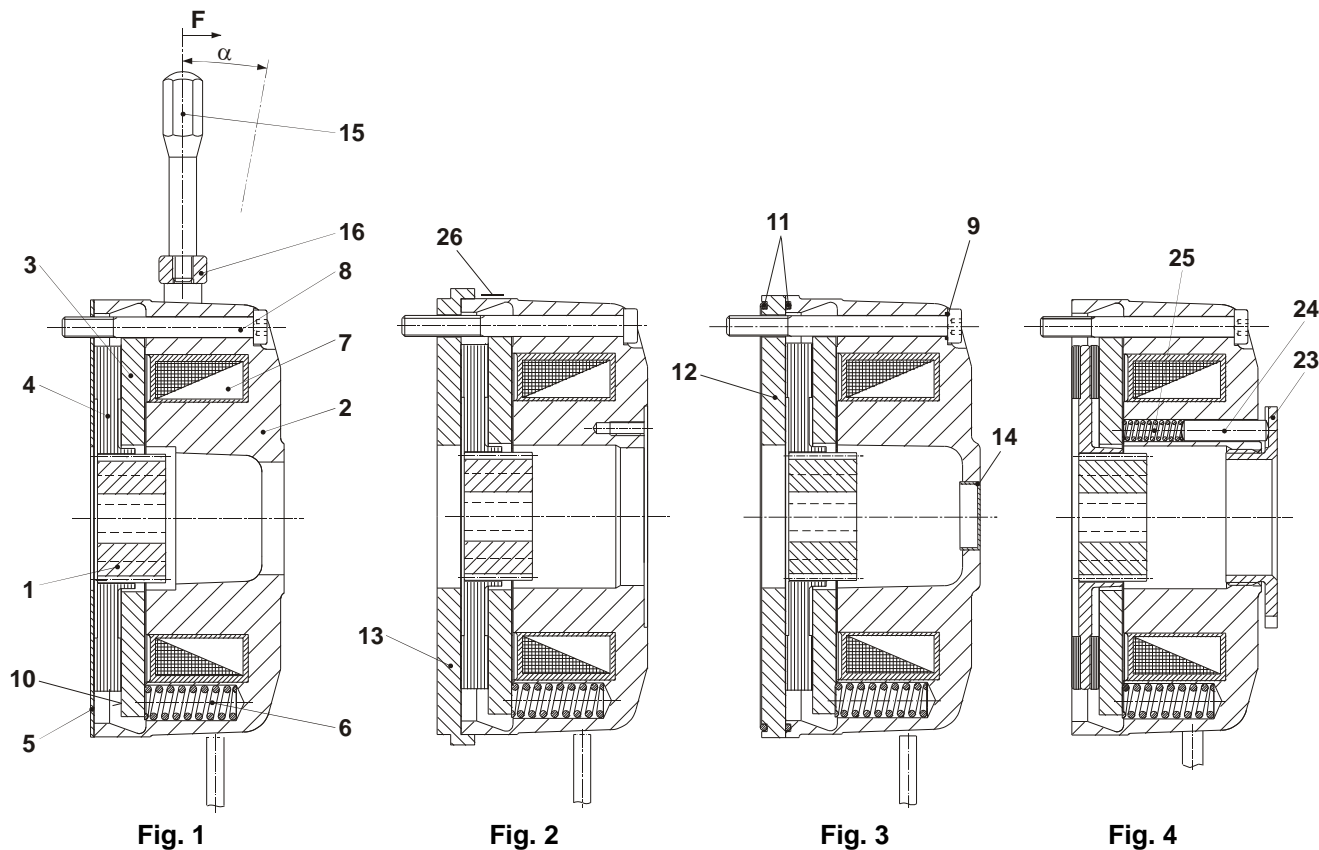

These Installation Instructions must only be used in connection with the **Installation and Operational Instructions B.8.1.GB for ROBA-stop<sup>®</sup>-M brakes**. Please observe the Safety Regulations and Protective Measures listed there. If necessary, you are welcome to download the **B.8.1.GB** from our Internet portal [www.mayr.com](http://www.mayr.com), or place a request for postal delivery.



## Parts List (Only use *mayr*<sup>®</sup> original parts)

- |  |  |
|--|--|
| 1 Hub                                      | 14 Sealing plug (only for Sizes 8 to 500)      |
| 2 Coil carrier with magnetic coil (7)      | 15 Hand release rod                            |
| 3 Armature disk                            | 16 Switch bracket                              |
| 4 Rotor                                    | 17 Threaded bolt                               |
| 5 Friction disk                            | 18 Thrust spring                               |
| 6 Thrust spring (torque)                   | 19 Hexagon nut                                 |
| 7 Magnetic coil                            | 20 Washer                                      |
| 8 Cap screw                                | 21 O-ring (Type 891._ _ _ .1)                  |
| 9 Flat sealing ring (Type 891._ _ _ .1)    | 22 Intermediate plate (Type 891._ _ _ .1)      |
| 10 Shoulder screw (not shown)              | 23 Adjusting screw (central torque adjustment) |
| 11 O-ring (Type 891._ _ _ .1)              | 24 Parallel pin (central torque adjustment)    |
| 12 Flange plate sealed (Type 891._ _ _ .1) | 25 Thrust spring (central torque adjustment)   |
| 13 Flange plate tachometer                 | 26 Type tag                                    |

# Installation instructions for Hand Release for ROBA-stop<sup>®</sup>-M brakes Type 891. \_ \_ \_ . \_ Sizes 2 – 500

(B.8.1.0.GB)

Table 1: Technical Data (Dependent on Size)

Size	Hand release force [N] with		Release angle "α" [°]	Inspection dimension "x" (Fig. 5) [mm]	Number of turns "Y" on the hexagon nuts (19) (Fig. 5)	Fixing screw Item 8 (Fig. 1)				Tighten- ing torque [Nm]
	Type 891.0/2	Type 891.1				Design without flange plate (Items 12/13)	Stan- dard	Design with flange plate (Items 12/13)	Stan- dard	
2	20	26	6	0,9 <sup>+0,1</sup>	1,7	3 x M4 x 45	2)	3 x M4 x 50	1)	2,5
4	35	45	7	0,9 <sup>+0,1</sup>	1,7	3 x M4 x 45	2)	3 x M4 x 50	1)	2,5
8	70	90	7	1,1 <sup>+0,1</sup>	1,5	3 x M5 x 50	2)	3 x M5 x 55	2)	5,0
16	100	125	7	1,6 <sup>+0,1</sup>	2,0	3 x M6 x 60	2)	3 x M6 x 65	2)	9,0
32	130	170	8	1,8 <sup>+0,1</sup>	2,0	3 x M6 x 60	2)	3 x M6 x 70	1)	9,0
60	220	300	10	2,2 <sup>+0,1</sup>	2,0	3 x M8 x 75	2)	3 x M8 x 85	1)	22
100	260	340	12	2,2 <sup>+0,1</sup>	1,6	3 x M8 x 80	1)	3 x M8 x 90	1)	22
150	290	350	13	2,2 <sup>+0,1</sup>	1,6	3 x M8 x 100	1)	3 x M8 x 110	1)	22
250	350	430	10	2,4 <sup>+0,1</sup>	1,5	3 x M10 x 110	1)	3 x M10 x 130	1)	45
500	310	470	10	2,4 <sup>+0,1</sup>	1,5	6 x M10 x 110	1)	6 x M10 x 130	1)	45

1) = DIN EN ISO 4762

2) = DIN 6912

## Hand Release Installation (see Figs. 1 and 6)

### CAUTION



For hand release installation, the brake must be dismantled and de-energised.

### Procedural Method:

- Put the thrust springs (18) onto the threaded bolts (17). The threaded bolts (17) come manufacturer-side assembled with a key as tension element and secured with adhesive up to Size M60. This connection must not be loosened.
- Push the threaded bolts (17) with thrust springs (18) from the inside (you should be facing the magnetic coil (7)) into the hand release bores in the coil carrier (2).
- Push the O-rings (21) (only on sealed hand release, Type 891.\_ \_ \_ .1/ Fig. 6) over the threaded bolts (17) and push them into the coil carrier (2) recesses. Avoid crushing the O-rings (21).
- Push the intermediate plates (22) (only on sealed hand release, Type 891.\_ \_ \_ .1 / Fig. 6) over the threaded bolts (17).
- Mount the switch bracket (16), add the washers (20) and lightly screw on the self-locking hexagon nuts (19).
- Tighten both hexagon nuts (19) until the armature disk (3) lies evenly against the coil carrier (2).
- Loosen both hexagon nuts (19) by "Y" turns (see Table 1), thereby producing an air gap between the armature disk (3) and the coil carrier (2). This gives you inspection dimension "x".



An uneven adjustment dimension on the hand release can cause the brake to malfunction.

- After installing the release cover, screw the hand release rod (15) into the switch bracket (16) and tighten it. The hand release rod (15) must be protected against loosening using a securing lacquer, e.g. Loctite 243.



The inspection dimension "x" (Figs. 5 and 6) is only used for hand release adjustment in dismantled condition.

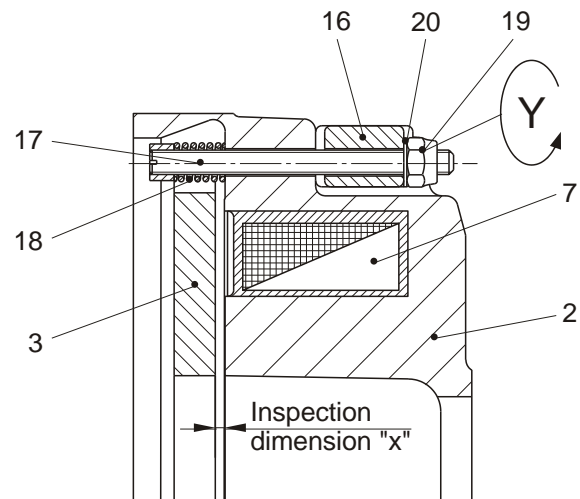

Fig. 5 Type 891.\_ \_ \_ .0/2/3

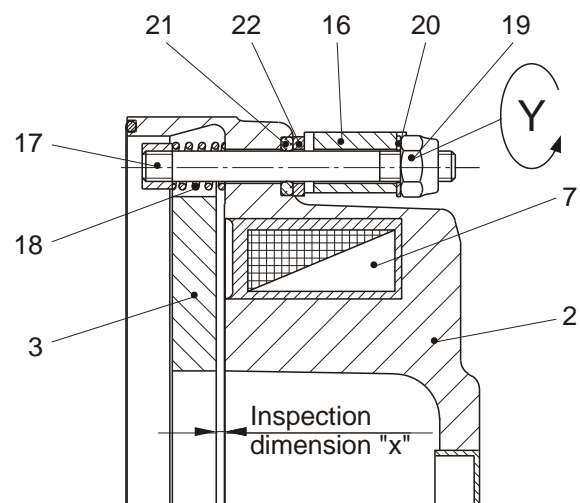

Fig. 6 Type 891.\_ \_ \_ .1