

Please read these Operational Instructions carefully and follow them accordingly!

Ignoring these Instructions may lead to malfunctions or to coupling failure, resulting in damage to other parts.

Contents:

- Page 1:** - Contents
 - Safety Regulations
 - Safety and Guideline Signs
- Page 2:** - Summary of Constructional Designs
 - Parts List
- Page 3:** - Table 1:
 - Technical Data
- Page 4:** - Tables 2 and 3:
 - Transmittable Torques on Shrink Disk Hubs
- Page 5:** - Table 4:
 - Transmittable Torques on Clamping Hubs
- Page 6:** - Function - Application
 - State of Delivery
 - Temperature Resistance
 - Installation Position
 - Guidelines on Hub Bore and Shaft
- Page 7:** - Hub Installation
- Page 8:** - Coupling Installation
 - Coupling Alignment
 - Permitted Shaft Misalignments
- Page 9:** - Balancing the Coupling
 - Diagram 1:
 - Balancing Coupling with Sleeve S/CRD/CFRP
 - Diagram 2:
 - Permitted Speeds for Sleeve S/CRD
- Page 10:** - Diagram 3:
 - Permitted Speeds for Sleeve CFRP
- Page 11:** - Maintenance
 - Disposal
 - Malfunctions / Breakdowns

Safety and Guideline Signs

CAUTION



Danger of injury to personnel and damage to machines.



Please Observe!
Guidelines on important points.



According to German notation, decimal points in this document are represented with a comma (e.g. 0,5 instead of 0.5).

Safety Regulations

These Installation and Operational Instructions (I + O) are part of the coupling delivery. Please keep them handy and near to the coupling at all times.



It is forbidden to start use of the product until you have ensured that all applicable EU directives and directives for the machine or system into which the product has been installed have been fulfilled. At the time these Installation and Operational Instructions go to print, the ROBA[®]-DS couplings accord with the known technical specifications and are operationally safe at the time of delivery. Without a conformity evaluation, this product is not suitable for use in areas where there is a high danger of explosion. This statement is based on the ATEX directive.

CAUTION



- If the ROBA[®] DS couplings are modified.
- If the relevant standards for safety and / or installation conditions are ignored.

User-implemented Protective Measures

- Cover all moving parts to protect against seizure, dust or foreign body impact.
- Replace self-locking hexagon nuts when they become ineffective after frequent loosening and tightening.

To prevent injury or damage, only professionals and specialists should work on the devices, following the relevant standards and directives. Please read the Installation and Operational Instructions carefully before installation and initial operation of the device.

These Safety Regulations are user hints only and may not be complete!

Installation and Operational Instructions for ROBA®-DS couplings Type 95²/₃ (Disk Pack HT) Sizes 16 - 160

(B.9.7.2.GB)

Summary of Constructional Designs

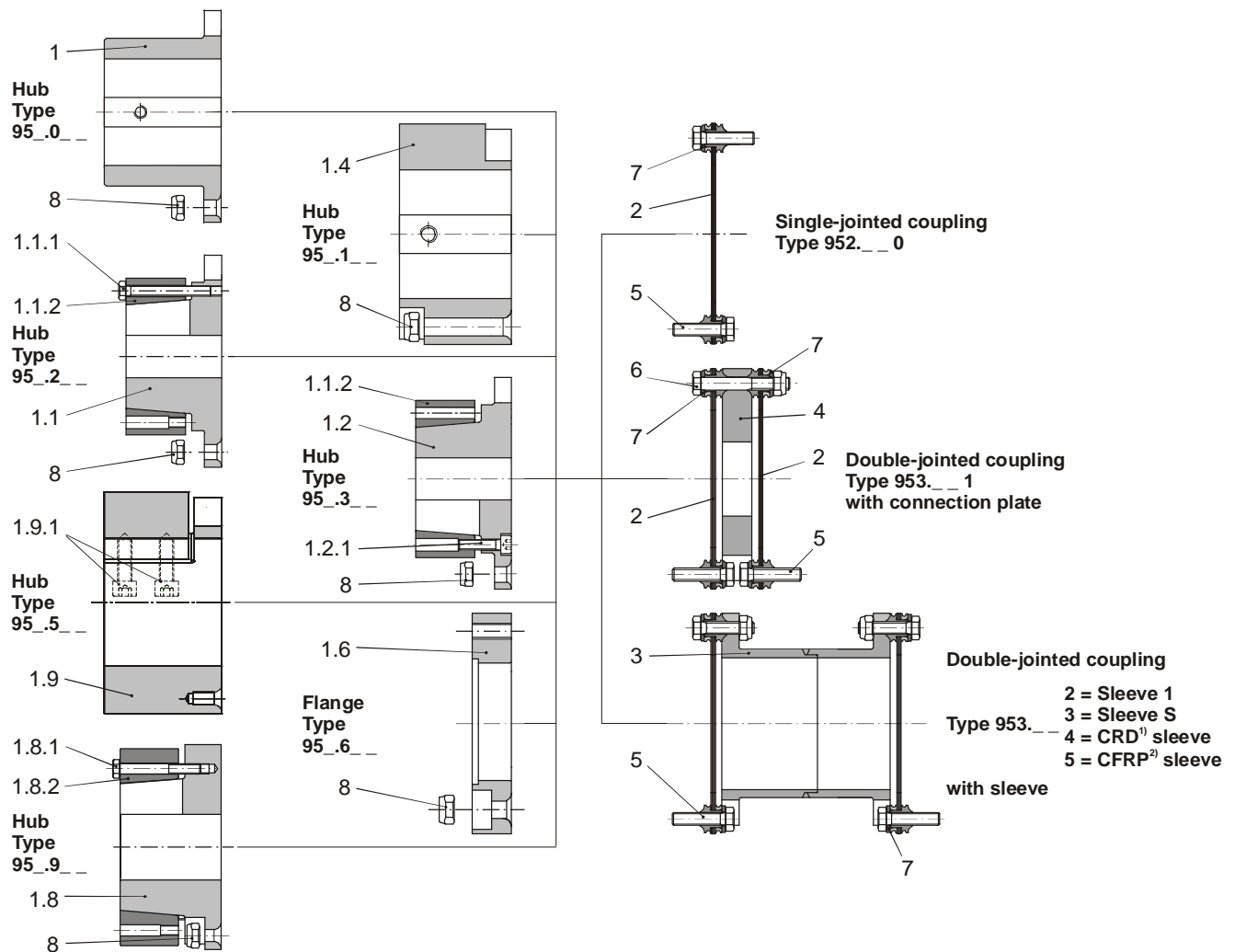

¹⁾ CRD = cranked
²⁾ CFRP = carbon fibred reinforced plastic

Fig. 1

Parts List

Only use *mayr*® original parts

- | | | | |
|-------|--|---|--------------------|
| 1 | Hub Type 95_0__ | 2 | Disk pack |
| 1.1 | Hub Type 95_2__ | 3 | Sleeve |
| 1.1.1 | Hexagon head screws for hubs Type 95_2__ | 4 | Connection plate |
| 1.1.2 | Shrink disk | 5 | Hexagon head screw |
| 1.2 | Hub Type 95_3__ | 6 | Hexagon head screw |
| 1.2.1 | Cap screws for hubs Type 95_3__ | 7 | Washer |
| 1.4 | Hub Type 95_1__ | 8 | Hexagon nut |
| 1.6 | Flange Type 95_6__ | | |
| 1.8 | Hub Type 95_9__ | | |
| 1.8.1 | Hexagon head screws for hubs Type 95_9__ | | |
| 1.8.2 | Shrink disk | | |
| 1.9 | Hub Type 95_5__ | | |
| 1.9.1 | Cap screws for hubs Type 95_5__ | | |

Installation and Operational Instructions for ROBA®-DS couplings Type 95²/₃ (Disk Pack HT) Sizes 16 - 160 (B.9.7.2.GB)

Table 1: Technical Data

ROBA®-DS Size	16	25	40	64	100	160		
d _{Pmax} Hub Type 95_0 (1) [mm]	32	40	50	55	70	80		
d _{Gmax} Hub Type 95_1 (1.4) [mm]	45	55	65	75	95	110		
d _{Smax} Hub Type 95_2/3 (1.1/2) [mm]	26	36	45	45	55	65		
d _{Rmax} Hub Type 95_5 (1.9) [mm]	45	52	60	70	90	100		
d _{SGmax} Hub Type 95_9 (1.8) [mm]	45	52	60	70	90	100		
Coupling nominal torque T _{KN} valid for alternating loads as well as for max. permitted shaft misalignment [Nm]	300	420	650	1100	1600	2600		
Coupling impact torque T _{KS} valid for one rotational direction, max. load cycles ≤ 10 ⁵ [Nm]	450	630	975	1650	2400	3900		
Max. speed n _{max.} [rpm]	13600	11800	10100	8500	7300	6200		
Distance dimension "S" [mm]	4,6 ±0,2	5,0 ±0,2	6,1 ±0,2	8,0 ±0,25	8,6 ±0,25	9,2 ±0,25		
Axial displacement ΔK _a Values refer to couplings with 2 disk packs. Only permitted as static or virtually static value. [mm]	±0,8	±0,9	±1,1	±1,3	±1,5	±1,7		
Radial misalignment ΔK, for Type 953_1 [mm]	0,2	0,2	0,25	0,3	0,3	0,35		
Radial misalignment ΔK, for Type 953_2 [mm]	0,7	0,8	1	1,25	1,45	1,5		
Radial misalignment ΔK, for Types 953_3/4/5 [mm]	(H _s - S) x 0,0122							
Radial misalignment for single-jointed coupling	With only one disk pack, the shafts must be aligned exactly.							
Angular misalignment ΔK _w per disk pack [°]	0,7	0,7	0,7	0,7	0,7	0,7		
Hexagon head screws Item 1.1.1 (Hub Type 95_2_) Tightening torque [Nm]	M5x30 6	M5x35 6	M5x40 8,5	M6x45 10	M8x50 25	M8x55 25		
Cap screws Item 1.2.1 (Hub Type 95_3_) Tightening torque [Nm]	M5x18 6	M5x18 6	M5x20 8,5	M6x20 10	M8x22 25	M8x25 25		
Hexagon head screws Item 1.8.1 (Hub Type 95_9_) Tightening torque [Nm]	M5x30 6	M5x35 6,5	M5x40 8,5	M6x45 14	M8x50 25	M8x55 32		
Cap screws Item 1.9.1 (Hub Type 95_5_) Tightening torque [Nm]	M6x25 17,4	M8x25 42	M10x35 83	M12x40 122	M12x45 143	M14x50 220		
Hexagon head screws Item 5 Tightening torque [Nm]	M5x20 8,5	M5x20 8,5	M6x25 14	M8x30 35	M8x30 35	M10x40 69		
Hexagon head screws Item 5 (Hub Type 95_1_) Tightening torque [Nm]	M5x45 8,5	M5x50 8,5	M6x60 14	M8x70 35	M8x80 35	M10x90 69		
Hexagon head screws Item 5 (Hub Type 95_5_) Tightening torque [Nm]	M5x18 8,5	M5x18 8,5	M6x22 14	M8x30 35	M8x30 35	M10x35 69		
Hexagon head screws Item 6 Tightening torque [Nm]	M5x32 8,5	M5x32 8,5	M6x40 14	M8x50 35	M8x50 35	M10x60 69		
Adjusting screws for hub Type 95_0_ _ with hub bore Tightening torque [Nm]	M5 ≤22 2	M6 >22 4,1	M5 ≤22 2	M6 >22 4,1	M6 4,1	M8 8,5	M10 14	M12 35
Adjusting screws for hub Type 95_1_ _ Tightening torque [Nm]	M8 8,5	M8 8,5	M10 14	M10 14	M12 35	M12 35		

Installation and Operational Instructions for ROBA[®]-DS couplings Type 95²/₃ (Disk Pack HT) Sizes 16 - 160 (B.9.7.2.GB)

**Table 2: Transmittable Torques on Shrink Disk Hubs, Large (1.8)
- dependent on the bore / valid for H7/g6**

Bore	Size					
	16	25	40	64	100	160
Ø25	339	-	-	-	-	-
Ø28	404	-	-	-	-	-
Ø30	448	-	-	-	-	-
Ø32	492	526	-	-	-	-
Ø35	558	602	-	-	-	-
Ø38	620	679	-	-	-	-
Ø40	659	730	873	-	-	-
Ø42	694	780	937	-	-	-
Ø45	738	851	1036	1268	-	-
Ø48	-	913	1132	1394	-	-
Ø50	-	948	1195	1480	-	-
Ø52	-	978	1255	1565	-	-
Ø55	-	-	1338	1691	2074	-
Ø60	-	-	1454	1890	2366	-
Ø65	-	-	-	2065	2658	3246
Ø70	-	-	-	2204	2943	3618
Ø75	-	-	-	-	3213	3991
Ø80	-	-	-	-	3458	4353
Ø85	-	-	-	-	3666	4695
Ø90	-	-	-	-	3828	5007
Ø100	-	-	-	-	-	5497

Danger!
Please observe the permitted coupling torques of the coupling size used.

**Table 3: Transmittable Torques on Shrink Disk Hubs (1.1/1.2)
- dependent on the bore / valid for H7/g6**

Bore	Size					
	16	25	40	64	100	160
Ø14	157	-	-	-	-	-
Ø16	179	-	-	-	-	-
Ø20	240	280	-	-	-	-
Ø22	269	308	-	-	-	-
Ø25	312	375	438	-	-	-
Ø28	-	428	491	-	-	-
Ø30	-	468	526	708	-	-
Ø32	-	509	600	756	-	-
Ø35	-	568	669	826	1090	-
Ø38	-	-	741	960	1184	-
Ø40	-	-	796	1031	1246	1794
Ø42	-	-	852	1104	1320	1884
Ø45	-	-	932	1206	1500	2019
Ø50	-	-	-	-	1692	2400
Ø55	-	-	-	-	1889	2680
Ø60	-	-	-	-	-	2967
Ø65	-	-	-	-	-	3263

Danger!
Please observe the permitted coupling torques of the coupling size used.

Installation and Operational Instructions for ROBA®-DS couplings Type 95²/₃ (Disk Pack HT) Sizes 16 - 160 (B.9.7.2.GB)

**Table 4: Transmittable Torques on Clamping Hubs (1.9)
- dependent on the bore / valid for H7/h6**

Bore	Size					
	16	25	40	64	100	160
Ø20	183	-	-	-	-	-
Ø22	202	354	-	-	-	-
Ø25	229	402	604	-	-	-
Ø28	257	450	677	821	-	-
Ø30	275	483	725	880	-	-
Ø32	293	515	773	938	1102	-
Ø35	321	563	846	1026	1205	-
Ø38	348	611	918	1114	1309	-
Ø40	367	643	967	1173	1378	1839
Ø42	385	676	1015	1232	1447	1931
Ø45	412	724	1087	1319	1550	2069
Ø48	-	772	1160	1407	1653	2207
Ø50	-	804	1208	1466	1722	2299
Ø52	-	836	1257	1525	1791	2391
Ø55	-	-	1329	1613	1894	2529
Ø60	-	-	1450	1759	2066	2759
Ø65	-	-	-	1906	2239	2989
Ø68	-	-	-	1994	2342	3127
Ø70	-	-	-	2053	2411	3219
Ø75	-	-	-	-	2583	3449
Ø80	-	-	-	-	2755	3679
Ø85	Danger! Please observe the permitted coupling torques of the coupling size used.		-	-	2927	3909
Ø90	-	-	-	-	3100	4139
Ø95	-	-	-	-	-	4369
Ø100	-	-	-	-	-	4599

Installation and Operational Instructions for ROBA®-DS couplings Type 95²/₃ (Disk Pack HT) Sizes 16 - 160

(B.9.7.2.GB)

Function – Application

ROBA®-DS couplings are shaft connections for torsionally rigid, backlash-free torque transmission. At the same time they compensate for angular misalignments and axial displacements on single-jointed couplings (Type 952. . . .), and additionally for radial misalignments on double-jointed couplings (Type 953. . . .).

State of Delivery

The ROBA®-DS couplings are delivered in individual parts and in pre-assembled assemblies.



All screw connections must be pre-tensioned during final installation to a torque according to Table 1.

Except for the disk pack (2), all parts are phosphated and therefore have a basic corrosion protection.

All hub designs can be delivered either pilot bored or finish bored.

The preferred bore tolerance is H7; deviating bores are possible (please contact the manufacturers).

The key hubs (Items 1 and 1.4) additionally have a keyway acc. DIN 6885 Pages 1 or 3, as well as an adjusting screw for axial securement.

Temperature Resistance

Due to their all-steel design, ROBA®-DS couplings are temperature-resistant up to +250 °C.

At temperatures of over +120 °C, the standard self-locking hexagon nuts must be replaced with self-locking all-steel nuts acc. EN ISO 7042.

Installation Position

ROBA®-DS couplings are designed for horizontal installation. In case of vertical or inclined installation, on long sleeves (sleeves S/CRD/CFRP) the sleeve's own weight must be supported with a vertical support (Fig. 3). This vertical support including both centerings in the hub and in the sleeve is produced at the place of manufacture.

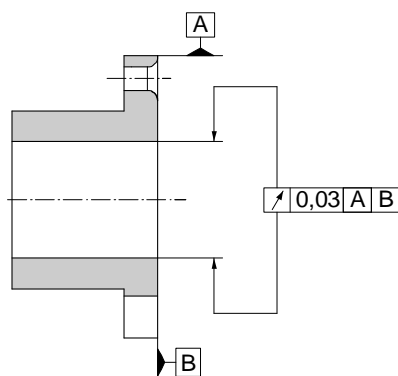

Fig. 2

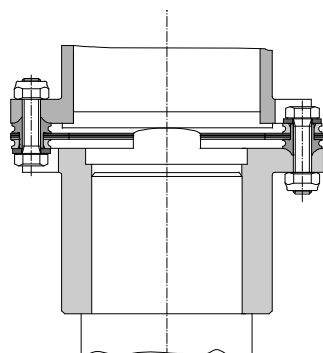

Fig. 3

Guidelines on Hub Bore and Shaft

General Guidelines:

- The maximum bore diameter according to Table 1 must not be exceeded.
- The preferred hub bore tolerance is H7. The required shaft tolerance is dependent on the hub type used, as well as on the basic overall load configuration.
 - Shrink disk hub/ Clamping hubs: h6/g6
 - Key hubs:
 - r6/s6 (alternating rotational direction),
 - k6/n6 (one-way rotational direction)
- The recommended bore tolerances are to be produced using the position and tolerance width as references; at the same time, please keep to the shaft run-out and axial run-out tolerances of 0,03 (see Fig. 2).
- After producing the finish bore, please clean it using suitable cleaning agents.
- The shaft surfaces should be finely turned or ground (Ra = 0,8 µm).
- The required yield point for the shafts used is at least 350 N/mm² (St60, St70, C45, C60).

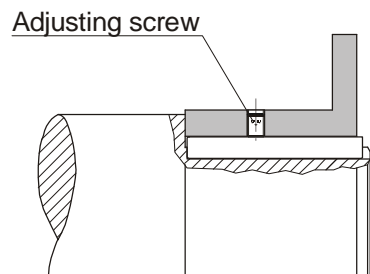

Fig. 4

Please observe the following when boring the hub with keyway (Items 1 and 1.4) Types 95_0_ . . . and 95_1_ . . . :

- The specified form (DIN 6885 Pages 1 or 3) and position* of the keyway.
 - * Position of the keyway on Type:
 - 95_0_ (Item 1) aligned with a fixing hole.
 - 95_1_ (Item 1.4) 25° offset to a fixing hole.
- For axial securement, please provide an additional adjusting screw (ISO 4029 - 45H) as an alternative to a press cover (see Figs. 4 and 5). The adjusting screw dimensions and tightening torques stated in Table 1 must be kept to.

Please observe the following when boring the shrink disk hubs (Items 1.1, 1.2 and 1.8) Types 95_2_ . . . , 95_3_ . . . and 95_9_ . . . :

- The shrink disk hubs are generally delivered greased and pre-assembled. For production of the finish bore, the shrink disk is de-installed and the hub is de-greased.
- De-burr the hubs, in particular in the area of the slots.
- Clean and re-grease the hubs in the shrink disk contact area. Permitted grease: Klüber Alltemp QNB 50

Hub Installation

The arrangement of the individual components is shown in Fig. 1.

Hub Installation Types 95²/₃ / 95³/₃ / 95⁹/₃ (Hubs with Shrink Disk)



- ❑ The force transmission of the shrink disk hubs (1.1/1.2/1.8) takes place using frictional locking. The contact surfaces between the shrink disk and the hub are greased manufacturer-side.
- ❑ The hub bores and the shaft ends must be completely grease-free during installation.
Greasy or oily bores or shafts do not transmit the maximum coupling torque.
- ❑ The shafts must not have a keyway.
- ❑ The hub and the shrink disk (1.1.2/1.8.2) must be completely relaxed. If necessary, loosen the screws (1.1.1/1.2.1/1.8.1) by several thread turns.

- a) Mount the hubs (1.1/1.2/1.8) onto the shafts using a suitable device and bring them into the correct position.
- b) Tighten the tensioning screws (1.1.1/1.2.1/1.8.1) evenly and **one after the other in several tightening sequences** using a torque wrench to the torque stated in Table 1.
- c) Check the tightening torques produced after 5 to 10 operating hours.

For De-installation:

- a) Loosen all tensioning screws (1.1.1/1.2.1/1.8.1) in several sequences by several thread turns.
- b) Screw out the tensioning screws located next to the tapped extracting holes and screw them into the tapped extracting holes up to their limits.



Please take the axial space requirements for the tensioning screws to be screwed into the tapped extracting holes into account (for length of the hexagon head screws Item 1.1.1 / Item 1.8.1, see Table, page 3).

- c) Tighten the tensioning screws (1.1.1/1.2.1/1.8.1) evenly and in steps so that the shrink disk (1.1.2/1.8.2) is loosened from the hub.

Hub Installation Type 95⁵/₃ (Clamping Hubs)



- ❑ The hub bores and the shaft ends must be completely grease-free during installation.
Greasy or oily bores or shafts do not transmit the maximum coupling torque.
- ❑ The shafts must not have a keyway.
- ❑ The clamping hub (1.9) must be completely relaxed; if necessary loosen the screws (1.9.1) by several thread turns.

- a) Mount the hubs (1.9) onto the shafts using a suitable device and bring them into the correct position.
- b) Tighten the clamping screws (1.9.1) using a torque wrench to the torque stated in Table 1.
- c) Check the tightening torques produced after 5 to 10 operating hours.

Hub Installation Types 95⁰/₃ / 95¹/₃ (Hubs with Keyway)

- ❑ Mount the hubs (1 / 1.4) onto the shafts using a suitable device and secure them axially (Fig. 5). Axial securement takes place using a set screw (adjusting screw), which presses radially onto the key; or via a press cover and a screw, screwed into the shaft threaded centre hole.
- ❑ The key must lie over the entire length of the hub.

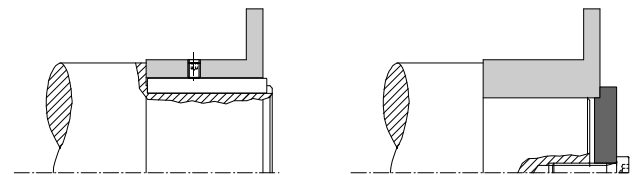

Fig. 5

Installation and Operational Instructions for ROBA®-DS couplings Type 95²/₃ (Disk Pack HT) Sizes 16 - 160 (B.9.7.2.GB)

Coupling Installation (Figs. 1 and 6)

The disk packs (2) are screwed together **alternately** with the sleeve (3) and the hubs or the connection plate (4) using lightly oiled hexagon head screws (5 and 6), washers (7) and hexagon nuts (8).

Whilst doing this, please produce the tightening torque acc. Table 1 in several steps.

The hexagon nuts (8) or the hexagon head screws (5 and 6) must be tightened step by step to their full tightening torque acc. Table 1. Please see Table 5 for the respective tightening torques for each step.

Table 5

Step	Tightening torques for hexagon nuts (8) or hexagon head screws (5 and 6)
1	30 % of the nominal torque
2	60 % of the nominal torque
3	100 % of the nominal torque

The disk pack (2) must not under any circumstances be distorted when applying the pre-tension force.



The disk pack (2) is always to be inserted so that the collar bushing radius (part 2a, Fig. 6, detail "X") lies in the hub grooves, the sleeve grooves or the connection plate grooves.



Due to the enlarged diameter of the shrink disks (1.8.2), please make sure that the installation sequence is suitable. In this way, normal torque wrenches can be used for installation of the disk pack (2).

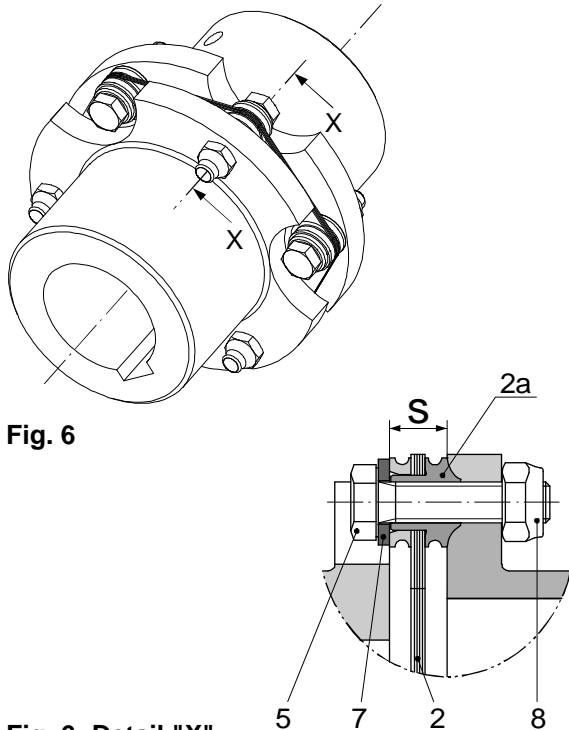

Fig. 6

Fig. 6: Detail "X"

Coupling Alignment

Exact coupling alignment reduces the reaction forces and therefore increases the lifetime of the coupling and the shaft bearing.

In most of the applications, coupling alignment using a straight edge in two levels vertical to each other is sufficient. However, we recommend alignment of the coupling using a dial gauge or laser on drives operating at very high speeds. In order to prevent axial distortion of the disk packs, dimension "S" (Fig. 6, detail "X", Table 1) must be maintained with aligned angular and radial misalignments.

Permitted Shaft Misalignments

ROBA®-DS single-jointed couplings (Type 952.____) compensate for angular and axial shaft misalignments; ROBA®-DS double-jointed couplings (Type 953.____) compensate for angular, axial and radial shaft misalignments (Fig. 8) without losing their backlash-free function. However, the permitted shaft misalignments indicated in the Table 1 must not simultaneously reach their maximum value. If more than one kind of misalignment takes place simultaneously, they influence each other. This means that the permitted misalignment values are dependent on one another, see Fig. 7. The sum total of the actual misalignments in percent of the maximum value must not exceed 100 % (see Example and Fig. 7).

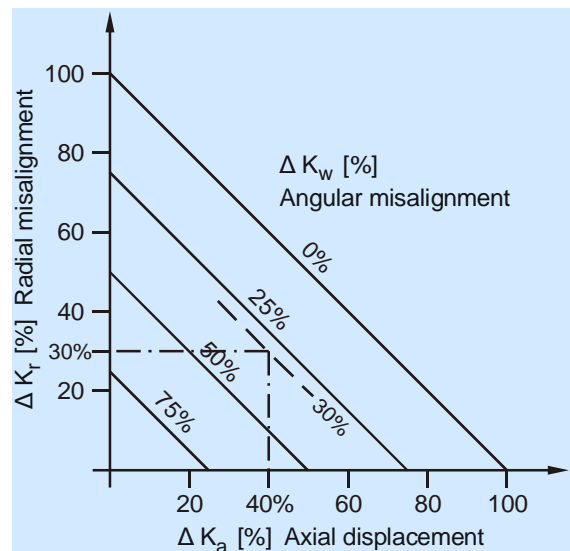
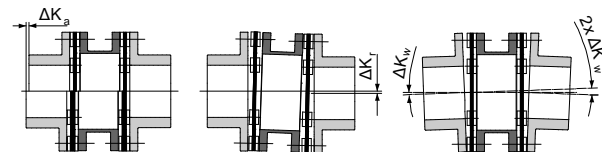

Fig. 7

Example:

ROBA®-DS, Size 40, Type 953.002
Axial displacement occurrence $\Delta K_a = 0,44$ mm equals 40 % of the permitted maximum value $\Delta K_a = 1,1$ mm
Angular misalignment occurrence in the disk pack $\Delta K_w = 0,21^\circ$ equals 30 % of the permitted maximum value $\Delta K_w = 0,7^\circ$
=> Permitted radial misalignment $\Delta K_r = 30$ % of maximum value $\Delta K_r = 1,0$ mm => $\Delta K_r = 0,3$ mm



Axial displacement Radial misalignment Angular misalignment

Fig. 8

Installation and Operational Instructions for ROBA®-DS couplings Type 95²/₃ (Disk Pack HT) Sizes 16 - 160

(B.9.7.2.GB)

Balancing the Coupling

In most applications, balancing the ROBA®-DS coupling is not necessary. The following points are generally crucial when deciding whether the coupling needs balancing:

- Circumferential speed of the coupling
- Length of the sleeves S/CRD/CFRP (Diagram 1)
- Required balance quality

Diagram 1: Balancing Coupling with Sleeves S/CRD/CFRP (Special Length)

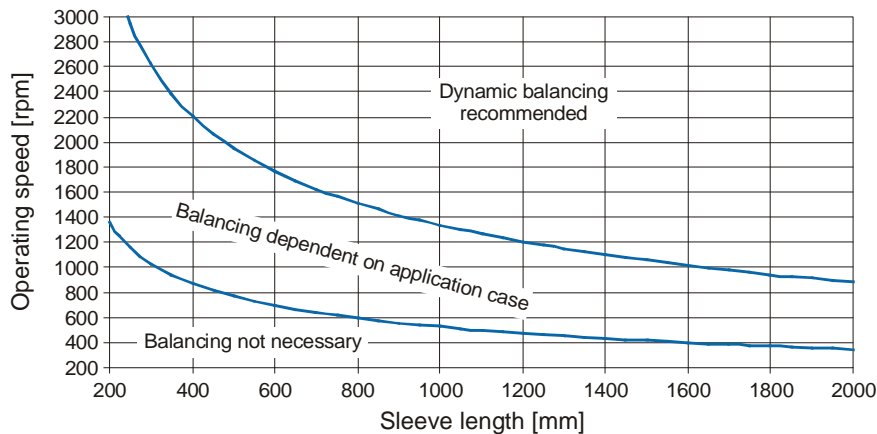

Smooth running of the machine is not only ensured by the coupling balance quality, but is also influenced by parameters such as stiffness and distance to the adjacent bearings as well as by the sensitivity and mass of the entire construction.

Diagram 1, therefore, only shows reference values for which balancing is recommended.

All parts of the ROBA®-DS couplings, except the sleeves S/CRD/CFRP, are machined on all sides, and therefore lie in the range G 6,3 acc. DIN ISO 1940 at medium speeds (1500 rpm).

If higher demands are placed on the balance quality, it is possible to balance individual parts or even the entire installed coupling (on request). For this, however, the hubs must be in finish bore design.

Diagram 2: Permitted Speeds (Bend-critical) for Sleeves S Type 953. . . 3 and Sleeves CRD Type 953. . . 4 (only Size 160)

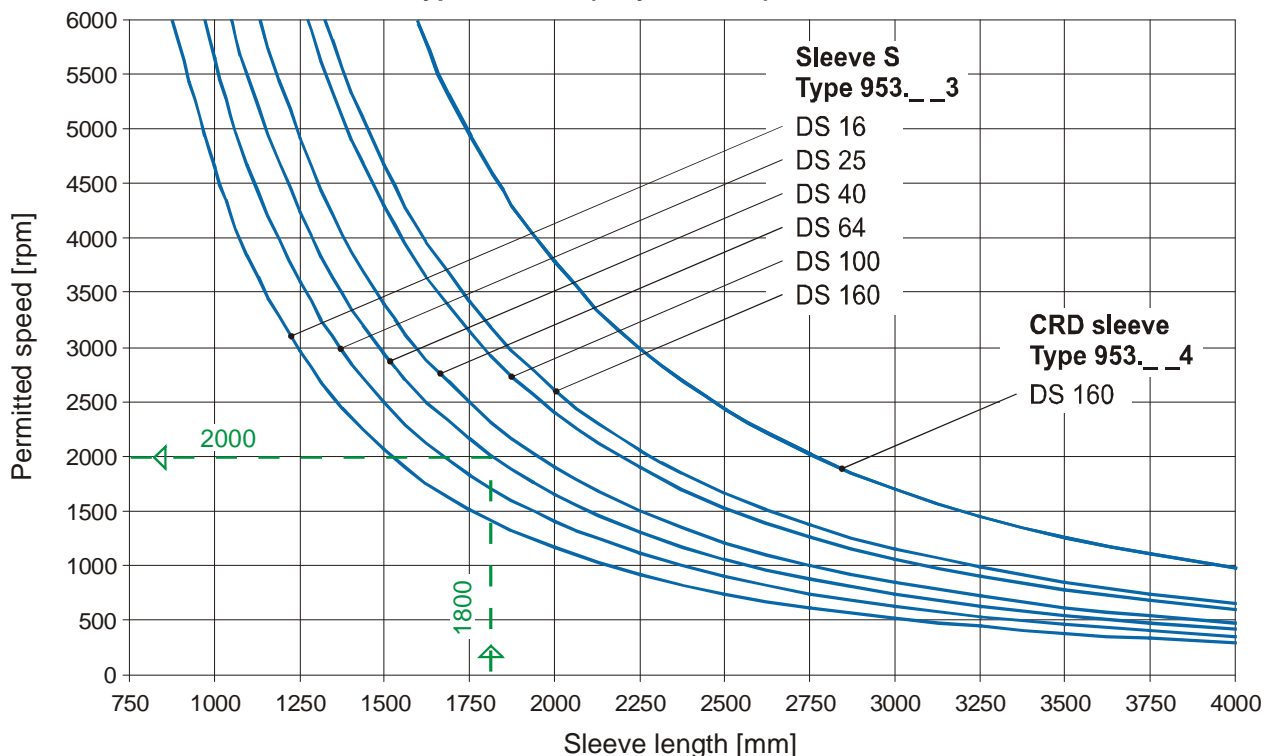

Example:

Size 40, sleeve length $H_s = 1800$ mm => permitted speed 2000 rpm.

Diagram 3: Permitted Speeds (Bend-critical) for Sleeves CFRP Type 953. . . 5

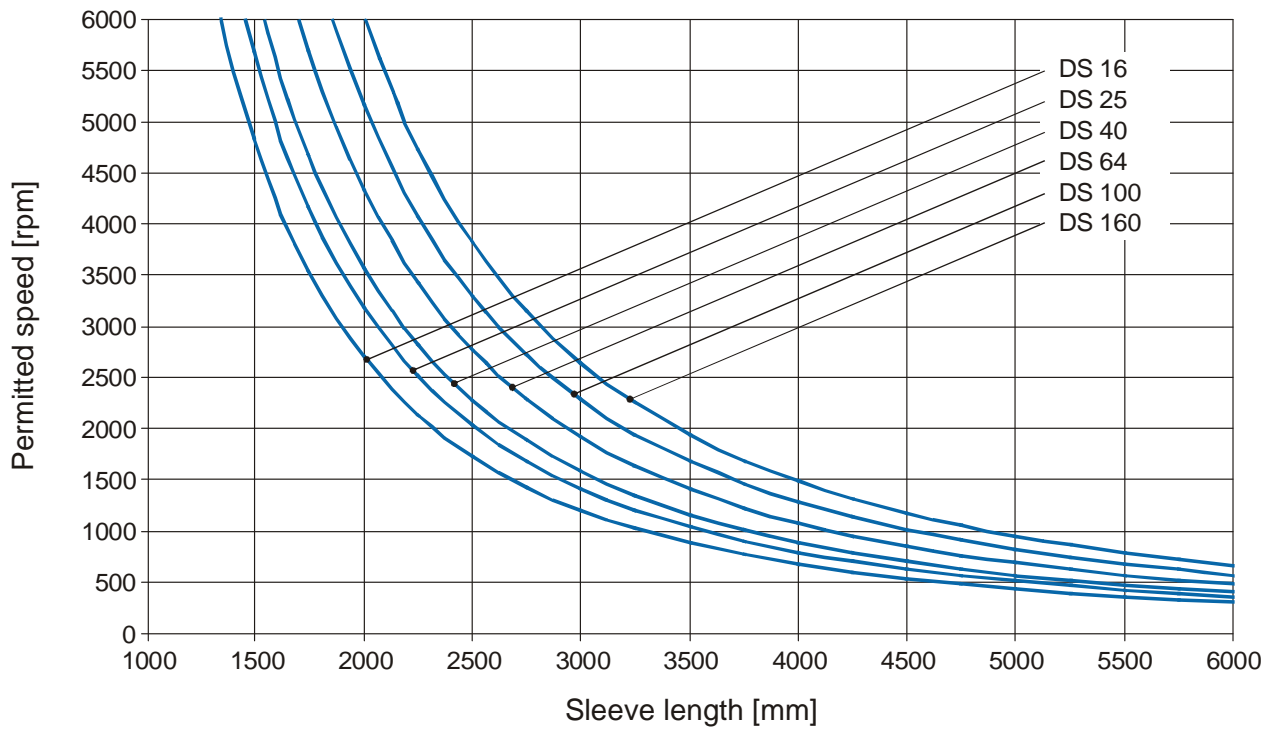

Installation and Operational Instructions for ROBA[®]-DS couplings Type 95²/₃ (Disk Pack HT) Sizes 16 - 160 (B.9.7.2.GB)

Maintenance

ROBA[®]-DS couplings are mainly maintenance-free.

The following maintenance and inspection intervals are to be maintained:

- 1.) Visual inspection, installation parameter inspections (misalignment and tightening torques), coupling running behaviour **before initial start-up.**
- 2.) Visual inspection, torsional backlash, inspection of the misalignment and the tightening torques, coupling running behaviour **after 1000h, at the latest after 3 months.**
- 3.) If no irregularities or wear are found during the second maintenance and inspection interval, further inspection intervals can, with unchanged operating parameters, take place **after 4000 operating hours or after maximum 12 months.**

In extreme coupling ambient or operating conditions, the maintenance and inspection intervals should be shortened.

Disposal

All steel components and carbon pipes:
Steel scrap (Code No. 160117)

Malfunctions / Breakdowns

Malfunction	Possible Causes	Solutions
Changes in running noise and / or vibration occurrence	Incorrect alignment, incorrect installation	<ol style="list-style-type: none"> 1) Set the system out of operation 2) Find and remove the cause of incorrect alignment 3) Check the coupling for wear
	Loose connecting screws, minor friction corrosion under the screw head and on the disk pack	<ol style="list-style-type: none"> 1) Set the system out of operation 2) Check the coupling parts and replace if damaged 3) Tighten the connecting screws to the specified torque 4) Check the alignment and correct if necessary
	Tensioning and clamping screws or locking set screw for axial hub securement are loose	<ol style="list-style-type: none"> 1) Set the system out of operation 2) Check the coupling alignment 3) Tighten the tensioning and clamping screws for axial hub securement to the required torque or tighten the locking set screw and secure it against self-loosening using sealing lacquer 4) Check the coupling for wear
Disk pack breakage	Disk pack breakage due to high load impacts / overload	<ol style="list-style-type: none"> 1) Set the system out of operation 2) Dismantle the coupling and remove the remainders of the disk packs 3) Check the coupling parts and replace if damaged 4) Find the cause of overload and remove it
	Operating parameters are not appropriate for the coupling performance	<ol style="list-style-type: none"> 1) Set the system out of operation 2) Check the operating parameters and select a suitable coupling (observe installation space) 3) Install a new coupling 4) Check the alignment
	Incorrect operation of the system unit	<ol style="list-style-type: none"> 1) Set the system out of operation 2) Dismantle the coupling and remove the remainders of the disk packs 3) Check the coupling parts and replace if damaged 4) Train and advise operating personnel
Disk pack / connecting screw cracks or breakage	Drive vibrations	<ol style="list-style-type: none"> 1) Set the system out of operation 2) Dismantle the coupling and remove the remainders of the disk packs 3) Check the coupling parts and replace if damaged 4) Check the alignment and correct if necessary 5) Find the cause of vibration and remove it



mayr[®] will take no responsibility or guarantee for replacement parts and accessories which have not been delivered by mayr[®], or for damage resulting from the use of these products.