

Please read these Operational Instructions carefully and follow them accordingly!

Ignoring these Instructions may lead to malfunctions or to coupling failure, resulting in damage to other parts.

Contents:

- Page 1:** - Contents
- Safety Regulations
- Safety and Guideline Signs
- Page 2:** - Summary of Constructional Designs
- Page 3:** - Parts List
- Page 4:** - Table 1: Technical Data
- Page 5:** - Table 2: Transmittable Torques on Clamping Hubs
- Page 6:** - Table 3: Transmittable Torques on Split Clamping Hubs
- Transmittable Torques on Shrink Disk Hubs
- Page 7:** - Function - Application
- State of Delivery
- Temperature Resistance
- Guidelines on Hub Bore and Shaft
- Installation Position
- Page 8:** - Hub Installation
- Page 9:** - Coupling Installation
- Page 10:** - Coupling Alignment
- Permitted Shaft Misalignments
- Page 11:** - Balancing the Coupling
- Diagram 1: Balancing the Couplings with Sleeve
- Page 12:** - Diagram 2: Permitted Speeds for Sleeve S
- Maintenance
- Disposal
- Page 13:** - Malfunctions / Breakdowns

Safety and Guideline Signs

CAUTION



Danger of injury to personnel and damage to machines.



Please Observe!
Guidelines on important points.



According to German notation, decimal points in this document are represented with a comma (e.g. 0,5 instead of 0.5).

Safety Regulations

These Installation and Operational Instructions (I + O) are part of the coupling delivery. Please keep them handy and near to the coupling at all times.



It is forbidden to start initial operation of the product until you have ensured that all applicable EU directives and directives for the machine or system, into which the product has been installed, have been fulfilled. At the time these Installation and Operational Instructions go to print, the ROBA[®]-DS couplings accord with the known technical specifications and are operationally safe at the time of delivery. Without a conformity evaluation, this product is not suitable for use in areas where there is a high danger of explosion. This statement is based on the ATEX directive.

DANGER



- If the ROBA[®]-DS couplings are modified.
- The relevant standards for safety and / or installation conditions are ignored.

User-implemented Protective Measures

- Cover all moving parts to protect against seizure, dust or foreign body impact.

To prevent injury or damage, only professionals and specialists should work on the devices, following the relevant standards and directives. Please read the Installation and Operational Instructions carefully prior to installation and initial operation of the device.

These Safety Regulations are user hints only and may not be complete!

Installation and Operational Instructions for ROBA®-DS couplings Type 95⁰₁. --- Sizes 3 to 15

(B.9.7.1.EN)

Summary of Constructional Designs

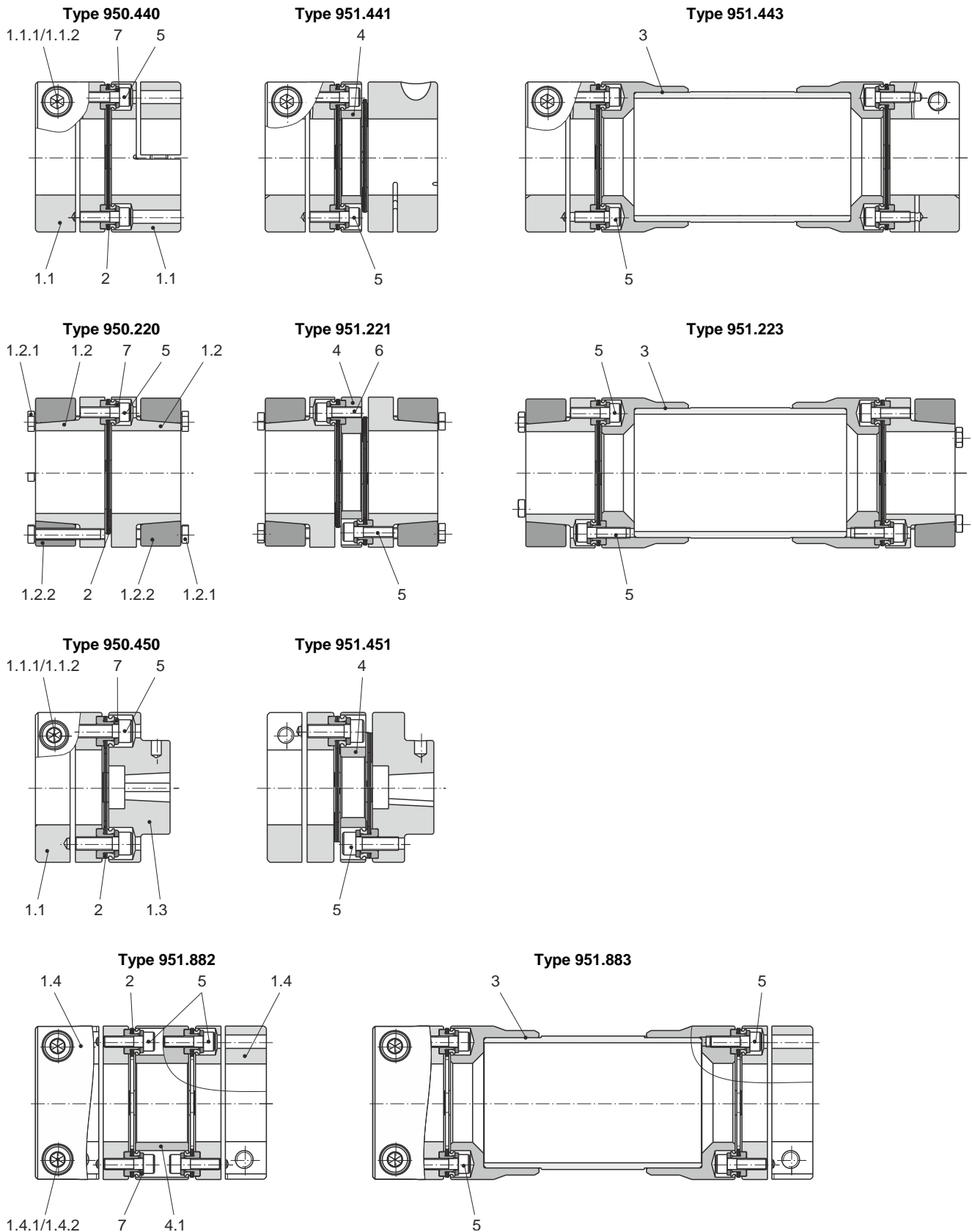

Fig. 1

Installation and Operational Instructions for ROBA[®]-DS couplings Type 95⁰₁. --- Sizes 3 to 15

(B.9.7.1.EN)

Parts List

Only use *mayr*[®] original parts

Item	Name
1.1	Clamping hub Type 95_4_ _
1.1.1	Cap screw for clamping hub Type 95_4_ _
1.1.2	Washer
1.2	Shrink disk hub Type 95_3_ _
1.2.1	Hexagon head screws for shrink disk hub Type 95_3_ _
1.2.2	Shrink disk
1.3	Hub with tapered bore Type 95_5_ _
1.4	Split clamping hub Type 95_8_ _
1.4.1	Cap screw for split clamping hub Type 95_8_ _
1.4.2	Washer
2	Disk pack
3	Sleeve
4	Connection plate
4.1	Connection plate HSK
5	Cap screw
6	Cap screw
7	Washer

Installation and Operational Instructions for ROBA[®]-DS couplings Type 95⁰₁. --- Sizes 3 to 15

(B.9.7.1.EN)

Table 1: Technical Data

ROBA [®] -DS Size		3		6			10	15
$d_{R\ min}$ Hub Type 95_4_ (Item 1.1)	[mm]	10		14			19	25
$d_{R\ max}$ Hub Type 95_4_ (Item 1.1)	[mm]	20		28			35	42
$d_{S\ min}$ Hub Type 95_2_ (Item 1.2)	[mm]	10		14			19	25
$d_{S\ max}$ Hub Type 95_2_ (Item 1.2)	[mm]	20		28			38	45
$d_F \pm 0,05$ Hub Type 95_5_ (Item 1.3)	[mm]	11	14	11	14	16	---	---
$d_{H\ min}$ Hub Type 95_8_ (Item 1.4)	[mm]	10		14			19	25
$d_{H\ max}$ Hub Type 95_8_ (Item 1.4)	[mm]	20		28			35	42
Coupling nominal torque T_{KN} Valid for max. permitted shaft misalignment	[Nm]	35		60			100	150
Coupling alternating torque T_{KW} Valid for max. permitted shaft misalignment	[Nm]	21		36			60	90
Coupling peak torque T_{KS} Valid for unchanging load direction, max. load cycles $\leq 10^5$	[Nm]	52		90			150	225
Max. speed n_{max} on Type 95_2_ (not valid for sleeve)	[rpm]	22500		18000			15000	13000
Max. speed n_{max} on Type 95_4_ (not valid for sleeve)	[rpm]	13500		10800			9000	7800
Max. speed n_{max} on Type 95_5_ (not valid for sleeve)	[rpm]	22500		18000			15000	13000
Max. speed n_{max} on Type 95_8_ (not valid for sleeve)	[rpm]	3000		3000			3000	3000
Distance dimension "S" (Fig. 4 / page 9)	[mm]	2,5 \pm 0,2		2,6 \pm 0,2			2,9 \pm 0,2	2,9 \pm 0,25
Axial displacement ΔK_a Values refer to couplings with 2 disk packs. Only permitted as a static or virtually static value.	[mm]	\pm 0,5		\pm 0,7			\pm 0,9	\pm 1,1
Radial misalignment ΔK_r , for Type 951_1	[mm]	0,15		0,15			0,2	0,2
Radial misalignment ΔK_r , for Type 951_3	[mm]	$(H_S - S) \times 0,0174$						
Radial misalignment ΔK_r , for Type 951.882	[mm]	0,35		0,4			0,45	0,5
Radial misalignment for single-jointed coupling		If there is only one disk pack, the shafts must be aligned exactly.						
Angular misalignment ΔK_w per disk pack	[°]	1		1			1	1
Cap screw Item 1.1.1 (Hub Type 95_4_) Tightening torque	[Nm]	M6 x 20 14		M6 x 20 13			M8 x 25 33	M8 x 30 33
Hexagon head screw Item 1.2.1 (Hub Type 95_2_) Tightening torque	[Nm]	M4 x 22 3		M5 x 25 6			M5 x 25 6	M5 x 35 6
Hexagon head screw Item 1.4.1 (Hub Type 95_8_) Tightening torque	[Nm]	M6 x 20 14		M6 x 20 13			M8 x 25 33	M8 x 30 33
Cap screws Item 5 Tightening torque	[Nm]	M4 x 14 4,5		M5 x 16 8,5			M5 x 18 8,5	M5 x 20 8,5
Cap screws Item 6 Tightening torque	[Nm]	M4 x 12 4,5		M5 x 16 8,5			M5 x 16 8,5	M5 x 16 8,5

Installation and Operational Instructions for ROBA[®]-DS couplings Type 95⁰₁. --- Sizes 3 to 15

(B.9.7.1.EN)

Table 2:
Transmittable Torques on Clamping Hubs (1.1) - Dependent on Bore - Suitable for H7/k6

Bore	Size			
	3	6	10	15
Ø10	27	-	-	-
Ø12	32	-	-	-
Ø14	37	46	-	-
Ø15	39	51	-	-
Ø16	42	56	-	-
Ø18	47	65	-	-
Ø19	49	70	99	-
Ø20	52	74	105	-
Ø22	-	84	116	-
Ø24	-	92	128	-
Ø25	-	95	135	143
Ø28	-	107	151	163
Ø30	-	-	162	177
Ø32	-	-	173	191
Ø35	Attention! Please observe permitted peak torques for selected coupling size and Type.		189	211
Ø38	-	-	-	229
Ø40	-	-	-	241
Ø42	-	-	-	253



The transmittable torques refer to a temperature range from -20 °C up to +40 °C.
At temperatures over +40 °C, the frictionally-locking transmittable torque reduces by 10 % per 10 °C.
The max. permitted operating temperature is +80 °C.

Installation and Operational Instructions for ROBA[®]-DS couplings Type 95₁⁰ Sizes 3 to 15

(B.9.7.1.EN)

Table 3:
Transmittable Torques on Split Clamping Hubs (1.4) - Dependent on Bore - Suitable for H7/g6

Bore	Size			
	3	6	10	15
Ø10	31	-	-	-
Ø12	38	-	-	-
Ø14	44	44	-	-
Ø15	47	47	-	-
Ø16	50	50	-	-
Ø18	57	57	-	-
Ø19	60	60	115	-
Ø20	63	63	121	-
Ø22	-	69	133	-
Ø24	-	75	145	-
Ø25	-	79	151	151
Ø28	-	99	169	169
Ø30	-	-	181	181
Ø32	-	-	193	193
Ø35	Attention! Please observe permitted peak torques for selected coupling size and Type.		211	211
Ø38	-	-	-	230
Ø40	-	-	-	242
Ø42	-	-	-	254



The transmittable torques refer to a temperature range from -20 °C up to +40 °C.
At temperatures over +40 °C, the frictionally-locking transmittable torque reduces by 10 % per 10 °C.
The max. permitted operating temperature is +80 °C.

Transmittable Torques on Shrink Disk Hubs

The transmittable torques on shrink disk hubs Type 95₂ equal the maximum coupling torques.



Exception:
On Size 3 and a preferred bore Ø 10, the max. transmittable torque is: 41 Nm

Installation and Operational Instructions for ROBA®-DS couplings Type 95₁⁰. --- Sizes 3 to 15

(B.9.7.1.EN)

Function – Application

ROBA®-DS couplings are shaft connections for torsionally rigid, backlash-free torque transmission. At the same time they compensate for angular misalignments and axial displacements on single-jointed couplings (Type 950.____), and additionally for radial misalignments on double-jointed couplings (Type 951.____).

State of Delivery

ROBA®-DS couplings are delivered completely manufacturer-assembled.

In special cases, the ROBA®-DS couplings are delivered in individual parts and pre-assembled units.



All screw connections must be checked or pre-tensioned during the final installation to a torque value according to Table 1.

Hubs and sleeves are made of aluminium, the disks are made of stainless steel.

The shrink disks (1.2.2) as steel components are phosphated and therefore have a basic corrosion protection. The rest of the connection elements are oiled.

Temperature Resistance

Temperature resistance of ROBA®-DS Sizes 3 to 15:
from -20 °C up to +100 °C.

The clamping ring hub torques transmitted via frictional locking, however, depend on bores and temperatures. (Please observe the guidelines below Table 2).

Guidelines on Hub Bore and Shaft

General Guidelines:

- ❑ The maximum bore diameter according to Table 1 may not be exceeded.
- ❑ For application with clamping hubs (1.1), a tolerance connection of H7/k6 should be selected. For application with split clamping hubs (1.4), a tolerance connection of H7/g6 should be selected.
The shrink disk hubs (1.2) should have a tolerance connection of H7/g6 on bores smaller than Ø 25 H7/h6.
- ❑ On clamping hubs (1.1) and split clamping hubs (1.4) the transmittable torques are dependent on the bore and must be observed acc. Table 2 or 3. The Tables do not take temperatures over +40 °C into account. Please observe the guidelines below Tables 2 and 3.
- ❑ On shrink disk hubs (1.2), the transmittable torques on the shaft-hub connection exceed the maximum coupling values, and are therefore not additionally specified.
The only exception to this is the shrink disk hub (1.2) Size 3 with bore Ø 10. In this case, only max. 41 Nm can be transmitted.
These values are valid for the entire permitted temperature range from -20 °C up to +100 °C.
- ❑ The recommended bore tolerances are to be produced using the position and tolerance width as references; at the same time, please keep to the shaft run-out and axial run-out tolerances of 0,03 mm (see Fig. 2).
- ❑ The shaft surfaces should be finely turned or ground (Ra = 0,8 µm).
- ❑ The required yield point for the shafts used is at least 350 N/mm² (St60, St70, C45, C60).

Please observe the following when boring the shrink disk and radial clamping hubs (Items 1.1, 1.2):

- ❑ The shrink disk hubs (1.2) are generally delivered greased and pre-assembled. For production of the finish bore, the shrink disk (1.2.2) is de-installed and the shrink disk hub (1.2) is de-greased.
- ❑ Deburr the hubs (1.1 / 1.2), in particular in the area of the slots.
- ❑ Clean and re-grease the shrink disk hubs (1.2) in the contact area of the shrink disk or hub.
Permitted grease: Klüber Alltemp QNB 50

Installation Position

ROBA®-DS couplings are designed for horizontal installation. In case of vertical or inclined installation, on long sleeves (3) the sleeve's own weight must be supported with a vertical support. This vertical support including both centerings in the hub and in the sleeve is produced at the place of manufacture.

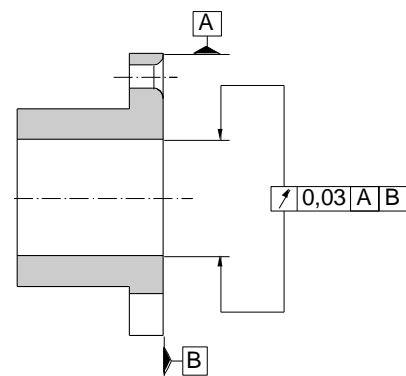

Fig. 2

Hub Installation

The configuration of the different individual components can be seen in Fig. 1.

Guidelines on the Hub Installation of Types 95₂ (Shrink Disk Hubs) or 95₄ (Clamping Hubs):



- ❑ The torque transmission of the clamping hubs (1.1) or the shrink disk hubs (1.2) takes place using frictional locking.
- ❑ The contact surfaces between the shrink disk (1.2.2) and the hub (1.2) are greased manufacturer-side.
- ❑ The hub bores and the shaft ends must be completely grease-free during installation. Greasy or oily bores or shafts do not transmit the maximum coupling torque.
- ❑ The shafts must not have a keyway.
- ❑ The clamping hubs (1.1) or the shrink disk hubs (1.2) must be completely relaxed. If necessary, loosen the screws (1.1.1 or 1.2.1) by several thread turns.

Hub Installation Type 95₂ (Shrink Disk Hubs)

- a) Mount the shrink disk hubs (1.2) onto the shafts using a suitable device and bring them into the correct position.
- b) Tighten the tensioning screws (1.2.1) using a torque wrench evenly and **one after the other in 3 to max. 6 tightening sequences** to the torque stated in Table 1.
- c) Check the tightening torque produced after 5 to 10 operating hours.

For De-installation:

- a) Loosen all tensioning screws (1.2.1) in several sequences by several thread turns.
- b) Normally the hubs on the shaft are loosened by hand. If this is not possible, please proceed as follows: Remove the tensioning screws (1.2.1) and screw them into the tapped extracting holes in-between. Then, tighten them evenly and one after the other until the shrink disk (1.2.2) loosens.



Please take the axial space requirements for the tensioning screws to be screwed into the tapped extracting holes into account (length of the hexagon head screws Item 1.2.1 in Table 1).

Hub Installation Type 95₄ (Clamping Hubs)

- a) Mount the clamping hubs (1.1) onto the shafts using a suitable device and bring them into the correct position.



The clamping screw (1.1.1) must be greased **in the area of the thread**. This is usually carried out manufacturer-side. For greasing, please use NLGI Class 1,5 grease with a basic oil viscosity of 460 mm²/s at 40 °C, e.g. Mobilith SHC460. Should the grease layer be washed off, it must be re-greased customer-side.

- b) Tighten the clamping screw (1.1.1) using a torque wrench to the torque stated in Table 1.
- c) Check the tightening torque produced after 5 to 10 operating hours.

Hub Installation Type 951.8 (Split Clamping Hubs)

- a) Loosen the pre-assembled half-shells from the hubs (1.7), **making sure that their correlation to the hub is maintained.**



The cap screws (1.4.1) must be greased **in the area of the thread**. This is usually carried out manufacturer-side. For greasing, please use NLGI Class 1,5 grease with a basic oil viscosity of 460 mm²/s at 40 °C, e.g. Mobilith SHC460. Should the grease layer be washed off, it must be re-greased customer-side.

- b) Place the coupling from above onto the shafts and pre-assemble it with the respective half-shells.
- c) Tighten the cap screws (1.4.1) using a torque wrench to the torque stated in Table 1.
- d) Tighten the cap screws (1.4.1) alternately and in several tightening sequences to the tightening torque stated in Table 1. Please make sure that the gap "X" (Fig. 3) has the same size on both hub sides. If necessary, re-adjust it.
- e) Check the tightening torque produced after 5 to 10 operating hours.

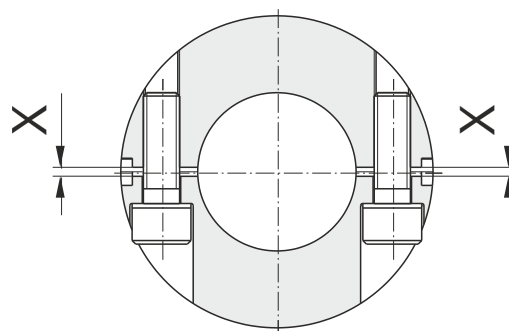

Fig. 3

Installation and Operational Instructions for ROBA®-DS couplings Type 95⁰₁. --- Sizes 3 to 15

(B.9.7.1.EN)

Coupling Installation (Figs. 1 and 4)

The disk packs (2) are screwed together **alternately** with the hubs and the sleeve (3) or the connection plate (4) using lightly oiled cap screws (5 and 6) with washers (7).

Here, the tightening torque acc. Table 1 must be produced in several steps.

The cap screws (5 and 6) must be tightened in several steps to their full tightening torque acc. Table 1. Please see Table 4 for the respective tightening torques for each step.



In order to install the shrink disk hubs (1.2) with the respective connection elements, the shrink disk (1.2.2) must be unscrewed from the shrink disk hub (1.2).

Table 4

Step	Tightening torque of the cap screws (Items 5 and 6)
1	30 % of the nominal tightening torque
2	60 % of the nominal tightening torque
3	100 % of the nominal tightening torque

The disk pack (2) must not under any circumstances be distorted when applying the pre-tension force.



The disk pack (2) is to be installed in such a way that the collar bushing (**Item 2a, Fig. 4**) is combined with the corresponding tolerance bore in the respective hub, connection plate (4) or in the sleeve (3).

Due to the high joining forces (caused by the transition tolerance) installation of the disk packs is only possible using the screw pre-tension force.

For disk pack (2) disassembly, use suitable tools, e.g. screwdrivers on the right and left side of the collar bushing (Fig. 5).

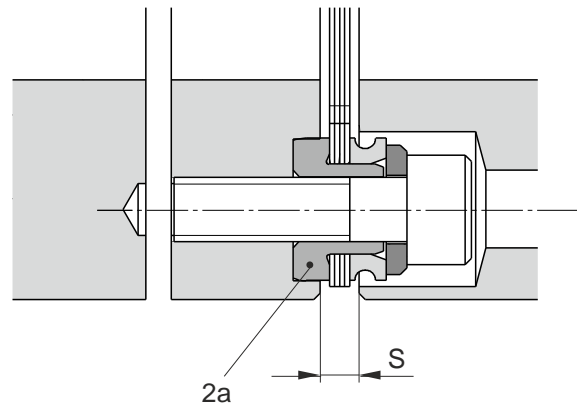

Fig. 4



Fig. 5

Coupling Alignment

Exact coupling alignment reduces the reaction forces and therefore increases the lifetime of the coupling and the shaft bearing.

In most of the applications, coupling alignment using a straight edge in two levels vertical to each other is sufficient.

However, we recommend alignment of the coupling (of the shaft ends) using a dial gauge or laser on drives operating at very high speeds.

In order to prevent axial distortion of the disk packs, the dimension "S" (see Fig. 4 / page 9 and Table 1) must be maintained with aligned angular and radial shaft misalignments.

Permitted Shaft Misalignments

ROBA®-DS single-jointed couplings (Type 950.---) compensate for angular and axial shaft misalignments. ROBA®-DS double-jointed couplings (Type 951.---) compensate for angular, axial and radial shaft misalignments (Fig. 7) without losing their backlash-free function. However, the permitted shaft misalignments indicated in Table 1 must not simultaneously reach their maximum value. If more than one kind of misalignment takes place simultaneously, they influence each other. This means that the permitted misalignment values are dependent on one another, see Fig. 6. The sum total of the actual misalignments in percent of the maximum value must not exceed 100 % (see example and Fig. 6).

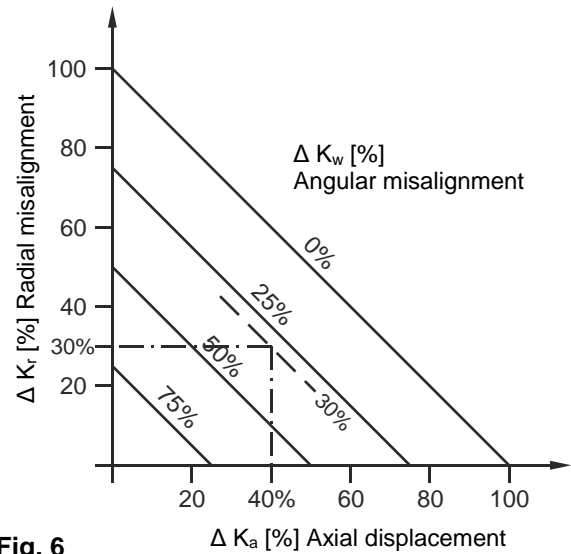

Fig. 6

Example:

ROBA®-DS, Size 10, Type 951.221

Axial displacement occurrence $\Delta K_a = 0,36$ mm equals 40 % of the permitted maximum value $\Delta K_a = 0,9$ mm

Angular misalignment occurrence in the disk pack $\Delta K_w = 0,3^\circ$ equals 30 % of the permitted maximum value $\Delta K_w = 1^\circ$

=> permitted radial misalignment $\Delta K_r = 30$ % of the maximum value $\Delta K_r = 0,2$ mm => $\Delta K_r = 0,06$ mm

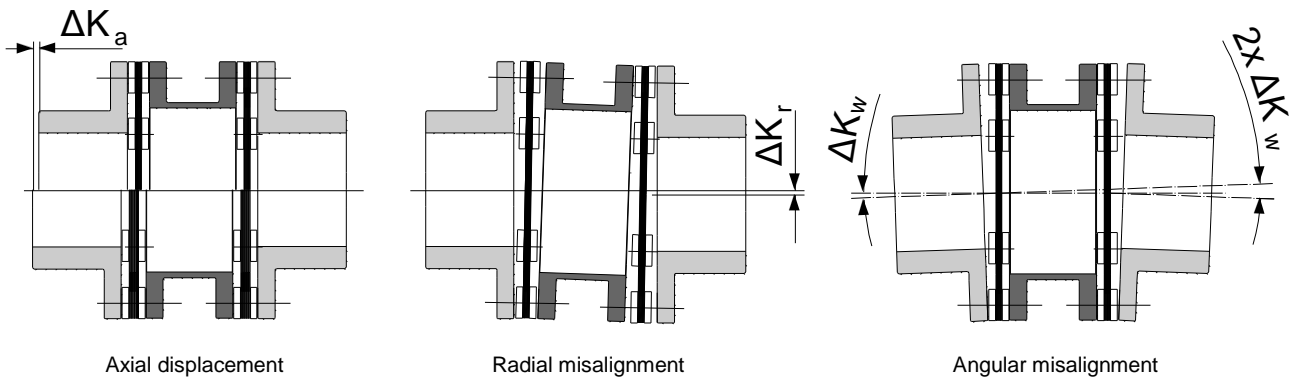

Fig. 7

Balancing the Coupling

In most applications, balancing the ROBA[®]-DS coupling is not necessary.

In general, the following points are crucial when deciding whether the coupling needs balancing:

- Circumferential speed of the coupling
- Length of the sleeves S (Diagram 1)
- Required balance quality

Diagram 1: Balancing the Couplings with Sleeve S (Special Length)

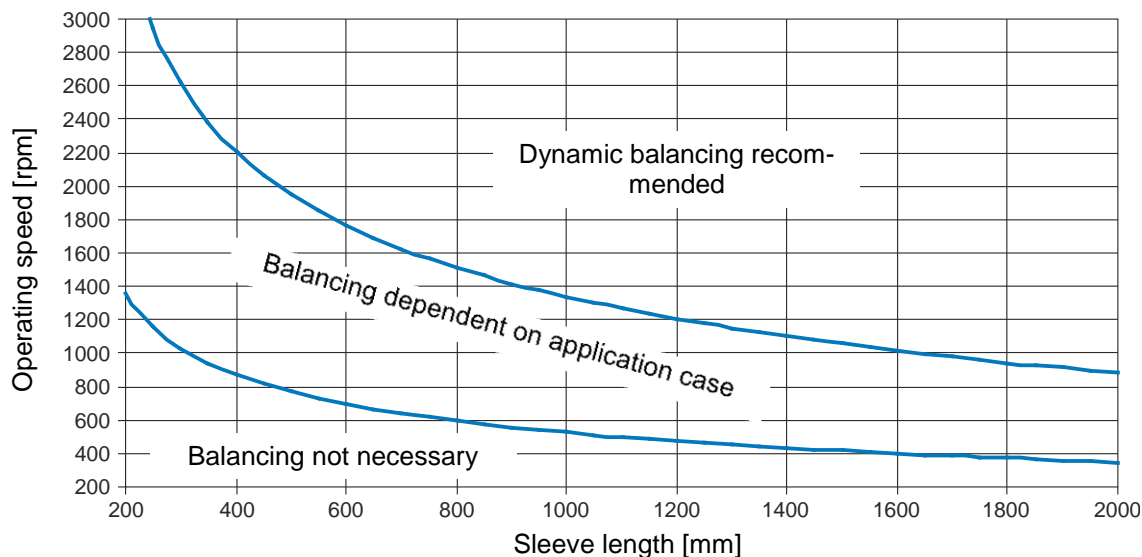

Smooth running of the machine is not only ensured by the coupling balance quality, but is also influenced by parameters such as rigidity and distance to the adjacent bearings as well as by the sensitivity and mass of the entire construction.

Diagram 1, therefore, only shows reference values as recommendations for balancing.

All parts of the ROBA[®]-DS couplings, except for the sleeve S pipe, are machined on all sides, and therefore lie in the range G 6,3 acc. ISO DIN 1940 at medium speeds (1500 rpm).

When ordering the coupling with a special sleeve, please always state the coupling operating speed.

If higher demands are placed on the balance quality, it is possible to balance individual parts or even the entire installed coupling (on request). However, for this option, the hubs must have a finish bore.

Diagram 2: Permitted Speeds (Bend-critical) for Sleeves S Type 951._ _3

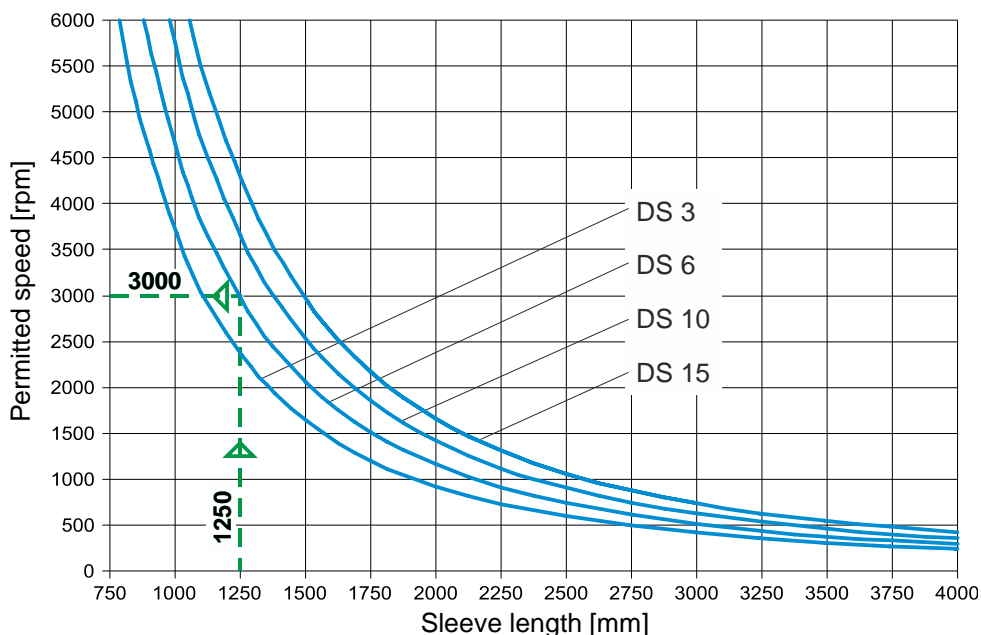

Example:

Size 10, sleeve length $H_s = 1250$ mm => permitted speed 3000 rpm.



The coupling must be operated in the subcritical speed range.
Attention: When passing through the bend-critical speed (resonance), there is a danger of coupling destruction.

Maintenance

ROBA®-DS couplings are mainly maintenance-free.

The following maintenance and inspection intervals are to be maintained:

- 1.) Visual inspection, inspection of the installation parameters (misalignment and tightening torques) and the coupling running behaviour **before initial operation.**
- 2.) Visual inspection, torsional backlash, inspection of the misalignment and the tightening torques, coupling running behaviour **after 1000 h, at the latest after 3 months.**
- 3.) If no irregularities or wear are found during the second maintenance and inspection interval, further inspection intervals can, with unchanged operating parameters, take place **after 4000 operating hours or after maximum 12 months.**

In extreme coupling ambient or operating conditions, the maintenance and inspection intervals should be shortened.

Disposal

All steel components:

Steel scrap (Code No. 160117)

All aluminium components:

Non-ferrous metals (Code No. 160118)

Installation and Operational Instructions for ROBA®-DS couplings Type 95⁰₁ Sizes 3 to 15

(B.9.7.1.EN)

Malfunctions / Breakdowns

Malfunction	Possible Causes	Solutions
Changes in running noise and / or vibration occurrence	Incorrect alignment, incorrect installation	<ol style="list-style-type: none"> 1) Set the system out of operation 2) Find / resolve the cause of incorrect alignment 3) Check the coupling for wear
	Loose connecting screws, fretting corrosion under the screw head and on the disk pack	<ol style="list-style-type: none"> 1) Set the system out of operation 2) Check the coupling parts and replace if damaged 3) Tighten the connecting screws to the specified torque 4) Check the alignment and correct if necessary
	Tensioning and clamping screws for axial securement of the hubs are loose	<ol style="list-style-type: none"> 1) Set the system out of operation 2) Check the coupling alignment 3) Tighten the tensioning and clamping screws for axial hub securement to the required torque and secure it against self-loosening using sealing lacquer 4) Check the coupling for wear
Disk pack breakage	Disk pack breakage due to high load impacts / overload	<ol style="list-style-type: none"> 1) Set the system out of operation 2) Dismantle the coupling and remove the remainders of the disk packs 3) Check the coupling parts and replace if damaged 4) Find the cause of overload and remove it
	Operating parameters are not appropriate for the coupling performance	<ol style="list-style-type: none"> 1) Set the system out of operation 2) Check the operating parameters and select a suitable coupling (observe installation space) 3) Install a new coupling 4) Check the alignment
	Incorrect operation of the system unit	<ol style="list-style-type: none"> 1) Set the system out of operation 2) Dismantle the coupling and remove the remainders of the disk packs 3) Check the coupling parts and replace if damaged 4) Train and advise operating personnel
Disk packs / connecting screws cracks or breakage	Drive vibrations	<ol style="list-style-type: none"> 1) Set the system out of operation 2) Dismantle the coupling and remove the remainders of the disk packs 3) Check the coupling parts and replace if damaged 4) Check the alignment and correct if necessary 5) Find the cause of vibration and remove it



mayr® will take no responsibility or guarantee for replacement parts and accessories which have not been delivered by mayr®, or for damage resulting from the use of these products.