

Please read and observe this Operating Instruction carefully!
A possible malfunction or failure of the brake and any damage may be caused by not observing it.

Table of contents:

- Page 1:** - Table of contents
- Declaration of conformity
- Safety regulations
- Page 2:** - View of the axial-element
- Parts list
- Page 3:** - Product description
- Design
- Function
- Supply condition
- Application examples (Figs. 2 and 3)
- Page 4:** - Table 1: Dimensions and tightening torques
- Table 2: Disengaging forces and maximum free strokes
- Page 5:** - Table 3: Length layout with given free stroke: in tensile direction H_1 / in compressive direction H_2
- Page 6:** - Assembly
- Adjustment of the disengaging force
- Adjustment of the limit switch
- Wiring example
- Maintenance
- Disposal
- Page 7:** - Adjusting diagrams sizes 1-3
- Page 8:** - Adjusting diagrams sizes 4-6

Declaration of Conformity

A conformity evaluation for the applicable EU directives has been carried out for this product. The conformity evaluation is set out in writing in a separate document and can be requested if required. It is forbidden to start use of the product until the machine or system into which it should be built is operating in accordance with all applicable EU directives. Without a conformity evaluation, this product is not suitable for use in areas where there is a high danger of explosion. This statement is based on the ATEX directive.

Safety regulations

The submitted installation and operating instructions (I+O) is part of the clutch shipment. Keep the I+O always well accessible near the clutch.



Danger!

- If the EAS[®]-axial has been modified or reconverted.
- If the relevant standards of the safety or installation conditions are not observed.

Necessary protective measures to be undertaken by the user

- Cover all moving parts for protection against squeezing, seizing, dust deposit and hit of foreign objects.

Only qualified and well-trained specialists should work on the units to avoid any personal injury or damage to machinery under observance of the valid standards and guidelines. The installation and operating instructions are to be read carefully before installation and operation.

With these safety notes no claim on completeness is raised!

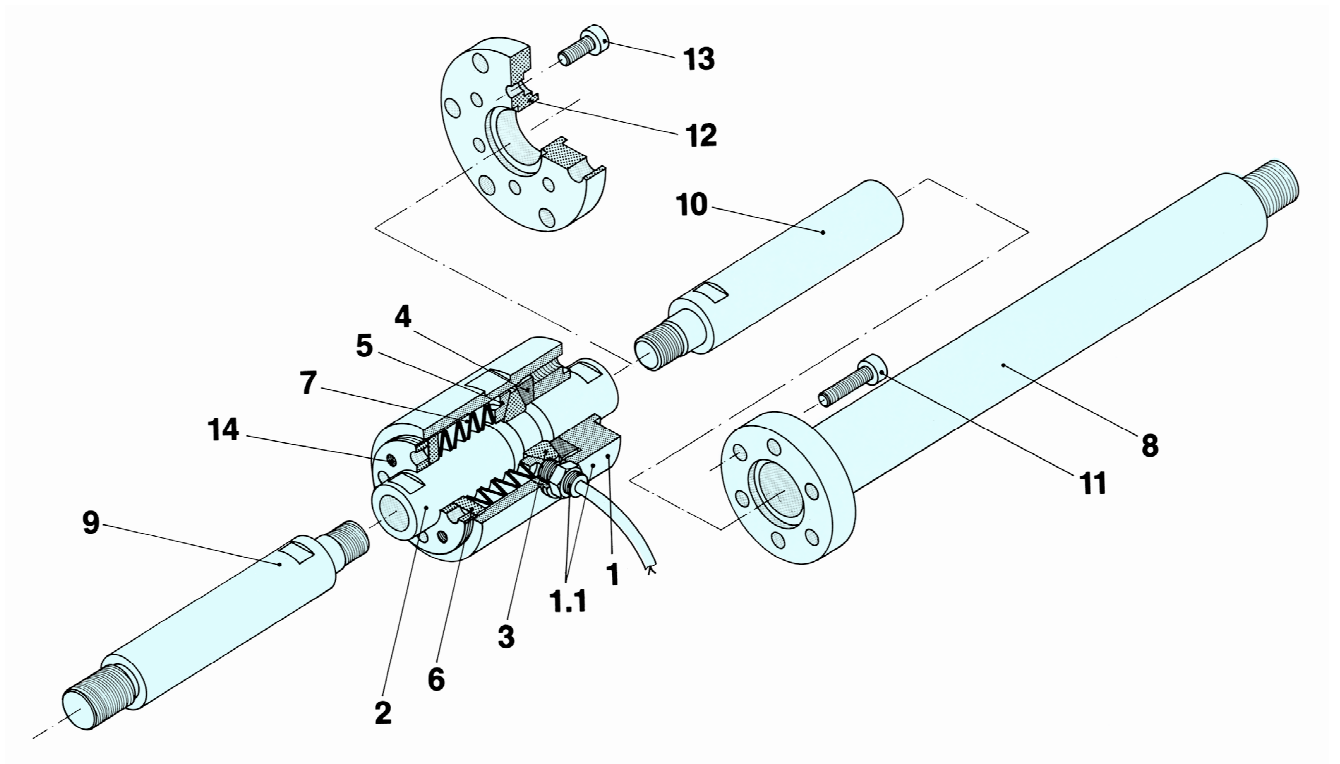

Fig. 1

Parts List (Only mayr[®]-original parts are to be used)

- | | | | |
|-----|---|----|--|
| 1 | Housing | 9 | Connecting rod (type dependent option) |
| 1.1 | Housing with integrated proximity switch
(type dependent option) | 10 | Guide rod (type dependent option) |
| 2 | Bolts | 11 | Cap screw |
| 3 | Switching segment | 12 | Exterior flange (type dependent option) |
| 4 | Thrust disc 1 | 13 | Cap screw |
| 5 | Thrust disc 2 | 14 | Set screw (only with sizes 1 – 4) |
| 6 | Adjusting nut | 15 | Set screw
(only with sizes 5 – 8 / illustr. page 6, Fig. 5) |
| 7 | Cup spring | 16 | Hexagon nut
(only with sizes 5 – 8 / illustr. page 6, Fig. 5) |
| 8 | Sleeve (type dependent option) | | |

Product description

The EAS[®]-axial is a safety element for force control for linear motion systems.

The EAS[®]-axial is available with or without integrated proximity switch for recognition of the overload.

Application ranges are:

- Protection in cam actuated machinery.
- Torque arm for shaft mounted gear reducers.
- Linear motion application.

Design

The EAS[®]-axial limits compressive forces, tensile forces or tensile and compressive forces depending on the design. **During disengagement the axial displacement of the element may not exceed the determined free stroke, as otherwise the element is pressed together until contact or extended. The max. permissible free strokes can be calculated using the Table 3 (length layout).**

Function

If there is a jam in the equipment (overload) the preset disengaging force is exceeded and the EAS[®]-axial disengages. The bolt (2) moves, the switching segments (3) are pressed outwards. The rigid connection between element and bolt (2) is abolished.

A residual force of 15 – 25 % of the set value remains after disengagement.

Re-engagement is made automatically during restarting by withdrawing or pushing back the bolt (2) to the original position.

Supply condition

The EAS[®]-axial is supplied without adjustment ready to be installed. On request the element is adjusted to the required disengaging force at the factory. The level of the disengaging force is indicated on the Type tag.

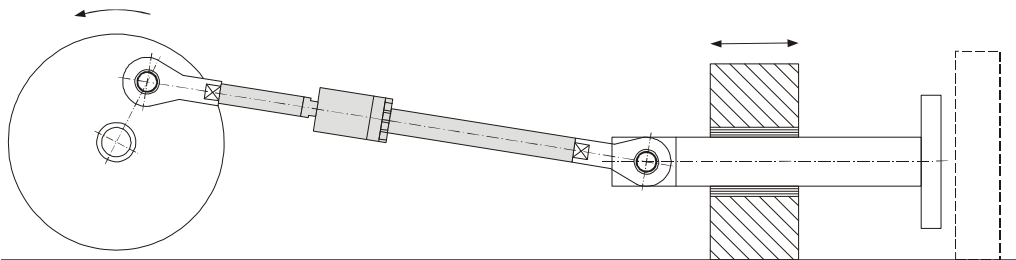

Fig. 2
Connected rod design for limiting tensile and compressive forces.

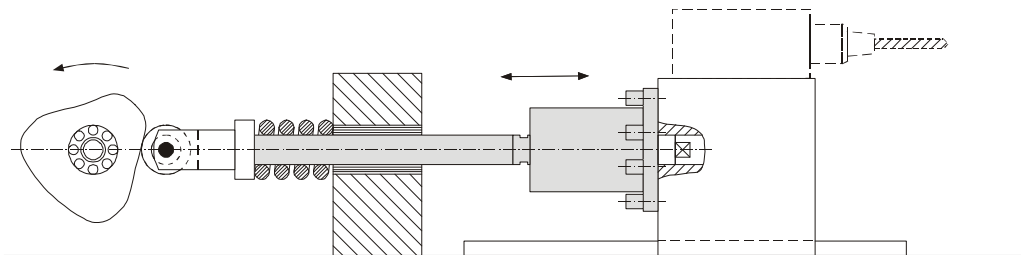

Fig. 3:
Exterior flanged version for limiting compressive forces.

Table 1: Dimensions and tightening torques

Size	Dimensions [mm] Illustration in the catalogue K.403.C								Tightening torques [Nm]			
	A ₁	a	a ₁	c	G	G ₁	l	z	Connecting rod Pos. 9	Guide rod Pos. 10	Cap screw Pos. 11	Cap screw Pos. 13
1	8	8	6	5	M 8	M 6 x 0,75	38	2	2,5	2,5	0,7	0,7
2	10	12	10	6	M12	M10 x 0,75	53	2	8,0	8,0	3,3	3,3
3	12	15	10	8	M16	M12 x 1,0	70	3	24	24	5,6	5,6
4	15	20	15	10	M24 x 2	M20 x 1,0	95	4	90	90	13	13
5	21	32,5	15	12,5	M30 x 2	M24 x 1,5	142,5	6	260	260	20	20
6	30	35	15	16	M36 x 3	M30 x 1,5	180	8	650	650	51	51
7	40	50	25	20	M52 x 3	M48 x 2,0	275	10	-	-	140	140
8	55	65	30	26	M64 x 4	M75 x 2,0	365	15	-	-	420	420

Table 2: Disengaging forces and maximum free strokes

Size	Disengaging force F _A [N]			Maximum free strokes H _{1 max.} , H _{2 max.} [mm]
	Type 3 _ _ .4 _ _	Type 3 _ _ .5 _ _	Type 3 _ _ .6 _ _	
1	75 – 200	200 – 500	300 – 800	max. 200
2	200 – 500	500 – 800	800 – 2000	max. 300
3	300 – 600	600 – 2000	2000 – 5000	max. 400
4	600 – 2000	2000 – 6000	6000 – 12000	max. 500
5	3000 – 7500	6000 – 12000	12000 – 30000	max. 600
6	6000 – 12000	12000 – 30000	30000 – 70000	max. 700
7	12000 – 30000	30000 – 70000	70000 – 150000	max. 800
8	30000 – 70000	70000 – 150000	150000 – 300000	max. 1000

Installation and Operating Instructions for EAS[®]-axial Type 3 _ _ . _ _ _ Sizes 1 – 8

(B.3.1.GB)

Table 3: Length layout with indicated free stroke: in tensile direction H₁ / in compressive direction H₂

Disengaging direction free stroke		Design			Type	Minimum length of the connecting rod	Minimum length of the guide rod	Minimum length of the sleeve	Minimum overall length
Tension H ₁	Compression H ₂	Connecting rod	Element	Guide rod/ Sleeve		L ₁ [mm]	L ₂ [mm]	L ₃ [mm]	L ₄ [mm] *
					310._ _ 0			L ₃ = H ₂ +a +c +2	L ₄ = L ₃ +a ₁ +l
⊕ →					301._ _ 0	L ₁ = H ₂ -a ₁			L ₄ = L ₁ +a ₁ +l
⊕ →					321._ _ 0	L ₁ = H ₂ -a ₁			L ₄ = L ₁ +a ₁ +l +A ₁ -z
⊕ →					311._ _ 0	L ₁ = H ₂ -a ₁		L ₃ = H ₂ +a +c +2	L ₄ = L ₁ +L ₃ +a ₁ +l
← ⊕					302._ _ 0		L ₂ = H ₁ -a -2		L ₄ = a ₁ +l
← ⊕					322._ _ 0		L ₂ = H ₁ -a -2		L ₄ = a ₁ +l +A ₁ -z
← ⊕					312._ _ 0		L ₂ = H ₁ -a -2	L ₃ = H ₁ +c	L ₄ = L ₃ +a ₁ +l
← ⊕ →					303._ _ 0	L ₁ = H ₂ -a ₁	L ₂ = H ₁ -a -2		L ₄ = L ₁ +a ₁ +l
← ⊕ →					323._ _ 0	L ₁ = H ₂ -a ₁	L ₂ = H ₁ -a -2		L ₄ = L ₁ +a ₁ +l +A ₁ -z
← ⊕ →					313._ _ 0	L ₁ = H ₂ -a ₁	L ₂ = H ₁ -a -2	L ₃ = H ₁ +H ₂ +c	L ₄ = L ₁ +L ₃ +a ₁ +l

H₁ [mm] Free stroke in tensile direction
The max. defined free stroke in tensile direction must not be exceeded, as otherwise the element is uncompressed.

H₂ [mm] Free stroke in compressive direction.

* If a larger overall length is required, the sleeve or connecting rod must be correspondingly longer.

Dim. A₁, a, a₁, c, l and z from dimensions (Table 1).

L₁ [mm] Minimum length of the connecting rod to be able to accommodate the free stroke in compressive direction H₂.

L₂ [mm] Minimum length of the guide rod to be able to accommodate the free stroke in tensile direction H₁.

L₃ [mm] Minimum sleeve length.

L₄ [mm] Minimum overall length.

Installation and Operating Instructions for EAS[®]-axial Type 3 _ _ . _ _ _ Sizes 1 – 8

(B.3.1.GB)

Assembly

The EAS[®]-axial is supplied assembled and ready to be installed. There are special areas milled for the wrenches on the single parts to screw together the connecting rod (9), the guide rod (10) and the bolt (2). Loctite 243 is used on the screwed connections. The threads on the end of the connecting rod (9) and the sleeve (8) are manufactured for attaching spherical joints according to DIN 648, which are supplied from *mayr*[®] on request.

When the integral limit switch is used, the initiator cable must be attached in such a way that it can't be damaged due to the movement of the EAS[®]-axial during operation and during disengagement.

Adjustment of the disengaging force

The force at which the EAS[®]-axial shall disengage (disengaging force) is set by changing the cup spring pretension (7). Adjustment of the correct disengaging force means adjustment of the correct dimension "a" (Figs. 4 and 5). The adjusting diagrams on the pages 7 and 8 show the connection between the dimension "a" and the disengaging force. Please observe that there may be deviations to the values given in the diagram due to tolerances of the structural components. On request the EAS[®]-axial can be supplied pre-set to the required disengaging force.

Adjustment of the sizes 1 – 4:

After having released the set screws (14), the adjusting nut (6) is set to the dimension "a" requested in the setting diagram (pages 7 and 8) by the aid of a face wrench. The disengaging force is increased by clockwise rotation and reduced by counter clockwise rotation (direction of view to the front face of the adjusting nut (6)). Afterwards the adjusting nut (6) must be secured again by the aid of the set screws (14).

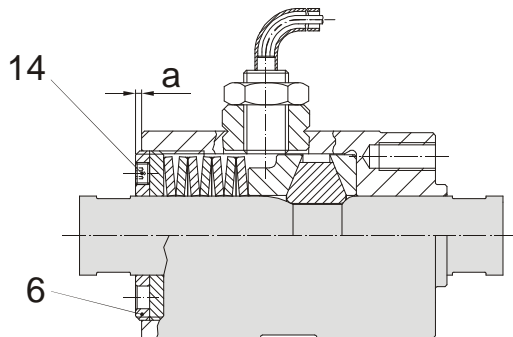

Fig. 4 (sizes 1 – 4)

Adjustment of the sizes 5 - 8:

There are 4 or 6 set screws (15) in the adjusting nut (6), which are adjusted to the dimension "a" (Fig. 5). Locking the set screws (15) with hexagon nuts (16) prevents any self-acting changing of the adjustment.

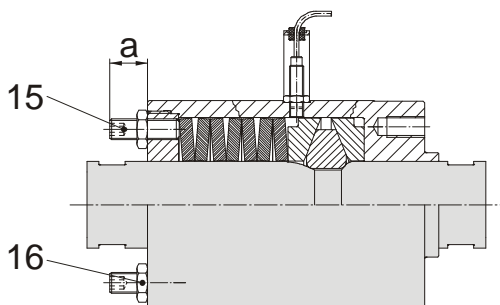

Fig. 5 (sizes 5 – 8)

Setting the limit switch (PNP-opener)

The EAS[®]-axial with integral limit switch provides a signal on disengagement (overload), which can be used to shut down the drive. The limit switch is installed at the factory.

Installing and adjusting:

Screw the initiator into the housing until it is damped. Move it slowly backwards until the switching condition changes (undamped). Continue turning approx. 45° (90° with size 1) and mark this setting. Lock initiator with a hexagon nut M8 x 1 (size 1: M5 x 0,5) carefully (tightening torque M5 = 1 Nm; M8 = 6 Nm). During locking you have to remove the backlash of threads in any case. The thread of the initiator must not be damaged.

After setting the initiator cable must be attached to the EAS[®]-axial in such a way that it cannot be damaged during operation (a strain relief is to be attached).

Wiring example:

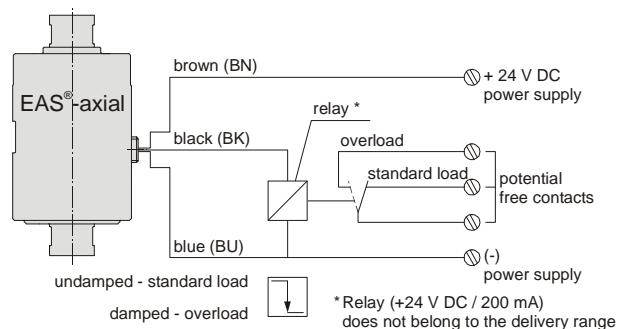

Fig. 6

Maintenance

The EAS[®]-axial is completely sealed, provided with a first grease-packing and therefore nearly maintenance-free. Special maintenance may only become necessary where there is a considerable amount of dust and dirt. The maintenance work at the EAS[®]-axial limits to the relubrication of the contact geometries. A grease of the NLGI class 2 with a viscosity class of 220 mm²/s with 40 °C, e. g. Mobil grease HP222, is suitable for the lubrication. The correct disengaging behaviour of the EAS[®]-axial should be checked annually.

We recommend to let the maintenance work be done at the factory.

Disposal

Electronic components

(Limit switch):

The undismantled products can be brought to the material utilization according to Code No. 160214 (mixed materials) or components to the disposal according to Code No. 160216 or disposed by a certified disposal company.

All steel components:

scrap (Code No. 160117)

Seals, O-rings, V-Seal, Elastomers:

plastic (Code No. 160119)

Installation and Operating Instructions for EAS[®]-axial Type 3 _ _ . _ _ _ Sizes 1 – 8

(B.3.1.GB)

Adjusting diagrams EAS[®]-axial, sizes 1 to 4

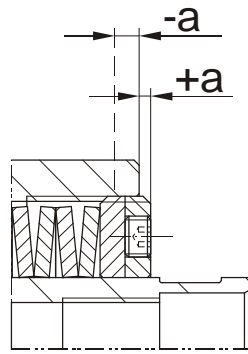
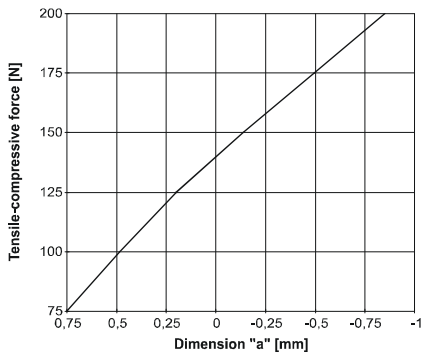
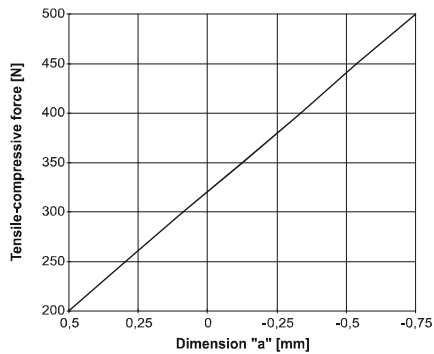

Fig. 7



Size 1, Type 3 _ .4 _



Size 1, Type 3 _ .5 _

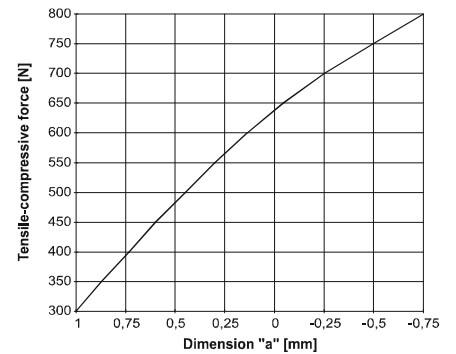

Size 1, Type 3 _ .6 _

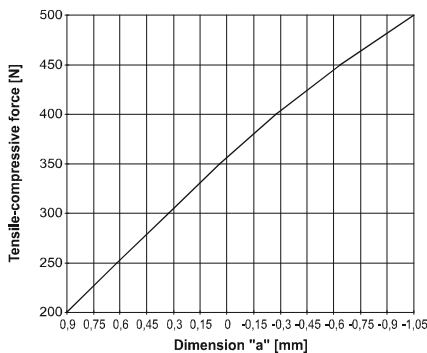

Size 2, Type 3 _ .4 _

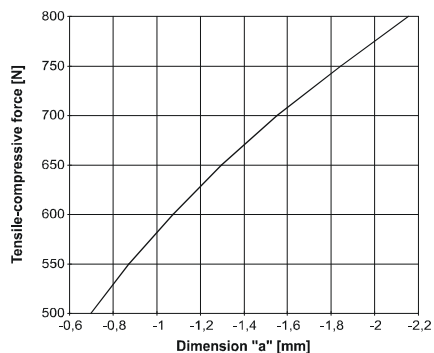

Size 2, Type 3 _ .5 _

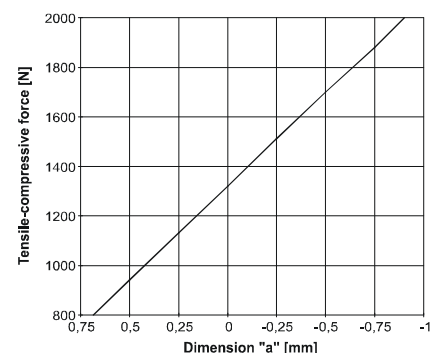

Size 2, Type 3 _ .6 _

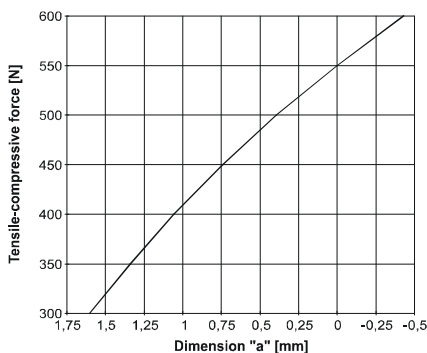

Size 3, Type 3 _ .4 _

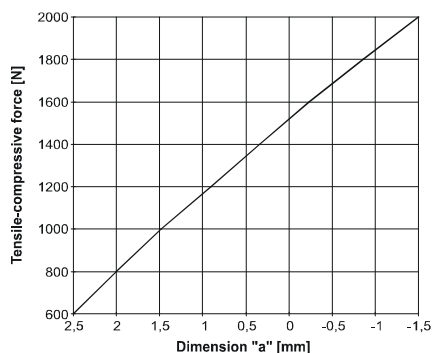

Size 3, Type 3 _ .5 _

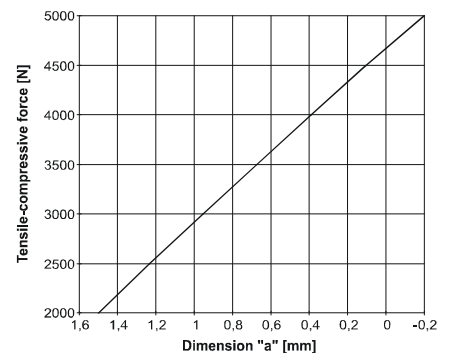

Size 3, Type 3 _ .6 _

Installation and Operating Instructions for EAS[®]-axial Type 3 _ _ . _ _ _ Sizes 1 – 8

(B.3.1.GB)

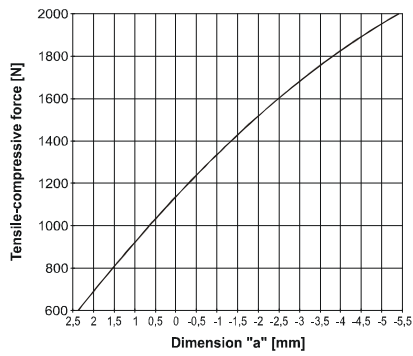

Size 4, Type 3 _ _ .4 _ _

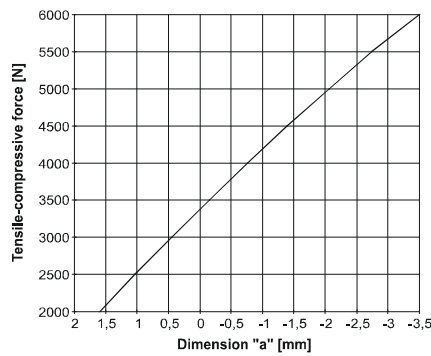

Size 4, Type 3 _ _ .5 _ _

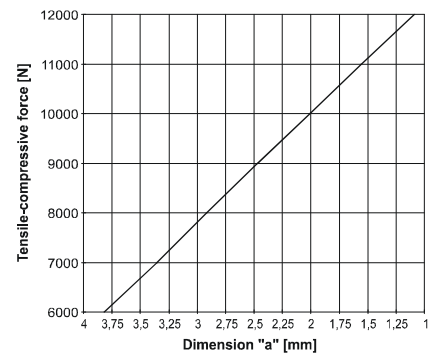

Size 4, Type 3 _ _ .6 _ _

Adjusting diagrams EAS[®]-axial, sizes 5 and 6

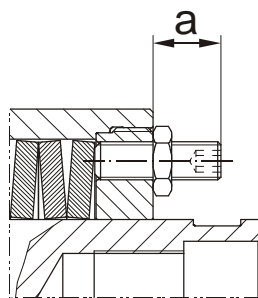
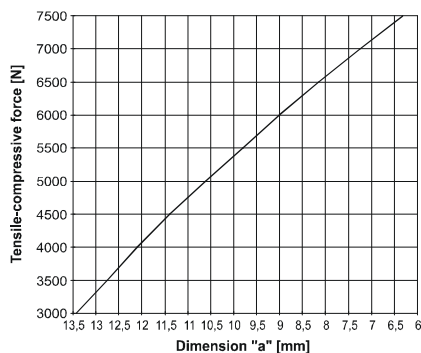
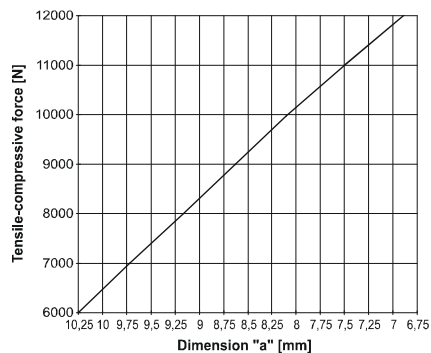

Fig. 8



Size 5, Type 3 _ _ .4 _ _



Size 5, Type 3 _ _ .5 _ _

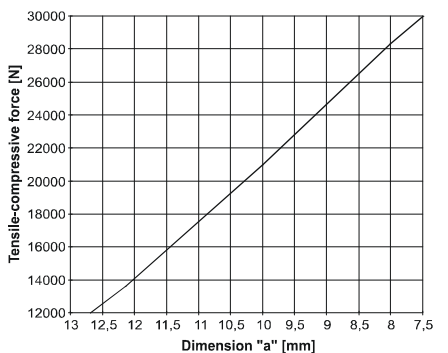

Size 5, Type 3 _ _ .6 _ _

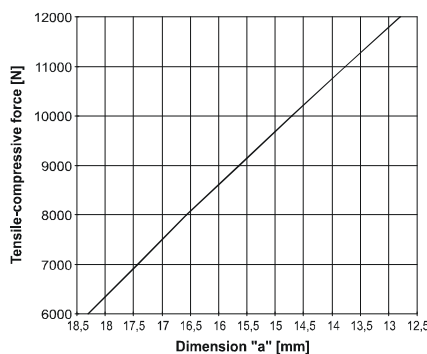

Size 6, Type 3 _ _ .4 _ _

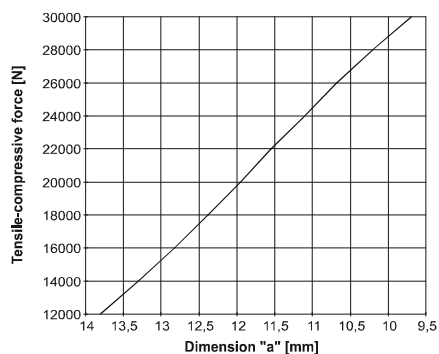

Size 6, Type 3 _ _ .5 _ _

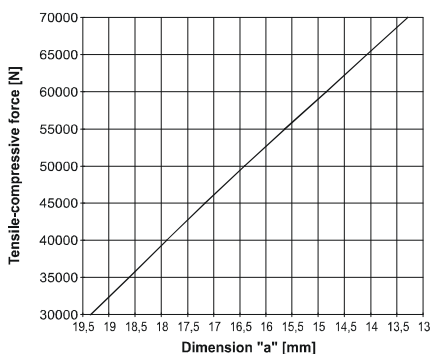

Size 6, Type 3 _ _ .6 _ _