

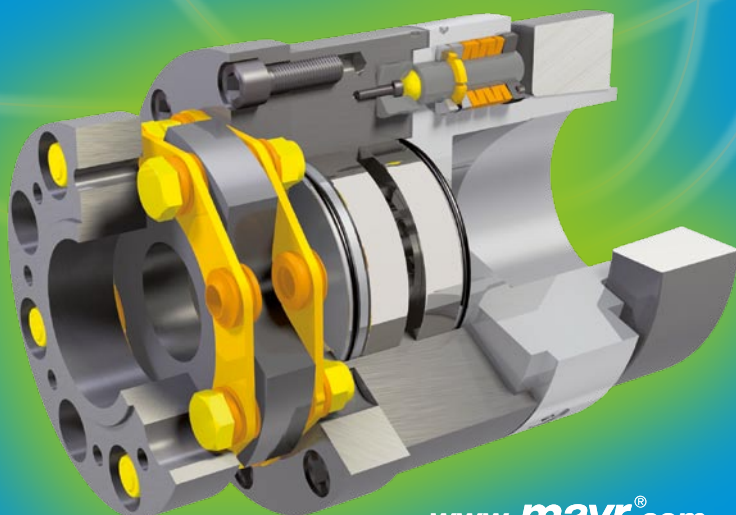

your reliable partner

EAS[®]-HSC/EAS[®]-HSE

High-speed safety clutches
for high-speed applications

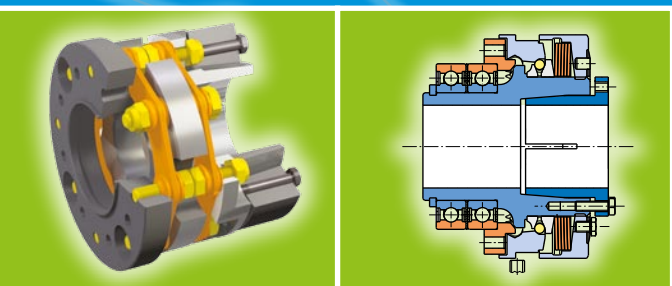

Construction and Development

Innovations for Your Success

With our innovative and economical solutions, we are able to set new records in the field of power transmission. Our many worldwide patents prove our constant ambition to develop better and technologically superior products.

Highly qualified engineers, high-performance 3D-CAD-systems and the most up-to-date FEM calculation aids used in our Development and Construction departments mean that our business is perfectly equipped to offer our customers effective solutions.

Experts for all Power Transmission Questions

Exploit our know-how, gained by decades of experience in the development, production and application of power transmission products. Our experts in Construction and Development are happy to advise you personally and competently when selecting and dimensioning the drive solution you require.

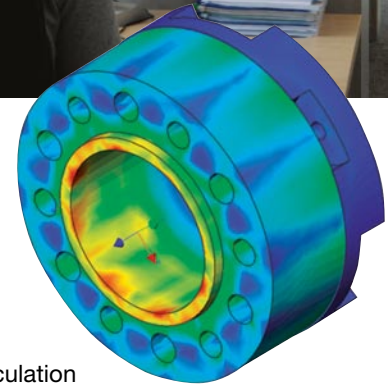
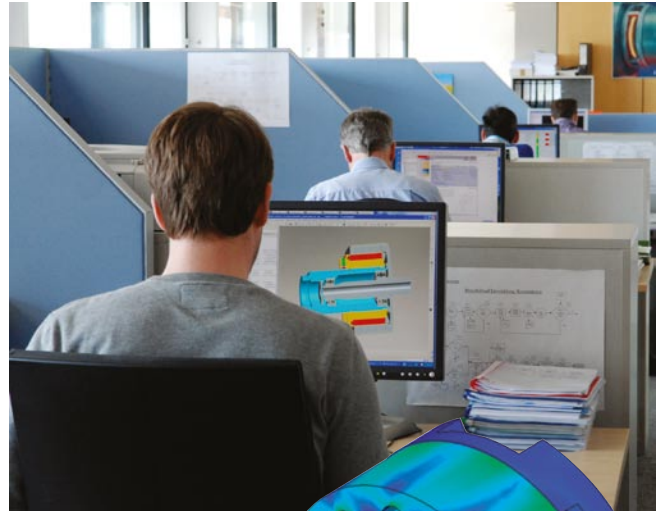

FEM-magnetic flow calculation for a ROBA-stop[®] safety brake

From Prototype to Finished Product

No mayr[®] product is released onto the market until it has proved its functional capabilities and reliability in extreme, long-term tests.

The spectrum of testing stands is as varied as our range of products:

- Friction work test stands
- Wear test stands
- Noise measurement room with highly accurate noise measurement inspection devices
- Torque inspection stands up to 200,000 Nm
- Impact alternating load test stands
- Force test stands
- Linear movement test stands
- Continuous performance test stands
- Magnetic flow measurement test stands
- High-speed test stands up to 20,000 rpm
- Misalignment and angular misalignment test stands
- Load and measurement test stands for DC motors

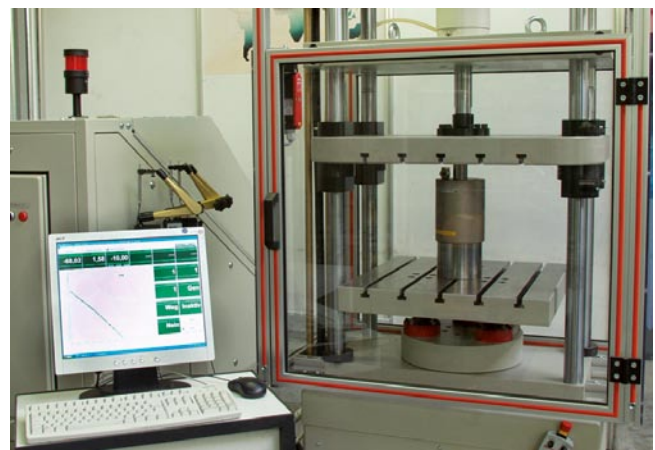

Product Data: Our 24-hour Service

Our website offers you detailed information 24 hours per day, 365 days per year with no delays. Here you can find not only the latest catalogues and technical documentation but also CAD-files for cost-saving construction of our products.

Unsurpassed - Our Standard Program

For safety clutches, safety brakes, backlash-free shaft couplings and high-quality DC drives, we offer you a complete product range with market and branch optimised constructions and designs.

EAS®-HSC / EAS®-HSE

The perfect safety clutches for all fast-running drives

Characteristics

- ❑ Positive locking overload clutch
- ❑ Complete separation
- ❑ Synchronous re-engagement
- ❑ Balanced when completely installed
- ❑ Diverse mounting variations
- ❑ High torsional rigidity
- ❑ High performance density
- ❑ Low mass moment of inertia
- ❑ High speeds of up to 12,000 rpm
(up to 20,000 rpm possible as special design)

Compact, with a high performance density

In comparison to the torque limiting clutches common on the market, the new EAS®-HSC and EAS®-HSE test stand clutches possess numerous special technical features. The extremely compact design of these clutches is immediately obvious. A high performance density reduces the rotating masses and has a positive effect on the running smoothness and machine dynamics.

High balance quality

The basic pre-requisite for the use of a torque limiting clutch in high-speed applications is amongst other things the high balance quality of each individual component in order to achieve optimum running smoothness of the drive line when these components are combined.

Torque limiting clutches consist of many individual components, which must not change their positions when the clutch is installed or after overload. This is ensured through design measures. In addition, the clutch is balanced in completely installed condition to a balance quality of G 2,5 - reference speed 3000 rpm.

Ideal for use in test stands

We specialise in the development of customer-tailored solutions. Contact us if our standard-design EAS®-HSC and EAS®-HSE clutches do not provide the optimum solution for your test stand.

We will modify our standard products precisely according to your wishes, or develop an economic, customer-specific solution especially for you.

Profit from our 50 years of experience in the development, manufacture and implementation of test stand clutches.

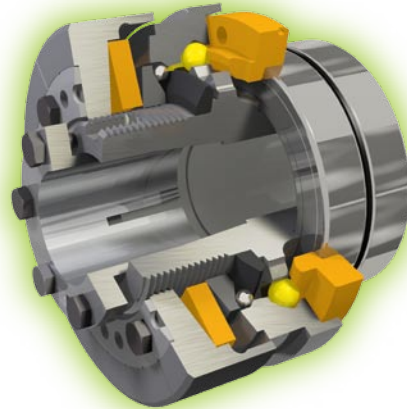

EAS®-HSC torque limiting clutch
Torque range: 5 Nm – 1,000 Nm
Speeds of up to 12,000 rpm

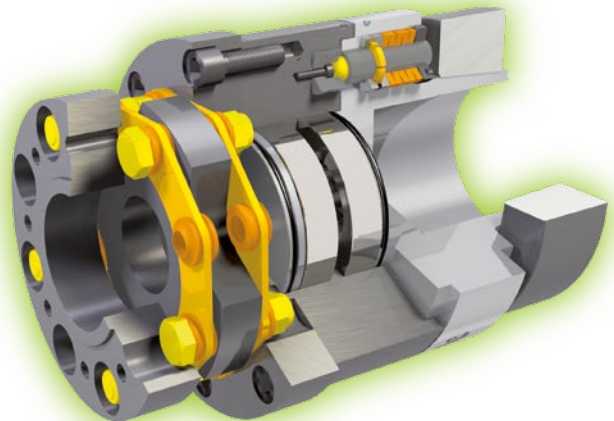

EAS®-HSE torque limiting clutch
Torque range: 100 Nm – 8,400 Nm
Speeds of up to 12,000 rpm (up to 20,000 rpm possible as special design).

Further test stand clutches and couplings

ROBA®-DS – torsionally rigid shaft coupling

ROBA®-DS shaft couplings transfer the nominal coupling torque using frictional locking and backlash-free even with full displacement and with alternating torques.

ROBA®-DSM – measuring machine element

Integrated into tried and tested, backlash-free shaft compensation couplings, the ROBA®-DSM permits condition monitoring of machines and systems.

ROBATIC® – electromagnetic clutch

Energised to engage, electromagnetic pole face clutch for static and virtually static applications.

Configuration possibilities

- EAS[®]-HSC
- EAS[®]-HSE
- ROBA[®]-DS

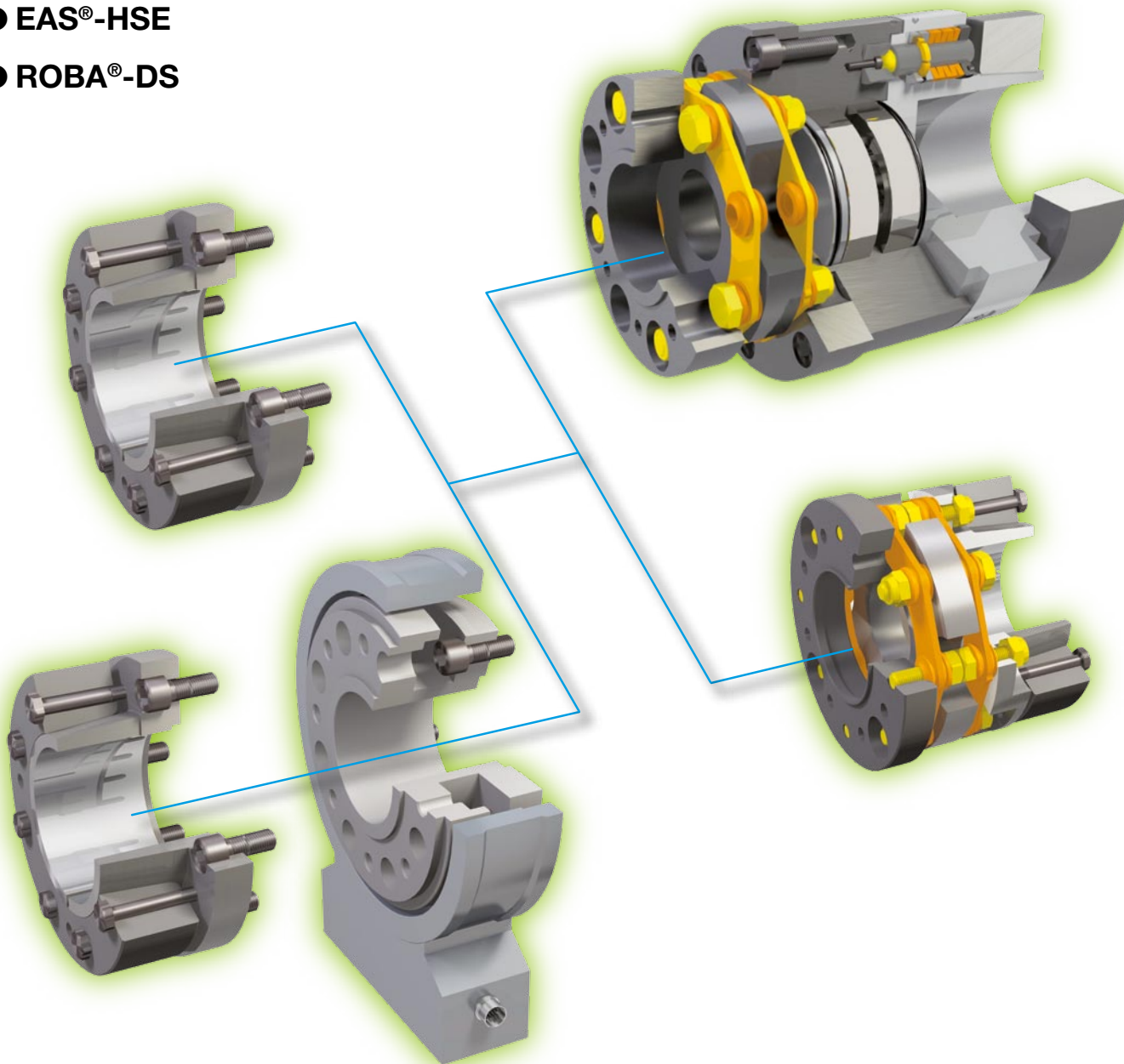

With torque measuring flange

The construction of the system permits extremely high flexibility with regard to the connection points (hubs) and the output-side mounting parts (shaft coupling, ROBA[®]-HSC and ROBA[®]-HSE).

Standard market torque measuring flanges can be adapted.

Contact **mayr**[®] to obtain more details on your measuring flange

EAS[®]-HSC

Function in case of overload

If the set limit torque is exceeded, the clutch disengages. The torque drops immediately. A mounted limit switch detects the disengagement movement and switches off the drive. The limit switch signal can also be used for other control functions.

The EAS[®]-HSC High-Speed-Compact completely disconnects the input and output side and remains in this condition until it is purposely re-engaged by hand or using devices.

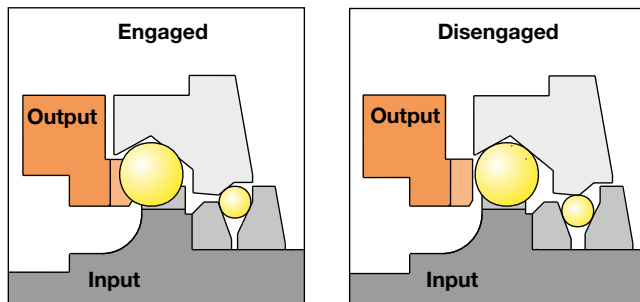

During operation, EAS[®]-HSC clutches transfer the torque backlash-free and ensure that the drive components slow down freely after overload.

During the overtravel time, no engagement impacts occur which might have a negative effect on the drive line.

The design permits re-engagement only at the disengagement position.

EAS[®]-HSE

Function in case of overload

- ❑ If the proportional circumferential force on the individual elements proves too large, the resulting axial force causes an axial movement of the bolt via the ball/calotte system and therefore the disconnection of the torque transmission.
- ❑ The maximum circumferential force is individually determined through the adjusting nut and *mayr*[®]-cup springs. The transmittable torque is determined in this way.
- ❑ Due to the axial stroke of the bolt (ball carrier), the control segments move radially outwards and thus cause axial overload.
- ❑ Re-engagement of the balls through a bolt stroke in the direction of the calotte takes place manually.

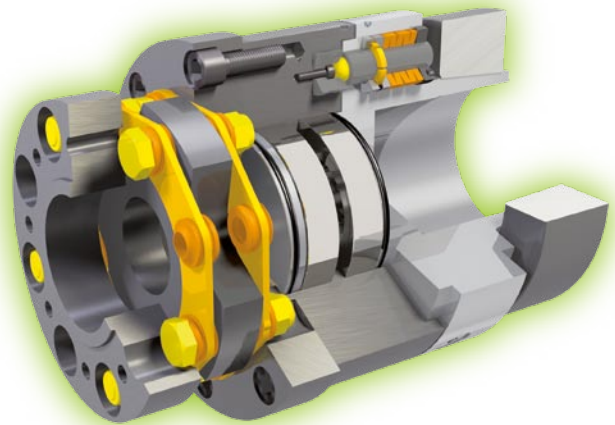
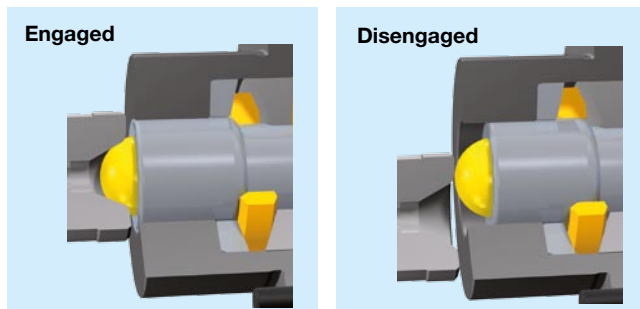

During operation, EAS[®]-HSE clutches transfer the torque with low backlash and ensure that the drive components slow down freely after overload.

Reliable, precise torque limitation through positive locking torque adjustment. Complete disconnection of the drive line on overload – no engagement impacts. Quick re-engagement without special tools being necessary. High balance quality.

Configuration possibilities/Standard designs EAS[®]-HSC

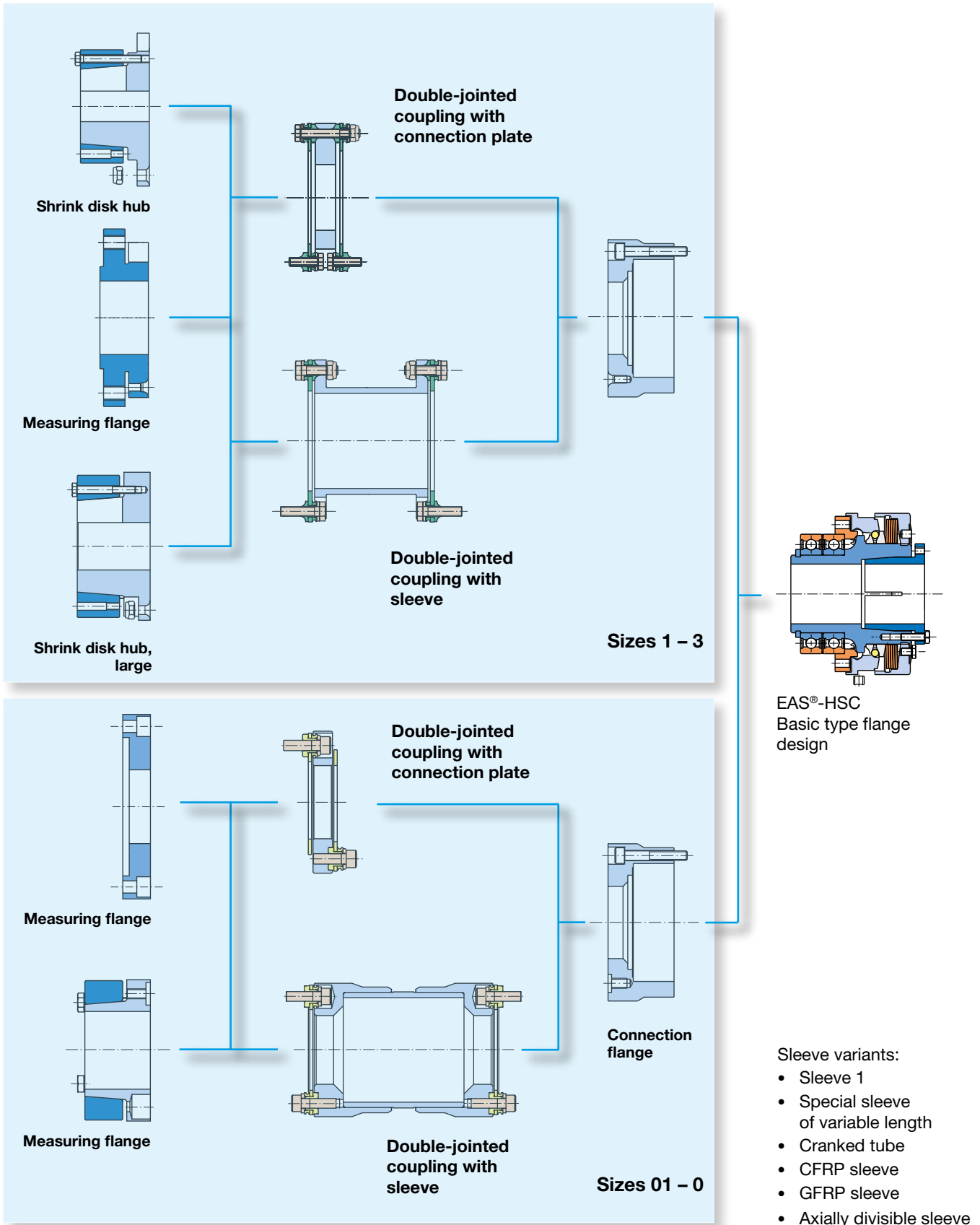

We are happy to advise you on the dimensioning and configuration of your optimum design.

Configuration possibilities/Standard designs EAS[®]-HSE

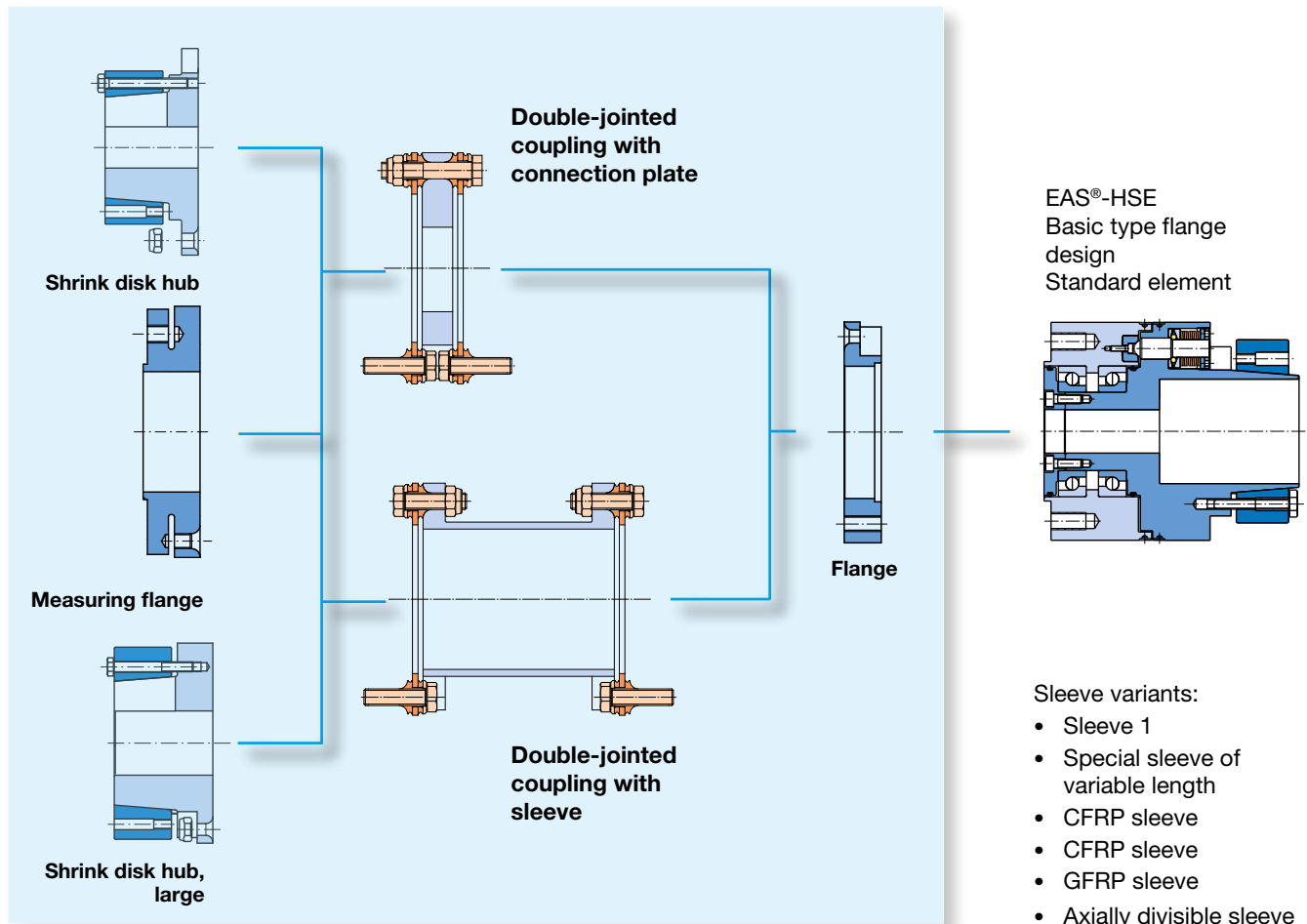

We are happy to advise you on the dimensioning and configuration of your optimum design.

EAS®-HSC

EAS®-side cone bushing: Type 4090_1300
 Basic type
 Sizes 01 to 3

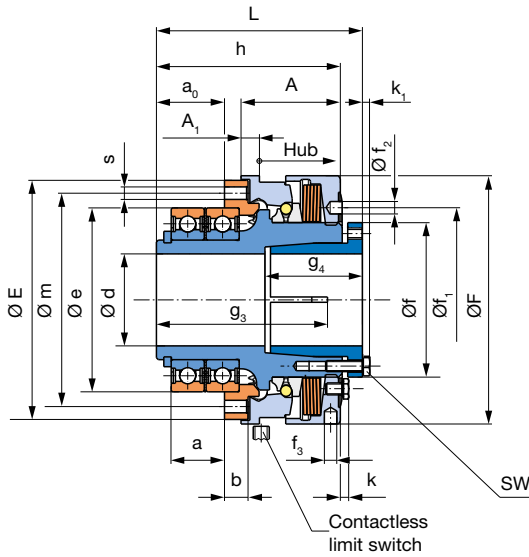

EAS®-side cone bushing: Type 4096_131₂
 ROBA®-DS-side shrink disk hub
 Sizes 01 to 3

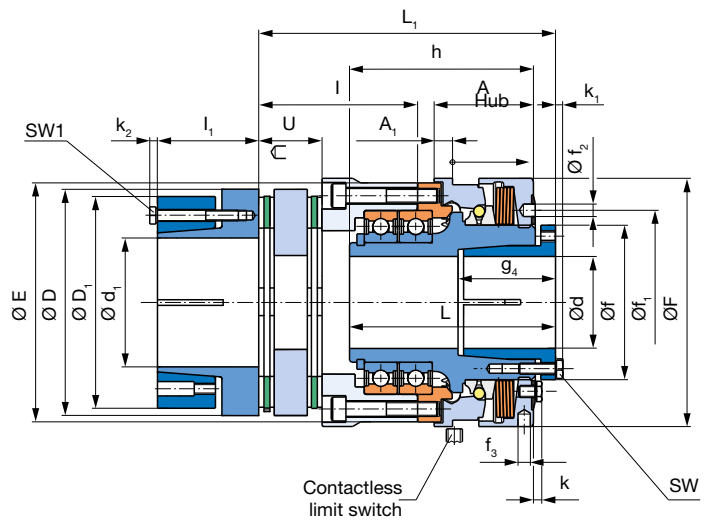

EAS®-side cone bushing: Type 4096_1319
 ROBA®-DS-side for measuring flange
 Sizes 1 to 3

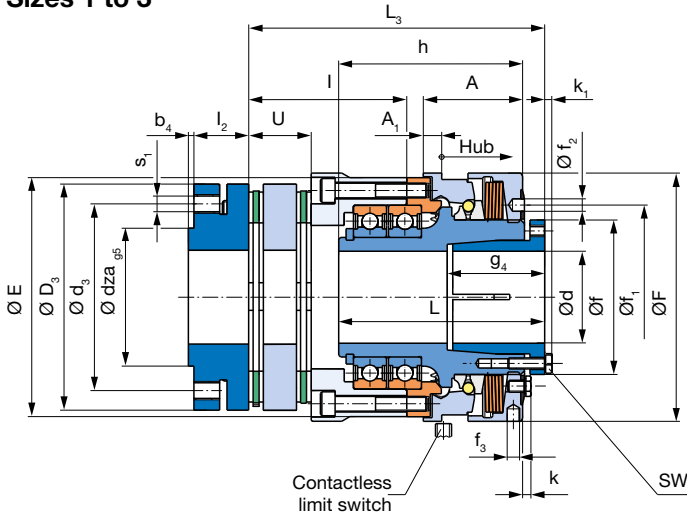

EAS®-side cone bushing: Type 4096_13__
 ROBA®-DS-side for measuring flange
 Sizes 01 to 0

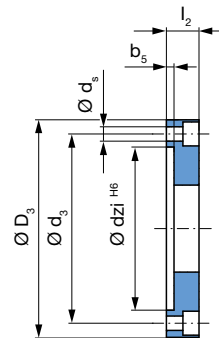

Order number

Cone bushing		1	0	Basic type		Torque adjustment value
Basic type ³⁾ with ROBA®-DS ⁴⁾	0 6		1 2	Connection plate Sleeve ²⁾		
_ / 4 0 9 _ . _ 1 3 _ _ / _ / _ / _ / _						
Sizes	Torque range¹⁾			Basic type	Bore	With limit switch,
01	Medium	5		Shrink disk hub	Hub 1	see pages
to	High	6		Measuring flange	Hub 2	13 – 14
3	Very high	7		Shrink disk hub, large	Ø d ^{H6}	(optional)
	Maximum ²⁾	8			Ø d ₁ ^{H6}	

Example: Order number 1 / 4096.61312.0 / 23 / 25 / 60 / limit switch 055.002.5

1) See Technical data, limit torque for overload M_G, other torques on request

2) When using a sleeve, please contact mayr®

3) With basic type, only 4090_1300 possible

4) Not possible with ROBA®-DS 4090_1300

Technical data				Size ¹⁾				
				01	0	1	2	3
Limit torques for overload ^{1) 2)}	Type 409_513 __	M _G	[Nm]	5 – 12,5	10 – 25	20 – 50	40 – 100	80 – 200
	Type 409_613 __	M _G	[Nm]	10 – 25	20 – 50	40 – 100	80 – 200	160 – 400
	Type 409_713 __	M _G	[Nm]	20 – 50	40 – 100	80 – 200	160 – 400	320 – 800
	Type 409_813 __	M _G	[Nm]	25 – 62,5	50 – 125	100 – 250	200 – 500	400 – 1000
Max. speed ¹¹⁾		n _{max}	[rpm]	12000	10000	9000	7000	6000
Max. speed	Type 409_813 __	n _{max}	[rpm]	8000	7000	6000	5000	4000
Thrust washer stroke on overload coupling			[mm]	2	2,6	3,2	3,8	4,3
Nominal torques, torsionally rigid coupling		T _{KN}	[Nm]	100	150	420	650	1000
Permitted misalignments	axial ¹²⁾	ΔK _a	[mm]	0,3	0,35	0,3	0,35	0,4
	radial	ΔK _r	[mm]	0,06	0,05	0,05	0,08	0,1
	angular	ΔK _w	[°]	0,3	0,6	0,45	0,45	0,45

Mass moments of inertia and weights ¹⁰⁾				Size				
				01	0	1	2	3
EAS [®] -hub-side	Type 4090_1300	I	[10 ⁻³ kgm ²]	0,448	1,210	2,572	5,171	11,412
EAS [®] -pressure flange-side	Type 4090_1300	I	[10 ⁻³ kgm ²]	0,101	0,560	0,777	1,416	2,800
ROBA [®] -DS-side	Type 4096_1312/9	I	[10 ⁻³ kgm ²]	0,856	1,839	3,887	8,213	17,344
	Type 4096_1316	I	[10 ⁻³ kgm ²]	0,863	1,655	3,847	8,517	15,444
Weights	Type 4090_1300	m	[kg]	0,973	1,770	2,765	3,968	6,340
	Type 4096_1312/9	m	[kg]	2,071	3,421	5,529	8,260	12,983
	Type 4096_1316	m	[kg]	1,893	3,211	5,442	8,194	12,364

Tensioning screws and screw-on bores				Size				
				01	0	1	2	3
In cone bushing, EAS [®] -side	Quantity, dimension	M	[mm]	6 x M4	6 x M4	8 x M4	8 x M5	8 x M6
	Wrench opening	SW	[mm]	7	7	7	8	10
	Tightening torque	T _A	[Nm]	4	4	4	8	12
In shrink disk, ROBA [®] -DS-side	Quantity, dimension	M ₁	[mm]	4 x M5	6 x M5	6 x M5	6 x M5	6 x M6
	Wrench opening	SW ₁	[mm]	8	8	8	8	10
	Tightening torque	T _A	[Nm]	6	6	8,5	8,5	14
Screw-on bores in pressure flange	Quantity, dimension	s	[mm]	12 x M4	12 x M5	12 x M6	12 x M6	12 x M8
	Pitch			8 x 45° / 6 x 60°				

Dimensions [mm]	Size					
	01	0	1	2	3	
A	34	40	45	50	55	
A ₁	8	9	10	10	10	
a ⁵⁾	15	20	26	29	29	
a ₀	18	24	31	35	37	
b	6	7	9	10	12	
E	65	80	95	110	130	
e _{h5} ⁶⁾	47	62	75	90	100	
F	70	85	100	115	135	
f	38	44	56	70	84	
f ₁	50	55	70	84	100	
f ₂	5	5	5	6	7	
f ₃	4	6	6	6	6	
Pitch	4 x 90°					
Minimum shaft length	g ₃	50	60	76	83	93
	g ₄	34	39	42	48	53
h	55	68	82	91	101	
k	2,8	2,8	3,5	4,0	4,0	
k ₁	2,8	2,8	2,8	3,5	4,0	
L ⁷⁾	62	76	90	100	112	
m	56	71	85	100	116	

Dimensions [mm]	Size					
	01	0	1	2	3	
ROBA [®] -DS	10	15	25	40	64	
Type 4096_1312/9	D	69	79	89	104	123
	D ₁ ⁸⁾	68	78	82	100	115
	D ₁ ⁹⁾	68	78	64	74	84
	k ₂	3,5	3,5	3,5	3,5	4
	L ₁ ⁷⁾	88,3	103	123	138,8	161
	l	44,3	51	64	73,8	86
	l ₁ ⁸⁾	32	37,5	45	50	55
	l ₁ ⁹⁾	32	37,5	40	45	50
	U	15,3	15,8	22	26,2	34
	Type 4096_1316	b ₄	-	-	2	2
b ₅		3,5	3,5	-	-	-
D ₃		100	100	99	123	123
d ₃		87	87	84	101,5	101,5
s ₁		6,6	6,6	M8	M10	M10
Pitch		8 x 45°				
		6 x 60°				
dza ^{g5}		-	-	57	75	75
dzi ^{h6}		75	75	-	-	-
l ₂		15	19	25	30,2	29,8

Bores [mm]	Size						
	01	0	1	2	3		
EAS [®] -side	d ^{H6 2) 4)}	d _{min}	10	15	22	32	35
		d _{max}	20	25	35	45	55
ROBA [®] -DS-side	ROBA [®] -DS	10 15 25 40 64					
		d ₁ ^{H6 3) 8)}	d _{1 min}	19	25	32	40
	d ₁ ^{H6 3) 9)}	d _{1 max}	38	45	52	60	70
		d _{1 min}	19	25	20	25	30
	d _{1 max}	38	45	36	45	45	

- Further sizes for smaller and larger torques available on request
- Observe shaft load in maximum torque range
- Shaft tolerance up to Ø 38_{h6} over Ø 38_{h8}
- Transmittable torques available with smaller bores on request
- Mounting tolerance + 0,1
- Tolerance user-side H6
- Dimensions in released condition (shorter in tensioned condition)
- Only valid for type 4096_13_9
- Only valid for type 4096_13_2
- Mass moments of inertia and weights apply for maximum bore
- Higher speeds available on request
- Only permitted as a static or virtually static value

We reserve the right to make dimensional and constructional alterations.

EAS[®]-HSE

EAS[®]-side shrink disk hub: Type 4030.60400
Basic type
Sizes 02 to 0

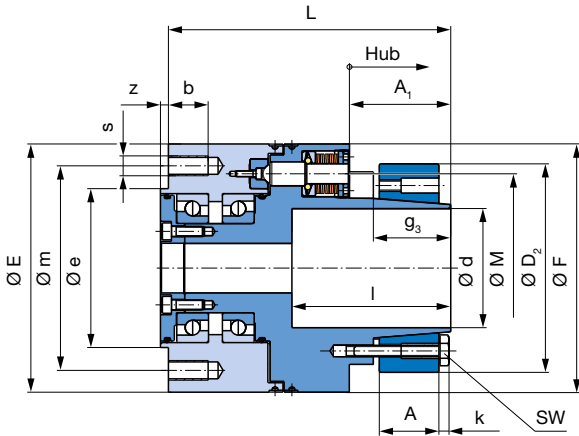

EAS[®]-side shrink disk hub: Type 4036.60419
ROBA[®]-DS-side shrink disk hub
Sizes 02 to 0

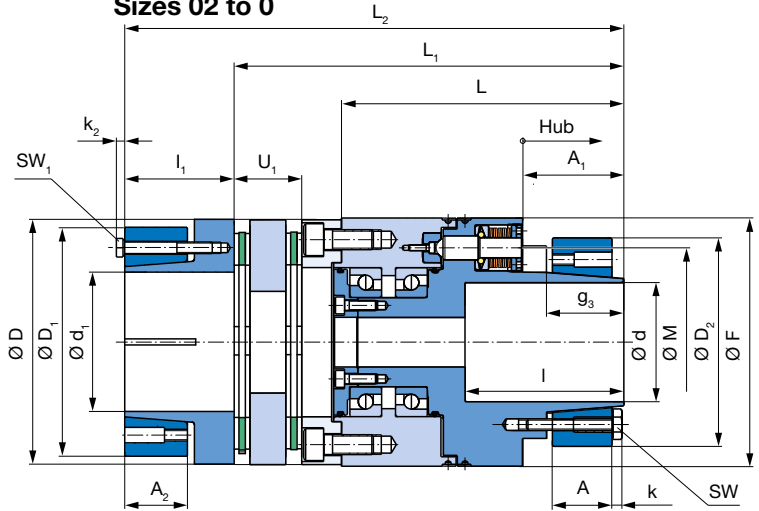

EAS[®]-side shrink disk hub: Type 4036.60416
ROBA[®]-DS-side for measuring flange
Sizes 02 to 0

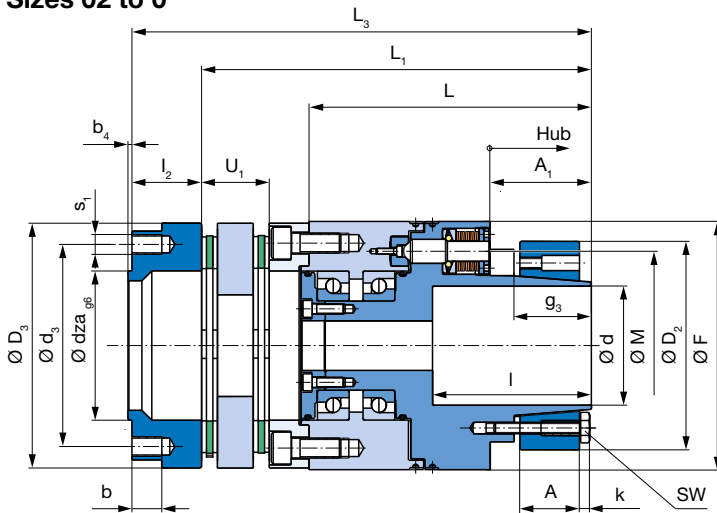

Order number

Standard element		0	0	Basic type	Torque adjustment value	
Basic type ³⁾ with ROBA [®] -DS ⁴⁾	0	0	4	1		Connection plate
	6			2		Sleeve ²⁾
 / 4 0 3 . 0 4 / / / 						
Sizes	Torque range ¹⁾³⁾					
02	Medium	4	Basic type	0	Bore	
to	High	5	Shrink disk hub	2	Hub 1	
0	Very high	6	Measuring flange	6	Ø d ^{H6}	
	Maximum	7	Shrink disk hub, large	9	Ø d ₁ ^{H6}	

Example: Order number 1 / 4036.60416 / 52 / 70 / 1250

1) See Technical data, limit torque for overload $M_{G,}$ other torques on request
2) When using a sleeve, please contact *mayr*[®]

3) With basic type, only 4030_0400 possible
4) Not possible with ROBA[®]-DS 4030_0400

Technical data		EAS®-element				Size ¹⁾						
		Number	Type			02	01	0				
Limit torques for overload ^{1) 2)}	Type 403_404 _	2	440.604.0	M _G	[Nm]	100 – 250	325 – 650	1400 – 2800	–			
	Type 403_504 _	4	440.604.0	M _G	[Nm]	250 – 500	685 – 1250	2800 – 5600	–			
	Type 403_604 _	6	440.604.0	M _G	[Nm]	375 – 750	1000 – 2000	–	4200 – 8400			
	Type 403_704 _	8	440.604.0	M _G	[Nm]	500 – 1000	1250 – 2500	–	–			
EAS®-element (Size)						02	01	0				
Max. speed ¹⁰⁾						n _{max}	[rpm]	12000	10000	7000	7000	
Bolt stroke on overload							[mm]	2,5	4	6	6	
Nominal torques, torsionally rigid coupling						T _{KN}	[Nm]	1100	2600	5800	9500	
Permitted misalignments						axial ¹¹⁾	ΔK _a	[mm]	0,4	0,5	0,45	0,5
						radial	ΔK _r	[mm]	0,1	0,1	0,1	0,1
						angular	ΔK _w	[°]	0,4	0,4	0,3	0,3

Tensioning screws and screw-on bores				Size			
				02	01	0	
In shrink disk, EAS®-side	Quantity, dimension	M	[mm]	4 × M8	8 × M8	8 × M12	
	Wrench opening	SW	[mm]	13	13	19	
	Tightening torque	T _A	[Nm]	36	36	93	
In shrink disk, ROBA®-DS-side	Quantity, dimension	M ₁	[mm]	6 × M6	6 × M8	8 × M10	8 × M12
	Wrench opening	SW ₁	[mm]	10	13	17	19
	Tightening torque	T _A	[Nm]	10	36	56	93
Screw-on bores in pressure flange	Pitch, dimension	s	[mm]	6 × 60° M10	6 × 60° M14	8 × 45° M20	8 × 45° M20

Mass moments of inertia and weights ⁹⁾				Size			
				02	01	0	
EAS®-hub-side	Type 4030_04 _	I	[10 ⁻³ kgm ²]	10,271	47,180	341,804	
EAS®-pressure flange-side	Type 4030_04 _	I	[10 ⁻³ kgm ²]	8,081	37,321	233,775	
ROBA®-DS-side	ROBA®-DS			64	160	500	850
	Type 4036_0416	I	[10 ⁻³ kgm ²]	10,223	40,896	193,757	281,625
	Type 4036_041 ² / ₉	I	[10 ⁻³ kgm ²]	12,024	53,899	241,013	405,591
Weights	Type 4030_0400_	m		8,77	22,457	68,790	
	Type 4036_0416	m	[kg]	13,220	32,154	93,939	100,044
	Type 4036_041 ² / ₉	m	[kg]	14,083	84,615	102,578	115,994

Dimensions [mm]	Size		
	02	01	0
A	30	38	63
A ₁	51	63,4	89
L	142,2	182,4	250
z	4	4	5
b	20	25	42
M	95	133	190
D ₂	105	141	234
l	80	100	130
g ₃	40	50	75
k	5,3	5,3	7,5
E	125	170	250
e _{hb} ⁶⁾	80	105	160
F	125	170	250
m	103	140	210

Dimensions [mm]	Size					
	02	01	0			
ROBA®-DS	64	160	500	850		
Type 4036_131 ² / ₉	D	123	167	198	234	
	D ₁ ⁷⁾	115	162	198	234	
	D ₁ ⁸⁾	84	118	198	234	
	L ₁	162,2	250,8	344	359	
	L ₂ ⁷⁾	251,2	320,8	439	474	
	L ₂ ⁸⁾	246,2	310,8	439	474	
	U ₁	34	40,4	52	65	
	l ₁ ⁷⁾	55	70	95	115	
	l ₁ ⁸⁾	50	60	95	115	
	k ₂	4	5,3	6,4	7,5	
	A ₂	31,5	39	51	63	
	Type 4036_1316	dza _{g6}	75	90	110	140
		d ₃	101,5	130	155,5	196
		D ₃	123	167	210	252
b ₄		2	2,8	2,8	3	
b		15	14	26	29	
s ₁		Pitch	8 × 45°			
		Dimension	M10	M12	M14	M16
		l ₂	35	35	36	29
L ₃		231,2	285,8	380	388	

Bores [mm]	Size					
	02	01	0			
EAS®-side	d ^{H7/2)}	d _{min}	48	47	70	
		d _{max}	60	75	120	
ROBA®-DS-side	d ₁ ^{H7/3) 7)}	ROBA®-DS				
		d _{1 min}	45	65	60	70
		d _{1 max}	70	100	100	120
		d ₁ ^{H7/3) 8)}	d _{1 min}	30	40	60
		d _{1 max}	45	65	100	120

- Further sizes for smaller and larger torques available on request
- Observe shaft load in maximum torque range
- Shaft tolerance up to Ø 38_{h6}, over Ø 38_{h8}
- Transmittable torques available with smaller bores on request
- Mounting tolerance + 0,1
- Tolerance user-side H6
- Only valid for type 4096_13_9
- Only valid for type 4096_13_2
- Mass moments of inertia and weights apply for maximum bore
- Higher speeds available on request
- Only permitted as a static or virtually static value

We reserve the right to make dimensional and constructional alterations.

Other test stand clutches and couplings

ROBA[®]-DSM

Torque measurement coupling

Measurement ranges 190 Nm – 1,600 Nm

Accuracy < 1 %

Bandwidth 3.5 kHz, usable resolution 12 Bit

- Integrated into tried and tested, backlash-free shaft compensation coupling
- Simple electrical and mechanical installation
- Robust and reliable machine element
- Absolutely maintenance-free

Can be combined with ROBA[®]-DS shaft couplings and EAS[®]-torque limiting clutches

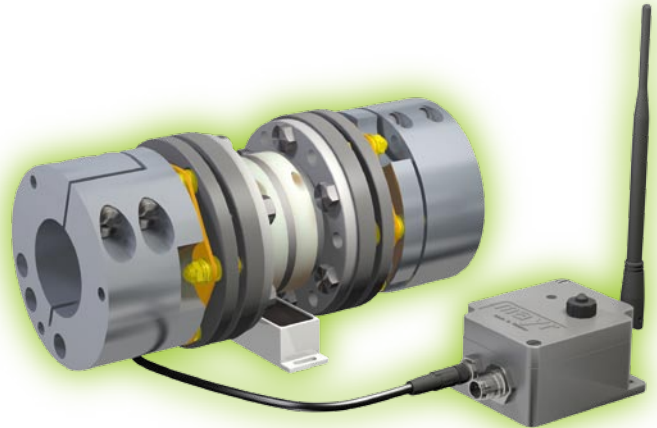

For detailed Technical data, see Catalogue

ROBA[®]-DSM **P.971005.V** _ _ _ _

ROBATIC[®]-electromagnetic clutch

Torque range 10 Nm – 640 Nm

Speeds up to 8,600 rpm

- Short switching times/high switching frequency
- High performance density
- Large permitted shaft diameter
- High torque reliability
- Simple installation
- Compact construction

For detailed technical data, see Catalogue

ROBATIC[®] **K.500.V** _ _ _ _

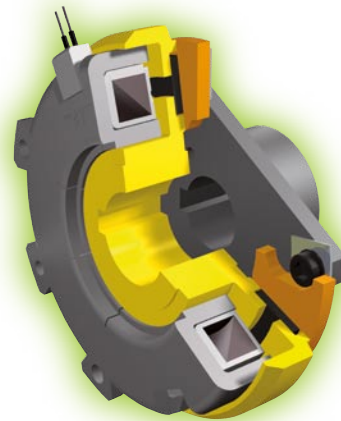

ROBA[®]-DS shaft coupling

Torque range 3 Nm - 110,000 Nm

Speeds up to 13,600 rpm

- Resistant to alternating loads up to 100% of the nominal torque, up to Size 2200
- Low mass moment of inertia due to high performance density
- Completely backlash-free up to the nominal torque
- High misalignment compensation capability with low restoring forces
- High torsional rigidity up to the nominal torque
- Completely wear-free and maintenance-free
- Optimum design due to high diversity of variants

For detailed technical data, see Catalogue

ROBA[®]-DS **K.950.V** _ _ _ _

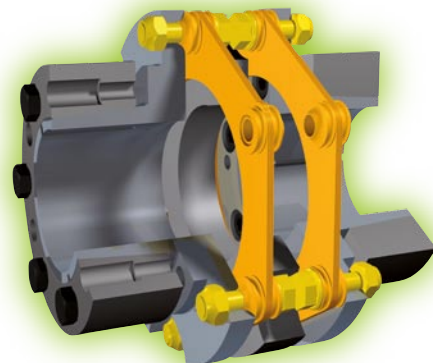

ROBA[®]-DS shaft couplings transmit the coupling nominal torque using frictional locking and backlash-free even with full displacement and alternating torques. The maximum performance density permits the use of the respective smallest size. The mass moment of inertia and the diameter are minimised.

Maximum running smoothness due to highly precise components and complete balancing.

Limit Switch Type 055.00_.5 (contactless)

Application

This device is used for measuring and monitoring axial and radial disengaging movements, e.g. on EAS®-clutches. It acts as a control sensor for electronic and mechanical sequences.

Function

When the sensor surface of the NAMUR sensor scans a metal control flag (damped), the signal relay is triggered, is deenergised and drops. Contacts 1 - 2 are opened. Damping is possible from all sides.

Electrical Connection (Terminal)

1 - 2 - 3 floating changeover-contacts
5 - 6 Connection input voltage

Design

The electronic amplifier is installed in a light metal housing. The limit switch is fixed using two screw-on mounting links attached diagonally with M4 cap screws.

Technical Data

Input voltage (dependent on design)	230 VAC, ±10 %, 50–60 Hz 115 VAC, ±10 %, 50–60 Hz 24 VDC, PELV, ±5 %, protected against reverse polarity, for overvoltage category II connection
Power consumption	max. 1,5 VA
Ambient temperature	-10 °C bis +60 °C limit switch -25 °C bis +60 °C NAMUR sensor
Protection	IP 54
Conductor cross-section	max. 2,5 mm ² / AWG 14
Weight	400 g / 14 oz
Protection fuse	0,1 A/fast acting at 24 VDC (in system)
Signalling relay	Potential-free two-way contacts Contact load max. 250 VAC/12 A Contact material AgNi 90/10 max. switching frequency 20 Hz at min. load, 0,1 Hz at max. load
NAMUR sensor internal	Installed in a light metal housing, operating distance SN 2 mm, flush fitting, max. switching frequency 2 kHz, the zero point can be set per 1 mm by means of the lateral adjusting screw SW 7
NAMUR sensor external	metal housing M12 x 1, operating- distance SN 2 mm, flush fitting, max. switching frequency 2 kHz, standard cable length 2 m, max. 100 m with special design, protection IP 67

Installation

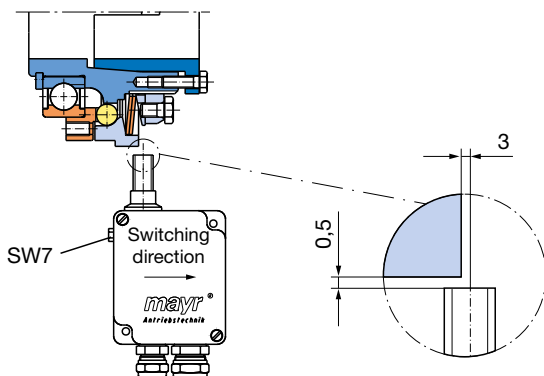

Dimensions (internal NAMUR sensor)

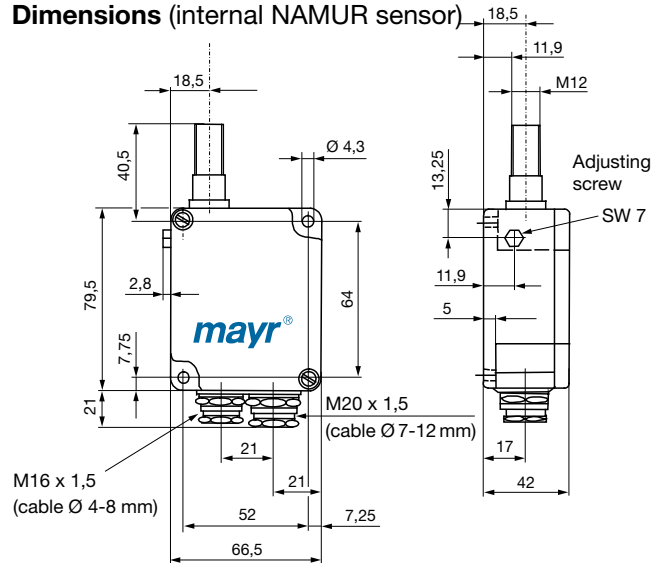

Dimensions (external NAMUR sensor)

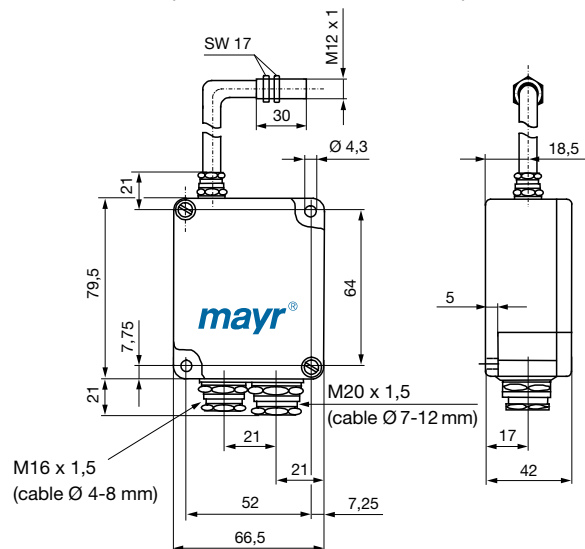

Order number

0 5 5 . 0 0 _ . 5 / _

Contactless sensing		Connection voltage	
Sensor external	1	230 VAC	
Sensor internal	2	115 VAC	
		24 VDC	

Limit Switch Type 055.012.6 (Contactless, with mounting flange)

Application

The inductive proximity switch monitors and detects operating conditions on EAS[®] overload clutches. Axial movements caused by overload or switching procedures are registered by the proximity switch. The signal can be used for further process controlling e.g. for drive switch-off.

Function

When the overload clutch disengages, the inductive proximity switch converts from a damped to an undamped condition and the signal level on the output (2) changes from the input voltage value to 0V.

Electrical Connection

1	L+	BN (brown)
2	NO contact	BK (black)
3	L-	BU (blue)

Technical Data

Identification code	NBB1,5-8GM30-E2-Y
Construction size	M8 x 1
Type of construction	Rustproof stainless steel
Input voltage	10 – 30 VDC PELV
No-load current	≤ 15 mA
Power capacity	100 mA
Contact type	PNP/NO contact
Switching distance S_n	1,5 mm, flush installation
Assured switching distance S_a	1,2 mm
Characteristics	Inverse polarity protection Clocking short circuit protection Switching condition indicator via LED
Connection type	Cable 3 m/PUR
Tightening torque	10 Nm
Connection cross-section	0,14 mm ² / AWG 26
Ambient temperature	-25 °C bis +70 °C
Protection	IP 67
Accessories	Mounting flange

Dimensions (mm)

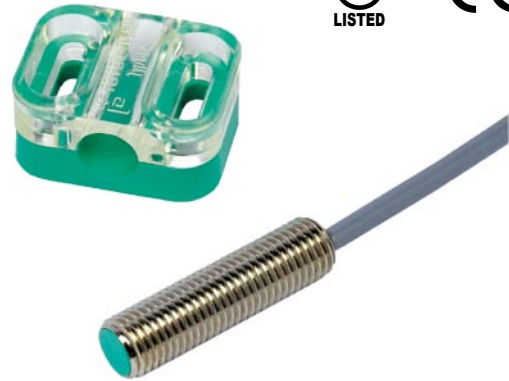
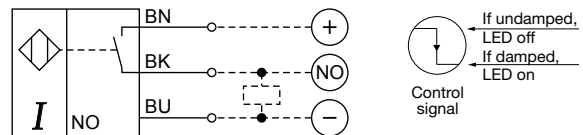
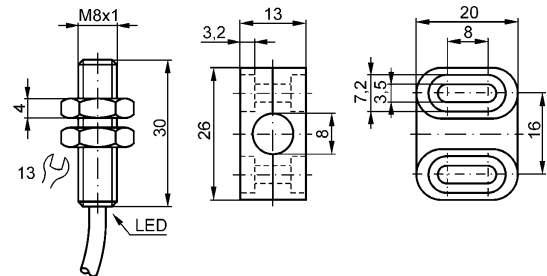

Installation

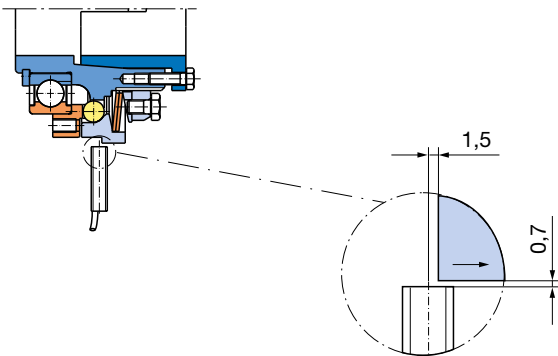

Order number

0 5 5 . 0 1 2 . 6 / _



Connection voltage
10 – 30 VDC

Product Summary

Safety Clutches/Overload Clutches

- **EAS®-Compact®/EAS®-NC**
Positive locking and completely backlash-free torque limiting clutches
- **EAS®-smartic®**
Cost-effective torque limiting clutches, quick installation
- **EAS®-element clutch/EAS®-elements**
Load-disconnecting protection against high torques
- **EAS®-axial**
Exact limitation of tensile and compressive forces
- **EAS®-Sp/EAS®-Sm/EAS®-Zr**
Load-disconnecting torque limiting clutches with switching function
- **ROBA®-slip hub**
Load-holding, frictionally locked torque limiting clutches
- **ROBA®-contitorque**
Magnetic continuous slip clutches

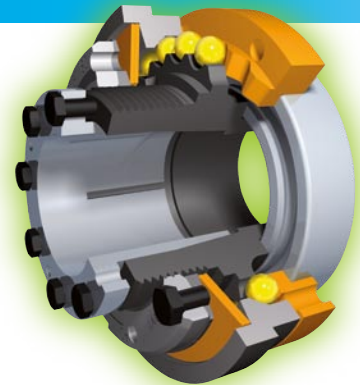

Shaft Couplings

- **smartflex®**
Perfect precision couplings for servo and stepping motors
- **ROBA®-ES**
Backlash-free and damping for vibration-sensitive drives
- **ROBA®-DS/ROBA®-D**
Backlash-free, torsionally rigid all-steel couplings
- **EAS®-control-DS**
Cost-effective torque-measuring couplings

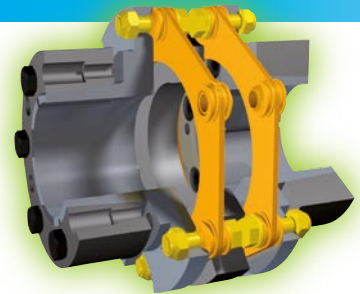

Electromagnetic Brakes/Clutches

- **ROBA-stop® standard**
Multifunctional all-round safety brakes
- **ROBA-stop®-M motor brakes**
Robust, cost-effective motor brakes
- **ROBA-stop®-S**
Water-proof, robust monoblock brakes
- **ROBA-stop®-Z/ROBA-stop®-silenzio®**
Doubly safe elevator brakes
- **ROBA®-diskstop®**
Compact, very quiet disk brakes
- **ROBA®-topstop®**
Brake systems for gravity loaded axes
- **ROBA®-linearstop**
Backlash-free brake systems for linear motor axes
- **ROBATIC®/ROBA®-quick/ROBA®-takt**
Electromagnetic clutches and brakes, clutch brake units

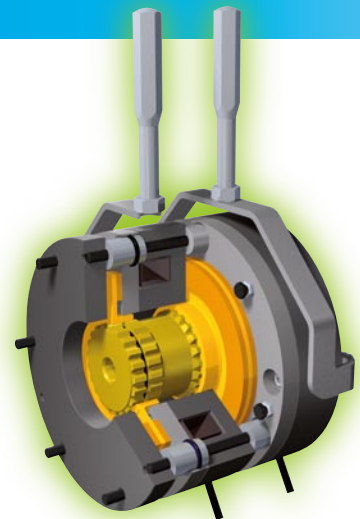

DC Drives

- **tendo®-PM**
Permanent magnet-excited DC motors
- **tendo®-SC**
1 quadrant and 4 quadrant transistor controllers

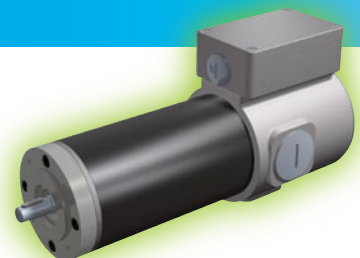

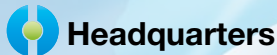

Headquarters

Chr. Mayr GmbH + Co. KG
Eichenstrasse 1, D-87665 Mauerstetten
Tel.: +49 83 41/8 04-0, Fax: +49 83 41/80 44 21
www.mayr.com, E-Mail: info@mayr.com



your reliable partner

Service Germany

Baden-Württemberg

Esslinger Straße 7
70771 Leinfelden-Echterdingen
Tel.: 07 11/45 96 01 0
Fax: 07 11/45 96 01 10

Bavaria

Eichenstrasse 1
87665 Mauerstetten
Tel.: 0 83 41/80 41 04
Fax: 0 83 41/80 44 23

Chemnitz

Bornaer Straße 205
09114 Chemnitz
Tel.: 03 71/4 74 18 96
Fax: 03 71/4 74 18 95

Franken

Unterer Markt 9
91217 Hersbruck
Tel.: 0 91 51/81 48 64
Fax: 0 91 51/81 62 45

Hagen

Im Langenstück 6
58093 Hagen
Tel.: 0 23 31/78 03 0
Fax: 0 23 31/78 03 25

Kamen

Lünener Strasse 211
59174 Kamen
Tel.: 0 23 07/23 63 85
Fax: 0 23 07/24 26 74

North

Schiefer Brink 8
32699 Extertal
Tel.: 0 57 54/9 20 77
Fax: 0 57 54/9 20 78

Rhine-Main

Hans-Böckler-Straße 6
64823 Groß-Umstadt
Tel.: 0 60 78/7 82 53 37
Fax: 0 60 78/9 30 08 00

Branch office

China

Mayr Zhangjiagang
Power Transmission Co., Ltd.
Changxing Road No. 16,
215600 Zhangjiagang
Tel.: 05 12/58 91-75 65
Fax: 05 12/58 91-75 66
info@mayr-ptc.cn

Great Britain

Mayr Transmissions Ltd.
Valley Road, Business Park
Keighley, BD21 4LZ
West Yorkshire
Tel.: 0 15 35/66 39 00
Fax: 0 15 35/66 32 61
sales@mayr.co.uk

France

Mayr France S.A.
Z.A.L. du Minopole
Rue Nungesser et Coli
62160 Bully-Les-Mines
Tel.: 03.21.72.91.91
Fax: 03.21.29.71.77
contact@mayr.fr

Italy

Mayr Italia S.r.l.
Viale Veneto, 3
35020 Saonara (PD)
Tel.: 0498/79 10 20
Fax: 0498/79 10 22
info@mayr-italia.it

Singapore

Mayr Transmission (S) PTE Ltd.
No. 8 Boon Lay Way Unit 03-06,
TradeHub 21
Singapore 609964
Tel.: 00 65/65 60 12 30
Fax: 00 65/65 60 10 00
info@mayr.com.sg

Switzerland

Mayr Kupplungen AG
Tobelackerstrasse 11
8212 Neuhausen am Rheinfall
Tel.: 0 52/6 74 08 70
Fax: 0 52/6 74 08 75
info@mayr.ch

USA

Mayr Corporation
4 North Street
Waldwick
NJ 07463
Tel.: 2 01/4 45-72 10
Fax: 2 01/4 45-80 19
info@mayrcorp.com

Representatives

Australia

Regal Beloit Australia Pty Ltd.
19 Corporate Ave
03178 Rowville, Victoria
Australien
Tel.: 0 3/92 37 40 00
Fax: 0 3/92 37 40 80
salesAUvic@regalbeloit.com

India

National Engineering
Company (NENCO)
J-225, M.I.D.C.
Bhosari Pune 411026
Tel.: 0 20/27 13 00 29
Fax: 0 20/27 13 02 29
nenco@nenco.org

Japan

MATSUI Corporation
2-4-7 Azabudai
Minato-ku
Tokyo 106-8641
Tel.: 03/35 86-41 41
Fax: 03/32 24 24 10
k.goto@matsui-corp.co.jp

Netherlands

Groneman BV
Amarilstraat 11
7554 TV Hengelo OV
Tel.: 074/2 55 11 40
Fax: 074/2 55 11 09
aandrijftechniek@groneman.nl

Poland

Wamex Sp. z o.o.
ul. Pozaryskiego, 28
04-703 Warszawa
Tel.: 0 22/6 15 90 80
Fax: 0 22/8 15 61 80
wamex@wamex.com.pl

South Korea

Mayr Korea Co. Ltd.
Room No.1002, 10th floor,
Nex Zone, SK TECHNOPARK,
77-1, SungSan-Dong,
SungSan-Gu, Changwon, Korea
Tel.: 0 55/2 62-40 24
Fax: 0 55/2 62-40 25
info@mayrkorea.com

Taiwan

German Tech Auto Co., Ltd.
No. 28, Fenggong Zhong Road,
Shengang Dist.,
Taichung City 429, Taiwan R.O.C.
Tel.: 04/25 15 05 66
Fax: 04/25 15 24 13
abby@zfgta.com.tw

Czech Republic

BMC - TECH s.r.o.
Hviezdoslavova 29 b
62700 Brno
Tel.: 05/45 22 60 47
Fax: 05/45 22 60 48
info@bmc-tech.cz

More representatives:

Austria, Belgium, Brazil, Canada, Denmark, Finland, Greece, Hongkong, Hungary, Indonesia, Israel, Luxembourg, Malaysia, New Zealand, Norway, Philippines, Romania, Russia, Slovakia, Slovenia, South Africa, Spain, Sweden, Thailand, Turkey

You can find the complete address for the representative responsible for your area under www.mayr.com in the internet.