



your reliable partner

Safety Brake in Accordance with the Machinery Directive

ROBA®-topstop®
Type 899. _ _ _ . _ _ _
Sizes 100 - 260

Issue status 2018-02

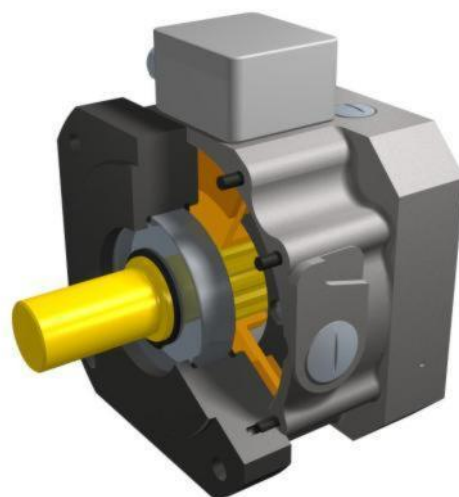

Prototype inspection by the DGUV
(German Social Accident Insurance):
Patents applied for



Translation of the Original Operational Instructions

B.8.8.EN

© Copyright by mayr® – power transmission

All rights reserved.

Reprints and copies – even extracts – are only permitted with the consent of the manufacturer.

Contents

| | | | |
|---|-----------|---|-----------|
| 1 General Guidelines | 3 | 6.6.1 Permitted Motor Attachments/ Breakdown Torques | 31 |
| 1.1 Definition of Terms | 3 | 6.6.2 Permitted Outer Acceleration and Deceleration Torques on the Brake | 31 |
| 2 Safety | 4 | 6.6.3 Permitted Shaft Loads | 31 |
| 2.1 Safety and Guideline Signs | 4 | 7 Electrical Connection and Wiring | 32 |
| 2.2 General Guidelines | 4 | 7.1 Earthing Connection | 32 |
| 2.2.1 Personnel Requirements | 4 | 7.2 Fuse Element | 32 |
| 2.3 Intended Use | 5 | 7.3 Switching Behaviour | 32 |
| 2.4 Handling | 5 | 7.4 Switching Modes | 32 |
| 2.5 User-implemented Protective Measures | 5 | 7.4.2 Magnetic field removal | 33 |
| 2.6 Dimensioning Other Machine Elements | 5 | 7.5 Protection circuit | 34 |
| 3 Legal Provisions | 6 | 8 Functional Safety Parameters | 35 |
| 3.1 Directives, Standards and Regulations Used | 6 | 8.1.1 Definition | 35 |
| 3.2 Liability | 6 | 8.1.2 Functional Safety Guidelines | 35 |
| 3.3 Guarantee | 6 | 8.1.3 Condition | 36 |
| 3.4 Guidelines on CE Identification | 7 | 9 Storage | 36 |
| 3.5 CE Identification | 7 | 9.1 Brake Storage | 36 |
| 3.6 Certification Symbols | 7 | 10 Installation | 37 |
| 3.7 Certification by the DGUV (German Social Accident Insurance) | 8 | 10.1 Mounting Conditions | 37 |
| 3.8 Identification/ Type tag | 8 | 10.2 Installation Conditions | 37 |
| 3.9 Existing Patents | 8 | 10.3 Brake Type 899.000.0_ | 38 |
| 4 Product Description | 9 | 10.4 Brake Type 899.001._ _ | 39 |
| 4.1 Scope of Delivery / State of Delivery | 9 | 10.5 Brake Type 899.002._ _ | 40 |
| 4.2 Function | 9 | 10.6 Brake Type 899.011._ _ | 41 |
| 4.2.1 Quiescent Current Principle | 9 | 10.7 Brake Type 899.012._ _ | 42 |
| 4.2.2 Reliable Braking Function | 9 | 10.8 Brake Type 899.100.0 _ | 43 |
| 4.2.3 Release monitoring | 10 | 10.9 Brake Type 899.111._ _ | 44 |
| 4.3 Designs | 11 | 10.10 Brake Type 899.112._ _ | 45 |
| 4.4 Parts List | 12 | 10.11 Electrical connection in the terminal Box | 46 |
| 4.5 Dimensions and Tightening Torques | 13 | 10.11.1 Release Monitoring / Proximity Switch | 46 |
| 4.6 Further Designs | 14 | 10.11.2 Release Monitoring / Microswitch | 46 |
| 4.6.1 Shaft with Key | 14 | 10.12 Release monitoring | 47 |
| 4.6.2 Extended Protection IP 65 | 14 | 10.12.1 General | 47 |
| 4.6.3 Hand Release | 14 | 10.12.2 Release Monitoring with Proximity Switch | 48 |
| 5 Technical Data | 15 | 10.12.3 Release Monitoring with Microswitch | 49 |
| 5.1 Guidelines | 15 | 11 Initial Operation | 50 |
| 5.1.1 Application Conditions | 15 | 11.1 Function Test | 50 |
| 5.1.2 Ambient Temperature | 15 | 11.2 Brake Test (Static) | 50 |
| 5.1.3 Class of Insulation F (+155 °C) | 15 | 11.3 Brake Test (Dynamic) | 50 |
| 5.1.4 Protection | 15 | 12 Maintenance/Inspections | 51 |
| 5.1.5 Noise Emissions | 15 | 13 Information on the Components | 52 |
| 5.2 Technical Data | 16 | 13.1 Protective measures and rules of behaviour: | 52 |
| 5.2.1 Type 899.000.0_ | 16 | 14 Cleaning the Brake | 52 |
| 5.2.2 Type 899.00._ _ | 18 | 15 Wear Inspection | 53 |
| 5.2.3 Type 899.01._ _ | 20 | 16 De-installation | 54 |
| 5.2.4 Type 899.11._ _ | 23 | 17 Disposal | 54 |
| 5.3 Switching Times | 26 | 18 Malfunctions / Breakdowns | 55 |
| 5.4 Friction Power / Friction Work | 28 | 19 Declaration of Conformity | 57 |
| 6 Intended Use | 29 | | |
| 6.1 Guidelines for Application | 29 | | |
| 6.2 Limits | 29 | | |
| 6.3 Reasonably Foreseeable Misuse | 29 | | |
| 6.4 Duration of Use | 29 | | |
| 6.5 Brake Dimensioning | 30 | | |
| 6.6 Outer Parameters | 31 | | |

Please read these Operational Instructions carefully and follow them accordingly!

Ignoring these Instructions may lead to malfunctions or to brake failure, resulting in damage to other parts. These Operational Instructions are part of the brake delivery.
Please keep them handy and near to the brake at all times.





1 General Guidelines

1.1 Definition of Terms

| Term | Meaning |
|--|---|
| ROBA®-topstop® | Electromagnetically-actuated safety brakes as a component for holding and deceleration of moved machine parts. |
| Braking torque M_N Standard | The theoretical nominal braking torque assigned to the designation. The braking torque lies within the stated braking torque tolerances. The braking torque tolerance is stated in % of the braking torque Standard. |
| Braking torque M_N Increased | Extended design with a maximum theoretical nominal braking torque which can only be operated with an overexcitation circuit for the magnetic coil. The braking torque tolerance is stated in % of the braking torque Increased. |
| Load torque | Holding torque which is required to hold a vertical axis (load) suspended, referring to the brake. |
| Release (separate) | Release designates the procedure through which the magnetic coil is energised, the rotor is released in the brake, and therefore no braking torque is applied. |
| Close (connect) | Closing or armature disk drop-out designates the process through which the magnetic coil is de-energised, the voltage is switched off, the rotor in the brake is clamped and the braking torque is applied. |
| Overexcitation | Overexcitation designates when the brake requires a higher supply voltage (= overexcitation voltage) than the coil nominal voltage to release for a short period of time (overexcitation time). Here a ratio of 2:1 or 3:1 is usual. |
| Overexcitation time | The overexcitation voltage must only be available for a short time for release of the brake. This time from 150ms to 2 s is dependent on the brake size. |
| Holding voltage | The voltage at which the brake remains permanently released. Usually, this is also the coil nominal voltage for brakes which are not overexcited. |
| Response delay on connection t_{11} (close) | The time from power switch-off to the start of the braking torque increase (10 % of the stated braking torque). |
| Connection time t_1 (drop-out time) | The time from power switch-off to achieving 90 % of the stated braking torque. |
| Separation time t_2 (attraction time) (release) | The time from power switch-on to achieving 10 % of the stated braking torque. At this point, the brake is almost free. |
| AC-side switching or switching with freewheeling diode | The power circuit is interrupted in front of the rectifier or in front of a freewheeling diode, which is connected parallel to the magnetic coil. The magnetic field slowly reduces and thus causes a substantially longer connection time t_1 . The braking torque is available after a long delay. |
| DC-side switching | The power circuit is interrupted between the rectifier / the DC power supply and the coil as well as mains-side. The magnetic field reduces extremely quickly and the braking torque quickly becomes available. |
| Switching distance S_n (proximity switch) | The rated switching distance stated by the manufacturer at which a signal change takes place under standard conditions. |
| Varistor (or similar components) | With DC-side switching, the inductive switch-off voltage peaks are to be limited in accordance with VDE 0580. To do this, the installation of voltage-limiting components must be provided. One possibility is protection through a spark quenching unit by mayr® or using a suitable varistor (see www.mayr.com). |
| Overtravel time/ overtravel path | Temporal duration of the overtravel (= The path of potentially dangerous movement conducted after switch-off) |

2 Safety

2.1 Safety and Guideline Signs

| Symbol | Signal word | Meaning |
|---|-----------------------|--|
|  | DANGER | Designates a directly pending danger. If not avoided, death or severe injuries will be the consequence. |
|  | WARNING | Designates a possibly hazardous situation. If not avoided, death or severe injuries will be the consequence. |
|  | CAUTION | Designates a hazardous situation. If not avoided, slight or minor injuries can be the consequence. |
| | ATTENTION | Possible property damage can be the consequence. |
|  | Please Observe | Designates tips for application and other particularly useful information. Not a signal word for dangerous or damaging situations. |





2.2 General Guidelines

DANGER



Danger of death! Do not touch voltage-carrying lines and components.

Brakes may generate further risks, among other things:

| | | | |
|---|---|---|---|
|  |  |  |  |
| Hand injuries | Danger of seizure | Contact with hot surfaces | Magnetic fields |

Severe injury to people and damage to objects may result if:

- the electromagnetic brake is used incorrectly.
- the electromagnetic brake is modified.
- the relevant standards for safety and / or installation conditions are ignored.

2.2.1 Personnel Requirements

To prevent injury or damage, only professionals and specialists are allowed to work on the components.

They must be familiar with the dimensioning, transport, installation, initial operation, maintenance and disposal according to the relevant standards and regulations.

 Before product installation and initial operation, please read the Installation and Operational Instructions carefully and observe the Safety Regulations. Incorrect operation can cause injury or damage.

- Technical data and specifications (Type tags and documentation) must be followed.
- The correct connection voltage must be connected according to the Type tag and wiring guidelines.
- Check electrical components for signs of damage before putting them into operation. Never bring them into contact with water or other fluids.
- Please observe the EN 60204-1 requirements for electrical connection when using in machines.

 Only carry out installation, maintenance and repairs when the brake is in a de-energised, disengaged condition and secure the system against inadvertent switch-on (acc. EN 50110).

General Guideline:

During the risk assessment required when designing the machine or system, the dangers involved must be evaluated and removed by taking appropriate protective measures in accordance with the Machinery Directive 2006/42/EC.

Brakes for safety-related applications are to be installed singly or as redundant devices in accordance with the required category, in order to fulfil the required Performance Level (PL_r) acc. EN ISO 13849. This is in principle the task of the system manufacturer.

2.3 Intended Use



Use according to the intended purpose is prohibited until it has been determined that the machine / system accords with the EC Directive 2006/42/EC (machinery directive).

mayr®-brakes have been developed, manufactured and tested in compliance with the DIN VDE 0580 standard and in accordance with the EU machinery directive as electromagnetic components. During installation, operation and maintenance of the product, the requirements for the standard must be observed.

ROBA®-topstop® brakes by mayr® prevent inadvertent dropping or crashing of gravity-loaded axes.

- ROBA®-topstop® brakes are intended for use in industrial machines and systems with electrical drives.
- For applications in, for example, defence technology or medical products, **please contact mayr®**.
- Not suitable for operation in areas where there is a danger of explosion
- Not suitable for applications with combustion engines

The brakes must only be used in the situations for which they are ordered and confirmed. Using them for any other purpose is not allowed.

2.4 Handling

Before installation, the brake must be inspected and found to be in proper condition (visual inspection). The following are not considered as being representative of a proper condition:

- Outer damage
- Outer oiling
- Outer contamination

The brake function must be inspected both **once attachment has taken place** as well as **after longer system downtimes**, in order to prevent the drive starting up against possibly seized linings.

Possible inspection:

- In released condition, the rotor (shaft) must be freely rotatable

2.5 User-implemented Protective Measures

- Attach a cover to protect **against injury through high temperatures** on the housing if high temperatures are conducted for example by the drive motor into the brake housing, thus generating increased temperatures >60 °C on the brake housing (**see section 5.1.1**).
- Protection circuit: see section 7.5**
- Switching times:
DC-side switching is required for fast switching, short connection times and short braking distances. Every further installation of protective elements delays the switching time and therefore also the braking distance.
See section **7** Connection and Wiring
- Install additional protective measures **against corrosion** if the brake is subject to extreme ambient conditions or is installed in open air conditions, unprotected from the weather.
- Take precautions **against freeze-up of the friction surfaces** in high humidity and at low temperatures.
► **Please contact mayr®**.

2.6 Dimensioning Other Machine Elements

The effects of the maximum braking torques on the other machine components must be observed in order to provide sufficient dimensioning.

If more brake components are required, the brake forces may add up depending on the brake layout on the appropriate components.

3 Legal Provisions

3.1 Directives, Standards and Regulations Used

(also to be observed during installation and operation)

| | |
|-----------------------|--|
| 2006/42/EG | Machinery directive |
| 2014/35/EU | Low voltage directive |
| 2014/30/EU | EMC Directive |
| DIN VDE 0580 | Electromagnetic devices and components, general specifications |
| EN ISO 12100 | Safety of machinery - General principles for design - Risk assessment and risk reduction |
| EN ISO 13849-2 | Safety of machinery Safety related parts of control systems - Validation |
| DIN EN 61000-6-4 | Interference emission |
| DIN EN 61000-6-2 | Interference immunity |
| CSA C22.2 No. 14-2010 | Industrial Control Equip- |
| UL 508 (Edition 17) | Industrial Control Equip- |

3.2 Liability

The information, guidelines and technical data in these documents were up to date at the time of printing. Demands on previously delivered brakes are not valid. Liability for damage and operational malfunctions will not be taken if:

- the Installation and Operational Instructions are ignored or neglected,
- the brakes are used inappropriately.
- the brakes are modified,
- the brakes are worked on unprofessionally.
- the brakes are handled or operated incorrectly.

3.3 Guarantee

- The guarantee conditions correspond with the Chr. Mayr GmbH + Co. KG sales and delivery conditions (www.mayr.com → Service → General Terms and Conditions)
- Mistakes or deficiencies are to be reported to *mayr*® at once!

3.4 Guidelines on CE Identification



Guidelines on the Declaration of Conformity

A conformity evaluation has been carried out for the product (electromagnetic safety brake) in terms of the EU Low Voltage Directive 2014/35/EU. The Declaration of Conformity is laid out in writing in a separate document and can be requested if required.

Guidelines on the EMC Directive (2014/30/EU)

The product cannot be operated independently according to the EMC directive. Due to their passive state, brakes are also non-critical equipment according to the EMC. Only after integration of the product into an overall system can this be evaluated in terms of the EMC. For electronic equipment, the evaluation has been verified for the individual product in laboratory conditions, but not in the overall system.

Guidelines on the Machinery Directive (2006/42/EC)

The product is a component for installation into machines according to the Machinery Directive 2006/42/EC. The brakes can fulfil the specifications for safety-related applications in coordination with other elements. The type and scope of the required measures result from the machine risk analysis. The brake then becomes a machine component and the machine manufacturer assesses the conformity of the safety device to the directive.

It is forbidden to start use of the product until you have ensured that the machine accords with the regulations stated in the directive.

Guidelines on the EU Directive on the Restriction of the Use of Certain Hazardous Substances in Electrical and Electronic Equipment

The electromagnetic brake as well as the rectifiers / microswitches / proximity switches required for control / self-monitoring fulfil the requirements laid down in the EU Directive 2011/65/EC (RoHS). (Restrictions on the use of certain hazardous substances, such as lead (0.1 %), mercury (0.1 %), cadmium (0.01 %), hexavalent chromium (0.1 %), polybrominated biphenyls (PBB) (0.1 %), polybrominated diphenylethers (PBDE) (0.1 %))

Guidelines on the ATEX Directive



Without a conformity evaluation, this product is not suitable for use in areas where there is a high danger of explosion.

For application of this product in areas where there is a high danger of explosion, it must be classified and marked according to Directive 2014/34/EU.

3.5 CE Identification

| | |
|---|--|
|  | Identification according to the Machinery Directive 2006/42/EC |
|---|--|

3.6 Certification Symbols

| | |
|---|--|
|  | <p>Certificate: LR 108927-1</p> <p>The brakes are approved up to 300 V in accordance with the Canadian regulations "Canadian Standard Association" (CSA). The installation components used are UL-listed or are applied in conformance with the approval. The CSA conformity marking with the addition of "C" and "US" means that the product has been certified both for the US American market as well as for the Canadian market, and accords with the applicable US American and Canadian standards.</p> |
|  | <p>DGUV (German Social Accident Insurance) test certificate "Braking device as tried and tested component in terms of the Category 1 acc. DIN EN ISO 13849-1"</p> <p>Product name: ROBA®-topstop® single circuit brake typ: 200/899.012.22</p> |

3.7 Certification by the DGUV (German Social Accident Insurance)

In order to inspect their safety characteristics, some of our ROBA®-topstop® brakes were presented to the Employer's Liability Insurance Association (DGUV test) for inspection and certification. The test and certification bodies of the Employer's Liability Insurance are recognised in accordance with the Product Safety Act, and have been designated "Notified Bodies" by the EU Commission. The inspections take place in accordance with the basic inspection principles available to the Employer's Liability Insurance, under defined test conditions. Due to the numerous products and designs available on the market, the inspections are limited to certain characteristics important for machine work safety, for example reliable holding (suspension) of vertical axes and/or reliable emergency braking characteristics. The inspections do not therefore comprise of all our product characteristics and of all our product types. Please contact us to find out which product types and which characteristics of our ROBA®-topstop® have been inspected and certified. We are happy to send you the appropriate certification.



Test confirmation acc. DGUV (German Social Accident Insurance), in accordance with:
 PG I/2-49 "Principles of testing and certification of emergency brake systems with holding force function for linear movements" Issue 07.2010 (→GS-MF-28)
 See also the sector's Information Sheet "Gravity-loaded axes – (Vertical axes)" DGUV section 6 (**11.2.**)

3.8 Identification/ Type tag

mayr® components are clearly marked and described on the Type tag:

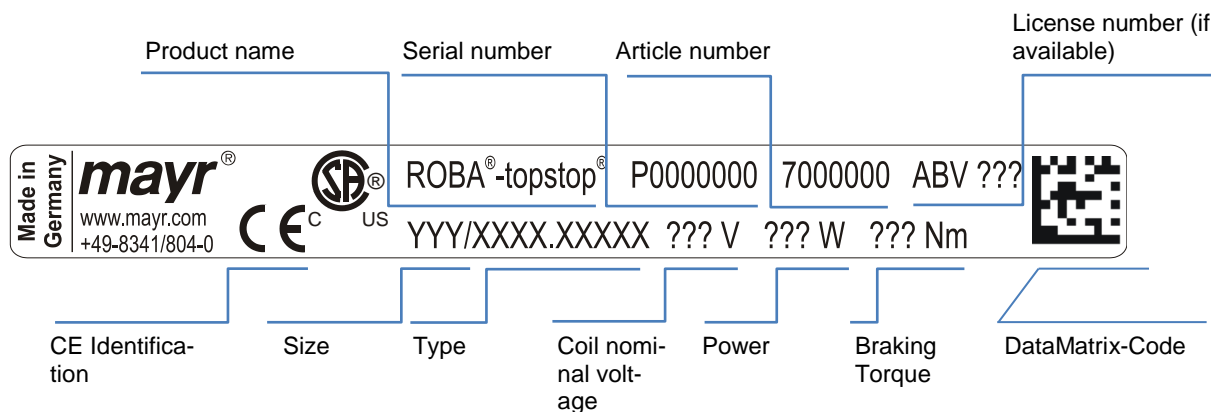

Serial number

| Year | Code |
|------|------|
| 2000 | A |
| 2001 | B |
| 2002 | C |
| 2003 | D |
| 2004 | E |
| 2005 | F |
| 2006 | H |
| 2007 | J |
| 2008 | K |
| 2009 | L |
| 2010 | M |
| 2011 | N |
| 2020 | A |

| Year | Code |
|------|------|
| 2012 | P |
| 2013 | R |
| 2014 | S |
| 2015 | T |
| 2016 | U |
| 2017 | V |
| 2018 | W |
| 2019 | X |
| | |
| | |
| | |
| | |

3.9 Existing Patents

Patent numbers EP 1 651 883 B1 and CN 101592202 B

4 Product Description

4.1 Scope of Delivery / State of Delivery

- ROBA®-topstop® brakes Type 899.000.0 are manufacturer-assembled ready for installation. Each cap screw (10) in the clamping ring (9) is aligned to the screw plug (16).
- The ROBA®-topstop® brakes Type 899.0_1._ _ and 899.0_2._ _ are manufacturer-assembled ready for installation on the output side; the respective shrink disk hubs (1) are centred and radially fixed via the rotor (22). The clamping hub (3) or shrink disk hub (5) are included loose in delivery.

ROBA®-topstop® brakes Type 899.1_ _ _ are pre-assembled. Included loose in delivery are:

- For Type 899.100.0 _ :
 - Rotor (22)
 - Shaft (7) with clamping screw (10)
- For Type 899.11 _ _ :
 - Rotor (22)
 - Shrink disk hubs (1) with cap screws (2)
 - Elastomeric element (11)
 - Clamping hub (3) with cap screw (4) or
 - Shrink disk hub (5) with cap screws (6).
- Please check the state of delivery immediately! *mayr*® will take no responsibility for belated complaints. Please report transport damage immediately to the supplier. Please report incomplete delivery and obvious defects immediately to the manufacturer.



Caution Please observe the own weight of the brake

The brake may drop during lifting / transport. The consequences may be crush injuries and impact injuries.

For Size 260, use an eyebolt for lifting aids.

In de-energised condition, several thrust springs press against an armature disk (21). The rotor (22) is clamped between the armature disk (21) and the flange (13) through mounted friction linings, and is braked. The rotor (22) is connected via positive locking with the shaft (7/8/32) or the shrink disk hub (1).

A magnetic force is generated in the coil carrier (20) through application of the coil nominal voltage. The armature disk (21) is attracted against the spring pressure to the coil carrier (20). The rotor becomes free and the brake is released. The shrink disk hub (1) or the shaft (7/8/32) can rotate freely.

4.2.2 Reliable Braking Function

The dimensioning of the thrust springs in the dynamic fatigue strength range avoids a loss of spring force over the lifetime of the brake.

The available braking torque does not reduce by more than 20 % even if a spring fails.

This is achieved through:

- The use of several thrust springs
- The use of thrust springs with a coil distance which is smaller than the wire diameter. In case of wire breakage, the coils cannot wind into each other. The pre-tension on the thrust spring does not reduce to an unpermitted extent and the braking torque remains guaranteed.

4.2 Function

4.2.1 Quiescent Current Principle

The function principle applied here accords with the application of the energy-separation principle in accordance with EN ISO 13849-2 Appendix A.2 "List of basic safety principles". The reliable condition is achieved through separation of the energy source, and thus accords with the required safety aspects, for example during power failure or EMERGENCY STOP.

4.2.3 Release monitoring

ROBA®-topstop® brakes are supplied as a standard product with manufacturer-side set release monitoring.

Functional Description:

The integrated release monitoring detects the armature disk position of either armature disk attracted (released) or dropped (closed), and emits a signal accordingly. From attracted to dropped condition, the armature disk carries out a path of approx. 0.4mm. In energised condition, the armature disk is attracted and lies against the coil carrier. The brake is free; the power circuit for the release monitoring is closed (NO function) and emits a signal. If the electromagnet is switched off, the thrust springs press the armature disk away from the coil carrier, against the rotor. The brake has its braking torque, and the release monitoring signal is switched off. Both inspections; the signal evaluation and the condition change, must take place customer-side. This prevents possible start-up of the motor against the closed brake and the resulting damage to the brake. A reliable start to the following program steps can take place.

The release monitoring is equipped with a proximity switch as a standard measure. Optionally, a microswitch design is also available (see section **10.12** release monitoring)

Signal evaluation:

After each energisation or de-energisation of the brake, a signal change of the release monitoring must take place within $3 \times t_1$ ($3 \times$ connection time) and $3 \times t_2$ ($3 \times$ separation time). If this plausibility is not fulfilled, an unpermitted condition has occurred.

WARNING Load crash possible



The brake may not have built up a braking torque.

If no signal change occurs on brake de-energisation after $3 \times t_1$, a dangerous failure may have occurred.

A machine-side malfunction message must occur in order to achieve a safe condition.

4.3 Designs

Output side ← Input side
Machine side ← Motor side

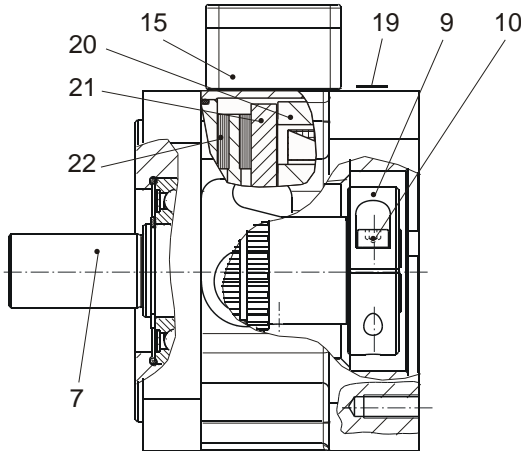

Fig. 1: Type 899.000.0

Output side ← Input side
Machine side ← Motor side

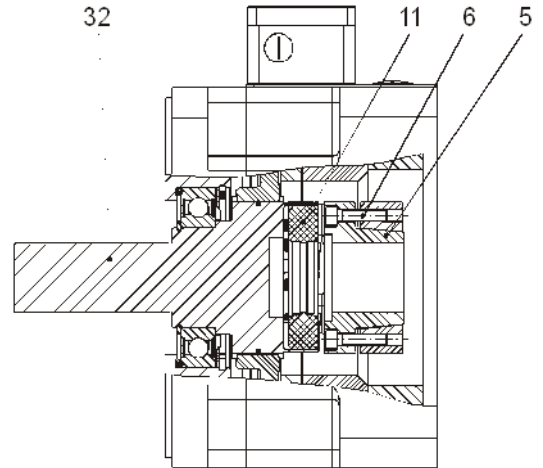

Fig. 2: Type 899.002.

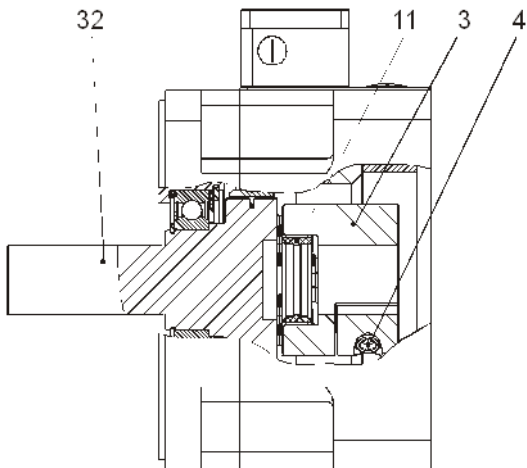

Fig. 3: Type 899.001.

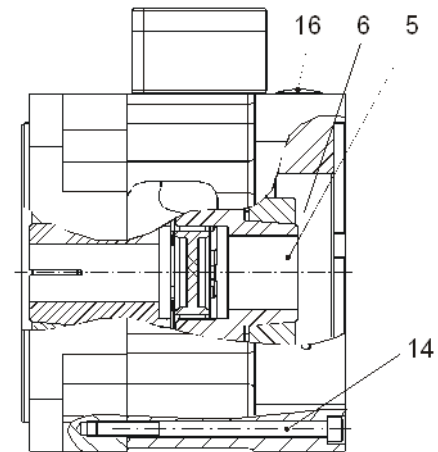

Fig. 4: Type 899.012.

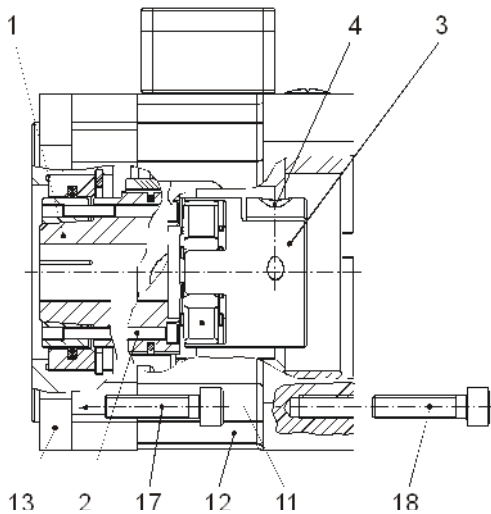

Fig. 5: Type 899.011.

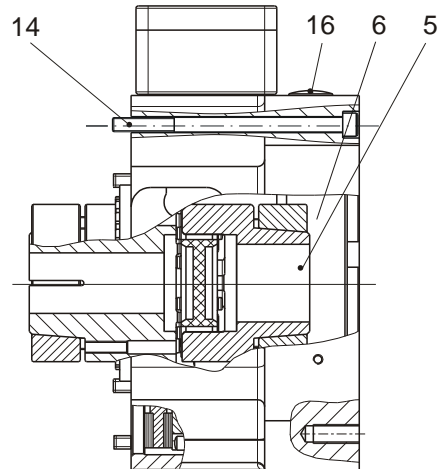

Fig. 4a: Type 899.112.

Operational Instructions for ROBA®-topstop® Type 899. _ _ _ . _ _ _ Sizes 100 - 260

(B.8.8.EN)

4.4 Parts List

(Only use *mayr*® original parts)

| Item | Name |
|------|--|
| 1 | Shrink disk hub assembly (output side) |
| 2 | Cap screw |
| 3 | Clamping hub |
| 4 | Cap screw |
| 5 | Shrink disk hub assembly (input side) |
| 6 | Cap screw |
| 7 | Shaft (Type 899.000.0_) |
| 8 | - |
| 9 | Clamping ring |
| 10 | Cap screw |
| 11 | Elastomeric element |
| 12 | Flange housing (input side) |
| 13 | Flange (output side) |
| 14 | Cap screw |
| 15 | Terminal box assembly |
| 16 | Screw plug |
| 17 | Cap screw (provided by the customer), property class 8.8 |
| 18 | Cap screw (provided by the customer), property class 8.8, minimal screw-in depth 1.5 x dimension "S ₁ " |
| 19 | Type tag |
| 20 | Coil carrier |
| 21 | Armature disk |
| 22 | Rotor |
| 23 | Threaded bolt (section 10.12.3) |
| 24 | Counter nut M5 (section 10.12.3) |
| 25 | Hexagon head screw M3 x 8 (section 10.12.3) |
| 26 | Counter nut M3 (section 10.12.3) |
| 27 | Microswitch assembly for release monitoring (section 10.12.3) |
| 28 | Proximity switch assembly for release monitoring (section 10.12.2) |
| 29 | Switching bolt (section 10.12.2) |
| 30 | Cap screw M5 x 30 (section 10.12.2) |
| 31 | Cap screw M4 x 8 (section 10.12.2) |
| 32 | Shaft (Types 899.001._ _ and 899.002._ _) |
| 33 | O-ring (section 4.6.2) |
| 34 | Flat seal (section 4.6.2) |
| 35 | Screw plug (section 15) |
| 36 | Friction flange (output side / customer-side) |

Operational Instructions for ROBA®-topstop® Type 899. _ _ _ . _ _ _ Sizes 100 - 260

(B.8.8.EN)

4.5 Dimensions and Tightening Torques

| ROBA®-topstop® brake | | Sizes | | | | | | |
|---|------|---------------------|-----------------------|-----------------------|-----------------------|-----------------------|------------------------|------------------------|
| | | 100 | 120 | 150 | 175 | 200 | 230 | 260 |
| Dimension z ₂ (tolerance -0.03) | | - | 5.5 | 5.5 | | 6 | 8 | 8 |
| Required shaft length (brake) "l ₂ " | [mm] | - | 25 – 52 | 30 – 60 | 35 – 75 | 35 – 75 | 40 – 80 | 40 – 80 |
| Required shaft length (motor) "l ₃ " | [mm] | - | 40 – 50 | 50 – 58 | 58 – 80 ¹⁾ | 58 – 80 ¹⁾ | 80 – 110 ³⁾ | 80 – 110 ²⁾ |
| Installation dimension (output) "W" | [mm] | - | 68 | 75.5 | 85 | 85 | 107 | 107 |
| Installation dimension (motor) "W ₁ " | [mm] | - | 36 | 42 | 52.5 | 52.5 | 52 | 52 |
| Installation dimension (motor) "W ₂ " | [mm] | - | 79 | 87.5 | 97.5 | 97.5 | - | 123 |
| Installation dimension (motor) "W ₃ " | [mm] | - | 16 | 18.5 | 22.5 | 22.5 | - | 26 |
| Installation dimension (motor) "Y" | [mm] | - | 5 | 6.5 | 10 | 10 | 10 | 10 |
| Installation dimension (motor) "Y ₁ " (=a ₁) | [mm] | - | 20 | 20.5 | 16 | 16 | 32 | 23 |
| Installation dimension (motor) "Y ₂ " | [mm] | - | 66 | 73 | 82 | 82 | - | 103.5 |
| Screw thread Items 2/6 | | - | M5 | M5 | M6 | M6 | M8 | M8 |
| Screw tightening torque Items 2/6 | [Nm] | - | 6 | 6 | 10 | 10 | 25 | 30 |
| Screw thread Item 4 | | - | M6 | M8 | M8 | M8 | M10 | M12 |
| Screw tightening torque Item 4 | [Nm] | - | 10 | 24 | 24 | 24 | 70 | 120 |
| Screw thread Item 10 | | M5 | M6 | M8 | M10 | M10 | M10 | M12 |
| Screw tightening torque Item 10 | [Nm] | 8.5 | 17 | 42 | 83 | 83 | 83 | 143 |
| Screw thread Item 14 | | M4 | M5 | M6 | M6 | M8 | M8 | M10 |
| Screw tightening torque Item 14 | [Nm] | 2.9 | 6 | 10 | 10 | 24 | 24 | 48 |
| Screw thread Items 17/18 | | M6/M8 ⁷⁾ | M8 | M10 | M12 | M12 | M12 | M16 |
| Screw tightening torque Items 17/18 | [Nm] | 10/24 ⁷⁾ | 24 | 48 | 83 | 83 | 83 | 200 |
| Rotor thickness in new condition | [mm] | 7 ^{+0.05} | 10.5 ^{-0.05} | 11.5 ^{-0.05} | 15 ^{-0.05} | 15 ^{-0.05} | 16 ^{-0.05} | 16 ^{-0.05} |
| Thread Ø "s ₁ " | [mm] | M6/M8 ⁷⁾ | M8 | M10 | M12 | M12 | M12 | M16 |
| Threaded hole depth "b" ⁵⁾ | [mm] | 12/15 ⁷⁾ | 20 | 24 | 25 | 28 | 28 | 30 |
| Max. permitted air gap dimension X ^{5) 6)} | [mm] | 0.5 | 0.55 | 0.6 | 0.6 | 0.6 | 0.6 | 0.65 |
| Max. permitted pull-in voltage ⁶⁾ at room temperature in % of the coil nominal voltage / over-excitation voltage | | 80 | 80 | 80 | 80 | 80 | 80 | 80 |

¹⁾ At a shaft length of more than 60 mm, only possible with a bored elastomeric element (11), for a max. shaft diameter of 38 mm

²⁾ At a shaft length of more than 85 mm, only possible with a bored elastomeric element (11), for a max. shaft diameter of 48 mm

³⁾ At a shaft length of more than 85 mm, only possible with a bored elastomeric element (11), for a max. shaft diameter of 42 mm

⁴⁾ Please **observe!!** Minimal screw-in depth 1.5 x dimension "s₁"

⁵⁾ Dimension X is the air gap between the rotor (22) and the armature disk (21) on an energised brake (section **15**)

⁶⁾ The information applies for the braking torque Standard as well as for the braking torque Increased (Type 899. _ _ _ . 1 / 899. _ _ _ . 2)

⁷⁾ Dependent on the screw-on pitch circle and centering (see **5.2** Technical Data)

4.6 Further Designs

4.6.1 Shaft with Key

For a positive-locking connection (see section [8.1.2](#))

4.6.2 Extended Protection IP 65

The extended Protection IP65 can be retrofitted on all standard brakes. Design with hand release [4.6.3](#) only with protection IP54 possible.

The set of seals provides an improved sealing performance from the mounting side (machine) to the brake through an NBR O-ring (33) in the flange (13) of the brake, and, from the brake to the motor through an NBR flat seal (34) or an NBR O-ring.

The penetration of dirt from the input side (machine side) via the shaft cannot be ruled out.



Wear of the set of seals due to repeated assembly / disassembly of:

- The brake
- The motor onto/from the brake
- ▶ Use a new set of seals.

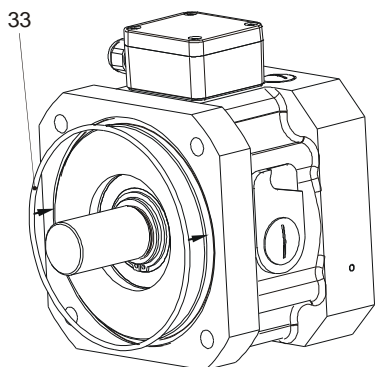

Fig. 6 Output-side seal

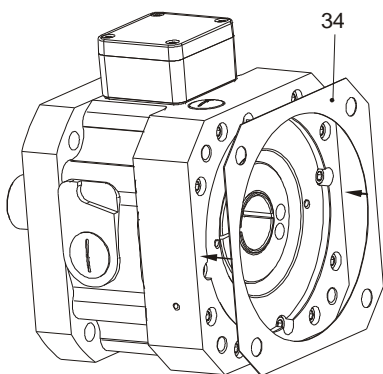

Fig. 7: Input-side seal



With Sizes 100/175, the input-side sealing is also conducted using an NBR O-ring in contrast to the other sizes.

4.6.3 Hand Release



The hand release is optional and must be ordered with the brake. The hand release is installed and set manufacturer-side. Only with protection IP54 possible.

The hand release is subject to wear and is not suitable for constant release.

A sufficient quantity of emergency releases is possible (approx. 1000x).

WARNING

Load crash possible



The braking torque on the brake is nullified on actuation of the hand release.

When actuating the hand release, the axis / load must be supported.

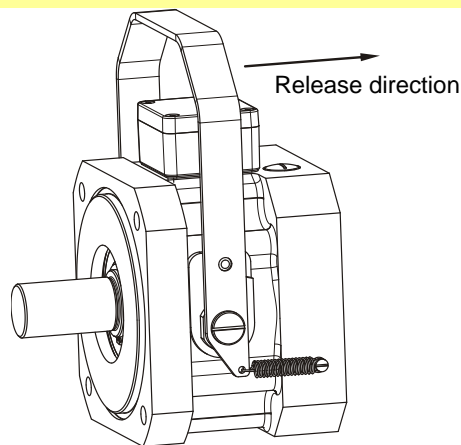

Fig. 8: Brake not released (ready for operation)

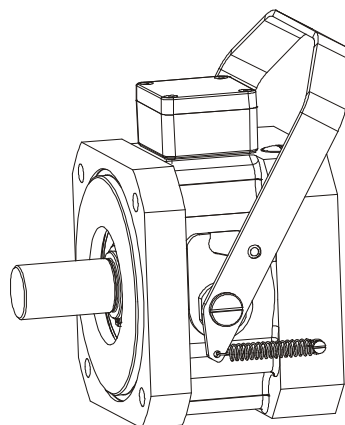

Fig. 9: Brake released (not ready for operation)

5 Technical Data

5.1 Guidelines

5.1.1 Application Conditions



The stated values are guideline values which have been determined in test facilities. It may be necessary to carry out your own tests for the intended application. When dimensioning the brakes, please remember that installation situations, braking torque fluctuations, permitted friction work, run-in behaviour and wear as well as general ambient conditions can all affect the given values. These factors should therefore be carefully assessed, and alignments made accordingly.

- ❑ Mounting dimensions and connection dimensions must be adjusted according to the size of the brake at the place of installation.
- ❑ The magnetic coils are designed for a relative duty cycle of 100%.
- ❑ Temperatures of up to 60 °C can occur on the brake housing at an ambient temperature of 40 °C.
In higher ambient temperatures, for example when mounted onto the drive motor, which can achieve temperatures of 80 °C to 100 °C during operation, the brake housing temperature will also increase. Protective measures must be undertaken customer-side against contact burns.
- ❑ The braking torque is dependent on the present run-in condition of the brake.
- ❑ The surfaces of the outer components have been phosphated manufacturer-side to form a basic corrosion protection. For brake applications outdoors where the device is subject to weather influences or extreme environmental conditions, additional protective measures, such as for example protective paint, must be provided.
- ❑ No axial backlash must be transmitted onto the brake customer-side (max. 0.05 mm).
Excessive axial backlash leads to particularly heavy wear on the rotor (22).

Attention The rotors may rust up and block in corrosive ambient conditions and/or after long periods of storage. The user is responsible for taking appropriate countermeasures.
▶ Please contact *mayr*®.

5.1.2 Ambient Temperature

–20 ° up to +40 °C

The Technical Data refer to the stated temperature range.

Attention At temperatures of around or under freezing point, condensation can strongly reduce the torque or the rotors may freeze up. The user is responsible for taking appropriate countermeasures such as heating.

▶ Please contact *mayr*®.

5.1.3 Class of Insulation F (+155 °C)

The insulation components on the magnetic coils are manufactured at least to class of insulation F (+155 °C).

5.1.4 Protection

(mechanical) IP54: When installed, dust-proof and protected against contact as well as against water spray from any direction (dependent on customer-side mounting method).

Optional IP65 (see section [4.6.2](#))

(electrical) IP54: Dust-proof and protected against contact as well as against water spray from any direction.

5.1.5 Noise Emissions

The ROBA®-topstop® is not noise-reduced. When the armature disk is switched, the impact pulse from the armature disk onto the coil carrier or the armature disk onto the rotor generates a switching noise which can reach approx. 90 dB(A). The brake is not suitable for use in noise-sensitive applications.

5.2 Technical Data

5.2.1 Type 899.000.0_

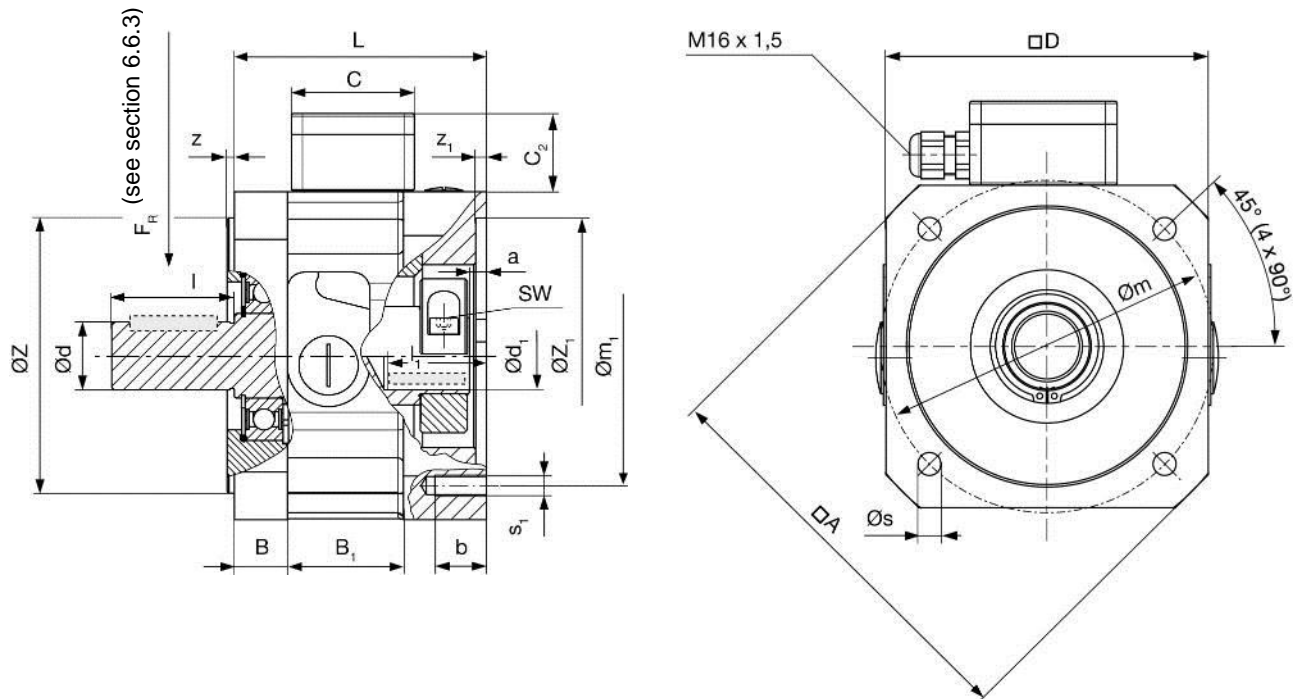

Fig. 10 Type 899.000.0_

Single circuit brake with bearing-supported clamping hub shaft

Operational Instructions for ROBA®-topstop® Type 899. _ _ _ . _ _ _ Sizes 100 - 260

(B.8.8.EN)

| Technical Data | | | | Size | | | | | | |
|--|-------------------------------|----------------------------------|--------------------------|------------|------------|----------|----------|-----------|-----------|-----------|
| | | | | 100 | 120 | 150 | 175 | 200 | 230 | 260 |
| Braking torque ¹⁾ | Type 899.000.01 | Standard | [Nm] | 6 | 12 | 45 | 70 | 100 | 150 | 200 |
| | | Braking torque range -20% / +40% | [Nm] | 4.8 / 8.4 | 9.6 / 16.8 | 36 / 63 | 56 / 98 | 80 / 140 | 120 / 210 | 160 / 280 |
| M _N | Type 899.000.02 ⁴⁾ | Increased | [Nm] | 12 | 30 | 90 | 120 | 160 | 300 | 400 |
| | | Braking torque range -20% / +40% | [Nm] | 9.6 / 16.8 | 24 / 42 | 72 / 126 | 96 / 168 | 128 / 224 | 240 / 420 | 320 / 560 |
| Electrical power | Type 899.000.01 | P _N | [W] | 21 | 31.5 | 44 | 50 | 60 | 86 | 86 |
| | Type 899.000.02 | P _O ²⁾ | [W] | 66 | 102 | 128 | 128 | 148 | 200 | 200 |
| | | P _H ³⁾ | [W] | 16 | 26 | 32 | 32 | 38 | 50 | 50 |
| Maximum speed | Type 899.000.0_ | n _{max} | [rpm] | 6000 | 5000 | 4000 | 4000 | 3000 | 3000 | 3000 |
| Weight | Type 899.000.0_ | m | [kg] | 4.75 | 7.5 | 13 | 20 | 24 | 45 | 60 |
| Mass Moment of Inertia Rotor + hub with d _{max} | Type 899.000.0_ | J _{R+N} | [10-4 kgm ²] | 0.9 | 6.5 | 16 | 43 | 52 | 131 | 250 |

| Dimensions | Size | | | | | | |
|--|------------------|--------------|----------------|----------------|----------------|----------------|----------------|
| | 100 | 120 | 150 | 175 | 200 | 230 | 260 |
| A | 130 | 160 | 190 | 232 | 246 | 305 | 345 |
| a | 4 | 5 | 6.5 | 10 | 10 | 10 | 10 |
| B | 15 | 20 | 25 | 20 | 20 | 25 | 25 |
| B1 | 42 | 52 | 55 | 90 | 71 | 52 | 92 |
| b | 12 | 20 | 24 | 25 | 28 | 30 | 30 |
| C | 58 | 58 | 58 | 58 | 58 | 75 | 75 |
| C2 | 37 | 37 | 37 | 37 | 37 | 56 | 56 |
| D | 100 | 126 | 155 | 176 | 194 | 235 | 264 |
| L | 80 | 104 | 119 | 138.5 | 138.5 | 185 | 185 |
| Shaft Ø d _{k6} x l | 14 x 30 | 19 x 40 | 24 x 50 | 35 x 79 | 32 x 58 | 38 x 80 | 48 x 82 |
| | 19 x 40 | 24 x 50 | 32 x 58 | - | 38 x 80 | 42 x 110 | 42 x 110 |
| | - | - | - | - | - | 48 x 110 | 48 x 110 |
| | - | - | - | - | - | - | 55 x 110 |
| Bohrungen ⁵⁾ Ø d ₁ ^{F7} x l ₁ | 14 x 45 | 19 x 55 | 24 x 68 | 35 x 90 | 32 x 90 | - | 42 x 110 |
| | 19 x 45 | 24 x 55 | 32 x 68 | - | 38 x 90 | - | 48 x 110 |
| | - | - | - | - | - | - | 55 x 110 |
| m | 100/115 | 130 | 165 | 200 | 215 | 265 | 300 |
| m1 | 100/115 | 130 (115*) | 165 | 200 | 215 | 265 | 300 |
| s | 7/9 | 9 | 11 | 13.5 | 13.5 | 14.5 | 18 |
| s1 | 4 x M6 4 x M8 | 4 x M8 M8 | 4 x M10 M10 | 4 x M12 M12 | 4 x M12 M12 | 4 x M12 M12 | 4 x M16 M16 |
| SW | 4 | 5 | 6 | 8 | 8 | 8 | 10 |
| Zj6 | 80 | 110 | 130 | 114.3 | 180 | 230 | 250 |
| | 95 | 95 | 110 | - | 130 | - | - |
| Z1 ^{F8} | 80 | 110 | 130 | 114.3 | 180 | 230 | 250 |
| | 95 | 95 | 110 | - | 130 | - | - |
| z | 3 | 3 | 3.5 | 3.5 | 4 | 5 | 5 |
| z1 | 4 | 5 | 5 | 10 | 6 | 10 | 10 |

| Preferred Bore | d1 | Size | | | | | | | |
|---|------------------------|------|-----|-----|-----|-----|-----|-----|-----|
| | | 100 | 120 | 150 | 175 | 200 | 230 | 260 | |
| Frictionally-locking transmittable torques (clamping hub motor-side) Suitable for F7/k6 | T _R [Nm] | Ø 14 | 30 | - | - | - | - | - | - |
| | | Ø 19 | 40 | 64 | - | - | - | - | - |
| | | Ø 24 | - | 81 | 150 | - | - | - | - |
| | | Ø 32 | - | - | 199 | - | 199 | - | - |
| | | Ø 35 | - | - | - | 215 | - | - | - |
| | | Ø 38 | - | - | - | - | 237 | 380 | - |
| | | Ø 42 | - | - | - | - | - | 440 | 545 |
| | | Ø 48 | - | - | - | - | - | 530 | 670 |
| | | Ø 55 | - | - | - | - | - | - | 845 |

Correlation of bore diameters d₁, dependent on respective transmittable torques (without key).
The transmittable torques for the clamping connection allow for the max. tolerance backlash on a solid shaft: Tolerance k6 / bore (d₁): tolerance F7. If the tolerance backlash is larger, the torque decreases.

- 1) Braking torque tolerance: -20 % / +40 %
- 2) Coil capacity on overexcitation
- 3) Coil capacity at holding voltage
- 4) Braking torque Increased only with overexcitation (see **7.4.1.3**)
- 5) The transmittable torques in bore d₁ are dependent on the diameter.
- *) Optionally available with pitch circle m₁ = 115

We reserve the right to make dimensional and constructional alterations.

5.2.2 Type 899.00. . . .

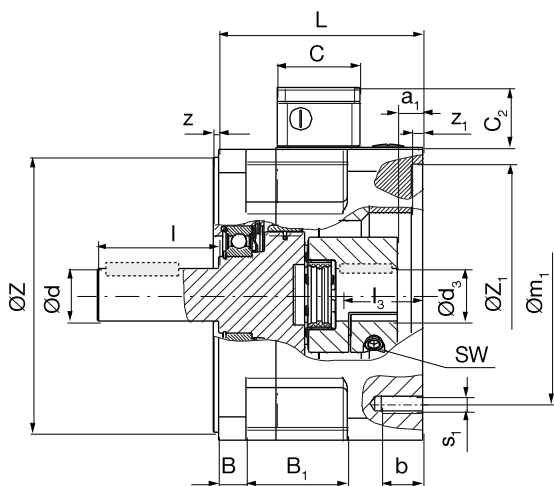

Fig. 11 Type 899.001. . . .

Single circuit brake with bearing-supported output shaft and with plug-in shaft coupling (clamping hub motor-side)

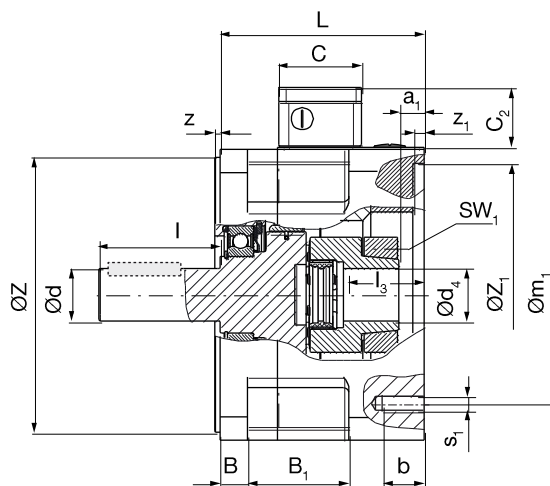

Fig. 12 Type 899.002. . . .

Single circuit brake with bearing-supported output shaft and with plug-in shaft coupling (shrink disk hub motor-side)

Operational Instructions for ROBA®-topstop® Type 899. _ _ _ . _ _ _ Sizes 100 - 260

(B.8.8.EN)

| Technical Data | | | | Size | | | | | |
|------------------------------|-------------------------------|----------------------------------|-------|------------|----------|----------|-----------|-----------|-----------|
| | | | | 120 | 150 | 175 | 200 | 230 | 260 |
| Braking torque ¹⁾ | Type 899.00._.1 | Standard | [Nm] | 12 | 45 | 70 | 100 | 150 | 200 |
| | | Braking torque range -20% / +40% | [Nm] | 9.6 / 16.8 | 36 / 63 | 56 / 98 | 80 / 140 | 120 / 210 | 160 / 280 |
| | Type 899.00._.2 ⁴⁾ | Increased | [Nm] | 30 | 90 | 120 | 160 | 300 | 400 |
| | | Braking torque range -20% / +40% | [Nm] | 24 / 42 | 72 / 126 | 96 / 168 | 128 / 224 | 240 / 420 | 320 / 560 |
| Electrical power | Type 899.00._.1 | P _N | [W] | 31.5 | 44 | 50 | 60 | 86 | 86 |
| | Type 899.00._.2 | P _O ²⁾ | [W] | 102 | 128 | 128 | 148 | 200 | 200 |
| | | P _H ³⁾ | [W] | 26 | 32 | 32 | 38 | 50 | 50 |
| Maximum speed | Type 899.00._. _ | n _{max} | [rpm] | 5000 | 4000 | 4000 | 3000 | 3000 | 3000 |

| Size of Flexible Coupling ⁵⁾ (ROBA®-ES) | | | [-] | 24 | 28 | 38 | 38 | 42 | 48 |
|--|---------------------------------|-------------------------------------|--------------------------|----------|-----------|-----------|-----------|----------|------------|
| Nominal and maximum torques, flexible coupling ⁵⁾ | Type 899.00._.3_ 92 Sh A | T _{KN} / T _{Kmax} | [Nm] | 35 / 70 | 95 / 190 | 190 / 380 | 190 / 380 | 265/530 | 310 / 620 |
| | Type 899.00._.2_ 98 Sh A | | [Nm] | 60 / 120 | 160 / 320 | 325 / 650 | 325 / 650 | 450/900 | 525 / 1050 |
| | Type 899.00._.1_ 64 Sh D | | [Nm] | 75 / 150 | 200 / 400 | 405 / 810 | 405 / 810 | 560/1120 | 655 / 1310 |
| Weight | Type 899.00._. _ | m | [kg] | 8.5 | 15 | 23 | 28 | 45 | 60 |
| Mass Moment of Inertia Rotor + hub with d _{max} | Type 899.001._. _ | J _{R+N} | [10-4 kgm ²] | 7.5 | 18.5 | 60 | 67 | 137 | 235 |
| | Type 899.002._. _ | | 8.5 | 21.5 | 70 | 77 | 151 | 250 | |

| Dimensions | Size | | | | | |
|--|-------------|---------|---------|---------|----------|-----------|
| | 120 | 150 | 175 | 200 | 230 | 260 |
| A ⁷⁾ | 160 | 190 | 232 | 246 | 305 | 345 |
| a1 | 20 | 20.5 | 16 | 16 | 32 | 23 |
| B | 20 | 25 | 20 | 20 | 25 | 25 |
| B1 | 52 | 55 | 90 | 71 | 92 | 92 |
| b | 20 | 24 | 25 | 28 | 30 | 30 |
| C | 58 | 58 | 58 | 58 | 75 | 75 |
| C2 | 37 | 37 | 37 | 37 | 56 | 56 |
| D ⁷⁾ | 126 | 155 | 176 | 194 | 235 | 264 |
| L | 104 | 119 | 138.5 | 138.5 | 185 | 185 |
| Shaft Ø d _{k6} x l | 19 x 40 | 24 x 50 | 35 x 79 | 32 x 58 | 38 x 80 | 48 x 82 |
| | 24 x 50 | 32 x 58 | - | 38 x 80 | 42 x 110 | 42 x 110 |
| | - | - | - | - | 48 x 110 | 48 x 110 |
| | - | - | - | - | - | 55 x 110 |
| Bores Ø d ₃ ^{F7} ⁶⁾ Ø d ₄ ^{H7} | 15-28 | 19-35 | 20-45* | 20-45* | 28-50 | 35-55* |
| | 15-28 | 19-38 | 20-45* | 20-45* | 28-50 | 35-60* |
| Required shaft length l ₃ | 40-50 | 50-58 | 58-80* | 58-80* | 80 - 110 | 80 - 110* |
| m ⁷⁾ | 130 | 165 | 200 | 215 | 265 | 300 |
| m1 | 130 (115**) | 165 | 200 | 215 | 265 | 300 |
| s ⁷⁾ | 9 | 11 | 13.5 | 13.5 | 13.5 | 18 |
| s1 | 4xM8 | 4xM10 | 4xM12 | 4xM12 | 4xM12 | 4xM16 |
| SW | 5 | 6 | 6 | 6 | 8 | 10 |

| Dimensions | Size | | | | | |
|------------------|------|-----|-------|-----|-----|-----|
| | 120 | 150 | 175 | 200 | 230 | 260 |
| SW1 | 4 | 4 | 5 | 5 | 6 | 6 |
| Zj6 | 110 | 130 | 114.3 | 180 | 230 | 250 |
| | 95 | 110 | - | 130 | - | - |
| Z1 ^{F8} | 110 | 130 | 114.3 | 180 | 230 | 250 |
| | 95 | 110 | - | 130 | - | - |
| z | 3 | 3.5 | 3.5 | 4 | 5 | 5 |
| z1 | 5 | 5 | 10 | 6 | 10 | 10 |

- 1) Braking torque tolerance: -20 % / +40 %
- 2) Coil capacity on overexcitation
- 3) Coil capacity at holding voltage
- 4) Braking torque Increased only with overexcitation (see **7.4.1.3**)
- 5) For further information on flexible coupling e.g. angle misalignments, spring stiffness or temperature resistance please see ROBA®-ES catalogue [K.940.V._._](#)
- 6) The transmittable torques in bores d₃ and d₄ are dependent on the diameter, see tables "Preferred Bores" **5.2.3**.
- 7) See Dimensions Fig. on the right, Section **5.2.1**.
*) - Sizes 175 and 200: At a shaft length of more than 60 mm, only possible with a bored elastomeric element (max. through hole Ø38 mm)
- Size 260: At a shaft length of more than 85 mm, only possible with a bored elastomeric element (max. through hole Ø48 mm)
**) Optionally available with pitch circle m1 = 115

We reserve the right to make dimensional and constructional alterations.

5.2.3 Type 899.01. . . .

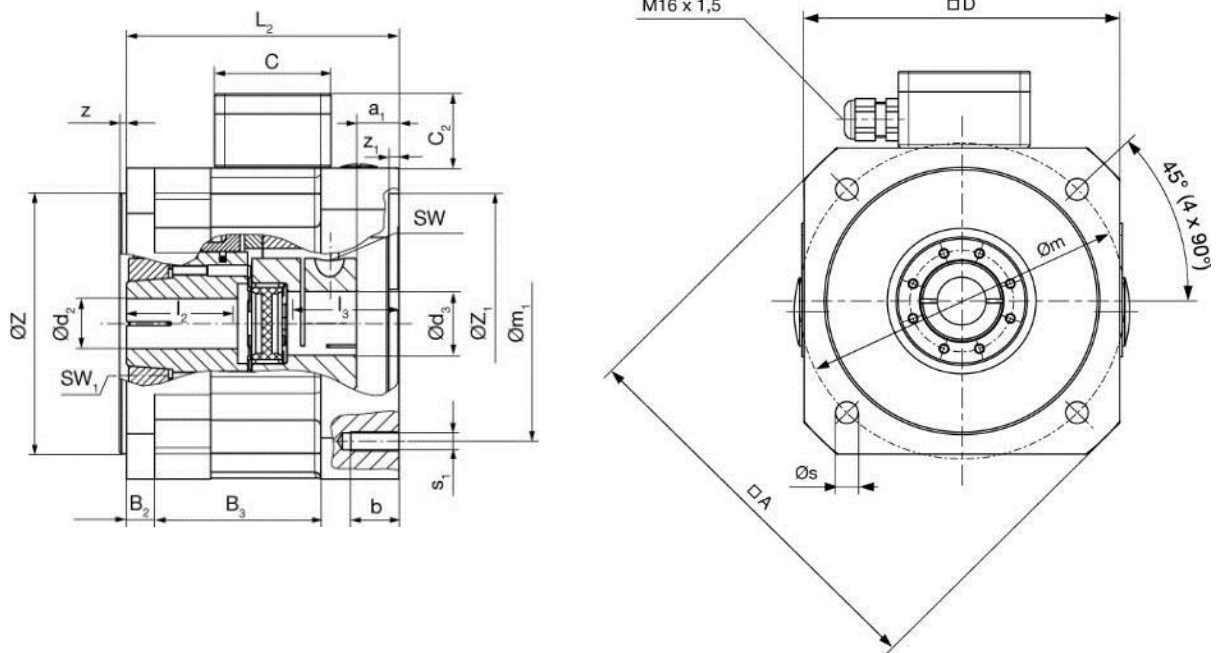

Fig. 13 Type 899.011. . . .
Single circuit brake with plug-in shaft coupling (clamping hub motor-side)

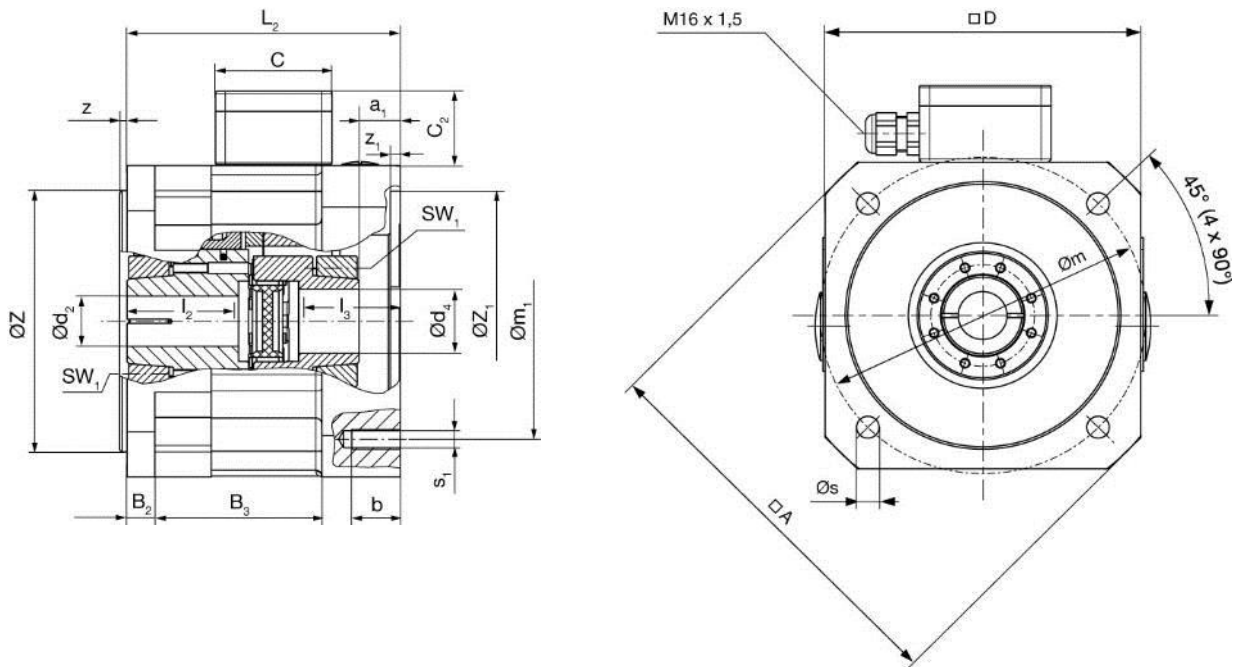

Fig. 14 Type 899.012. . . .
Single circuit brake with plug-in shaft coupling (shrink disk hub motor-side)

Operational Instructions for ROBA®-topstop® Type 899. _ _ _ . _ _ _ Sizes 100 - 260

(B.8.8.EN)

| Technical Data | | | | Size | | | | | |
|-------------------------------------|-------------------------------|-------------------------------------|-------|------------|----------|----------|-----------|-----------|-----------|
| | | | | 120 | 150 | 175 | 200 | 230 | 260 |
| Braking torque ¹⁾ | Type 899.01._.1 | Standard | [Nm] | 12 | 45 | 70 | 100 | 150 | 200 |
| | | Braking torque range -20% / +40% | [Nm] | 9.6 / 16.8 | 36 / 63 | 56 / 98 | 80 / 140 | 120 / 210 | 160 / 280 |
| | Type 899.01._.2 ⁴⁾ | Increased | [Nm] | 30 | 90 | 120 | 160 | 300 | 400 |
| | | Braking torque range -20% / +40% | [Nm] | 24 / 42 | 72 / 126 | 96 / 168 | 128 / 224 | 240 / 420 | 320 / 560 |
| Electrical power | Type 899.01._.1 | P _N | [W] | 31.5 | 44 | 50 | 60 | 86 | 86 |
| | Type 899.01._.2 | P _O ²⁾ | [W] | 102 | 128 | 128 | 148 | 200 | 200 |
| | | P _H ³⁾ | [W] | 26 | 32 | 32 | 38 | 50 | 50 |
| Maximum speed | Type 899.01._.1 | n _{max} | [rpm] | 5000 | 4000 | 4000 | 3000 | 3000 | 3000 |

| Size of Flexible Coupling ⁵⁾ (ROBA®-ES) | | | [-] | 24 | 28 | 38 | 38 | 42 | 48 |
|--|---------------------------------|-------------------------------------|--------------------------|----------|-----------|-----------|-----------|------------|------------|
| Nominal and maximum torques, flexible coupling ⁵⁾ | Type 899.01._.3_ 92 Sh A | T _{KN} / T _{Kmax} | [Nm] | 35 / 70 | 95 / 190 | 190 / 380 | 190 / 380 | 265 / 530 | 310 / 620 |
| | Type 899.01._.2_ 98 Sh A | T _{KN} / T _{Kmax} | [Nm] | 60 / 120 | 160 / 320 | 325 / 650 | 325 / 650 | 450 / 900 | 525 / 1050 |
| | Type 899.01._.1_ 64 Sh D | T _{KN} / T _{Kmax} | [Nm] | 75 / 150 | 200 / 400 | 405 / 810 | 405 / 810 | 560 / 1120 | 655 / 1310 |
| Weight | Type 899.01._. _ | m | [kg] | 7.5 | 14 | 23 | 27 | 45 | 60 |
| Mass Moment of Inertia Rotor + hub with d _{max} | Type 899.011._. _ | J _{R+N} | [10-4 kgm ²] | 7.5 | 18.5 | 60 | 67 | 137 | 235 |
| | Type 899.012._. _ | | 8.5 | 21.5 | 70 | 77 | 151 | 250 | |

| Dimensions | | Size | | | | | |
|------------------------------|--------------------------------|----------------|-------|---------|---------|----------|----------|
| | | 120 | 150 | 175 | 200 | 230 | 260 |
| A | | 160 | 190 | 232 | 246 | 305 | 345 |
| a1 | | 20 | 20.5 | 16 | 16 | 32 | 23 |
| B2 | | 12 | 14 | 20 | 20 | 25 | 25 |
| B3 | | 76 | 83 | 90 | 92 | 92 | 92 |
| b | | 20 | 24 | 25 | 28 | 30 | 30 |
| C | | 58 | 58 | 58 | 58 | 75 | 75 |
| C2 | | 37 | 37 | 37 | 37 | 56 | 56 |
| D | | 126 | 155 | 176 | 194 | 235 | 264 |
| L2 | | 120 | 136 | 160 | 160 | 185 | 185 |
| Bores ⁶⁾ | ∅ d ₂ ^{H6} | 15-28 | 19-38 | 20-45 | 20-45 | 28-50 | 35-60 |
| | ∅ d ₃ ^{F7} | 15-28 | 19-35 | 20-45 * | 20-45 * | 28-50 | 35-55 * |
| | ∅ d ₄ ^{H7} | 15-28 | 19-38 | 20-45 * | 20-45 * | 28-50 | 35-60 * |
| Required shaft length | l2 | 25-52 | 30-60 | 35-75 | 35-75 | 40-80 | 40-80 |
| | l3 | 40-50 | 50-58 | 58-80 * | 58-80 * | 80-110 * | 80-110 * |
| m ⁷⁾ | | 130 | 165 | 200 | 215 | 265 | 300 |
| m1 | | 130 (115**) | 165 | 200 | 215 | 265 | 300 |
| s ⁷⁾ | | 9 | 11 | 13.5 | 13.5 | 13.5 | 18 |
| s1 | | 4xM8 | 4xM10 | 4xM12 | 4xM12 | 4xM12 | 4xM16 |
| SW | | 5 | 6 | 6 | 6 | 8 | 10 |
| SW1 | | 4 | 4 | 5 | 5 | 6 | 6 |
| Zj6 | | 110 | 130 | 114.3 | 180 | 230 | 250 |
| | | 95 | 110 | - | 130 | - | - |
| Z1 ^{F8} | | 110 | 130 | 114.3 | 180 | 230 | 250 |
| | | 95 | 110 | - | 130 | - | - |
| z | | 3 | 3.5 | 3.5 | 4 | 5 | 5 |
| z1 | | 5 | 5 | 10 | 6 | 10 | 10 |

Operational Instructions for ROBA®-topstop® Type 899. _ _ _ . _ _ _ Sizes 100 - 260

(B.8.8.EN)

| Preferred Bore | | d2/ d4 | Size | | | | | | |
|---|---------------------|-----------------------|------|-----|-----|------|------|-----|------|
| | | | 120 | 150 | 175 | 200 | 230 | 260 | |
| Frictionally- locking trans- mittable tor- ques shrink disk hub | T _R [Nm] | Ø 15 | 56 | - | - | - | - | - | |
| | | Ø 16 | 62 | - | - | - | - | - | |
| | | Ø 19 | 81 | 141 | - | - | - | - | |
| | | Ø 22 | 87 | 153 | 197 | 197 | - | - | |
| | | Ø 24 | 120 | 203 | 261 | 261 | - | - | |
| | | Ø 25 | 125 | 216 | 279 | 279 | - | - | |
| | | Ø 28 | 135 | 256 | 332 | 332 | 300 | - | |
| | | Ø 30 | - | 282 | 368 | 368 | 350 | - | |
| | | Ø 32 | - | 308 | 405 | 405 | 400 | - | |
| | | Ø 35 | - | 343 | 460 | 460 | 500 | 450 | |
| | | Ø 38 | - | 373 | 513 | 513 | 600 | 500 | |
| | | Suitable for H6/k6 | Ø 40 | - | - | 547 | 547 | 680 | 600 |
| | | | Ø 42 | - | - | 577 | 577 | 730 | 720 |
| | | | Ø 45 | - | - | 617 | 617 | 790 | 850 |
| | | | Ø 48 | - | - | - | - | 850 | 1000 |
| | | | Ø 50 | - | - | - | - | 880 | 1180 |
| | | | Ø 52 | - | - | - | - | - | 1270 |
| | | | Ø 55 | - | - | - | - | - | 1353 |
| Ø 58 | - | | - | - | - | - | 1428 | | |
| Ø 60 | - | - | - | - | - | 1471 | | | |

The transmittable torques for the clamping connection allow for the max. tolerance backlash on a:

- solid shaft: Tolerance k6 / bores Ø d₂ and Ø d₄: tolerance H6,
- solid shaft: Tolerance k6 / bore Ø d₃: tolerance F7.

If the tolerance backlash is larger, the torque decreases.

| Preferred Bore | | d3 | Size | | | | | | |
|--|---------------------|-----------------|------|-----|-----|-----|-----|-----|-----|
| | | | 120 | 150 | 175 | 200 | 230 | 260 | |
| Frictionally- locking trans- mittable tor- ques clamp- ing hub | T _R [Nm] | Ø 15 | 34 | - | - | - | - | - | |
| | | Ø 16 | 36 | - | - | - | - | - | |
| | | Ø 19 | 43 | 79 | - | - | - | - | |
| | | Ø 20 | 45 | 83 | 83 | 83 | - | - | |
| | | Ø 22 | 50 | 91 | 91 | 91 | - | - | |
| | | Ø 24 | 54 | 100 | 100 | 100 | - | - | |
| | | Ø 25 | 57 | 104 | 104 | 104 | - | - | |
| | | Ø 28 | 63 | 116 | 116 | 116 | 208 | - | |
| | | Ø 30 | - | 124 | 124 | 124 | 228 | - | |
| | | Ø 32 | - | 133 | 133 | 133 | 248 | - | |
| | | Ø 35 | - | 145 | 145 | 145 | 280 | 350 | |
| | | Ø 38 | - | - | 158 | 158 | 315 | 390 | |
| | | Valid for F7/k6 | Ø 40 | - | - | 166 | 166 | 340 | 420 |
| | | | Ø 42 | - | - | 174 | 174 | 365 | 455 |
| | | | Ø 45 | - | - | 187 | 187 | 404 | 505 |
| Ø 48 | - | | - | - | - | 442 | 560 | | |
| Ø 50 | - | | - | - | - | 470 | 600 | | |
| Ø 52 | - | | - | - | - | - | 640 | | |
| Ø 55 | - | | - | - | - | - | 705 | | |

- 1) Braking torque tolerance -20 % / +40 %
- 2) Coil capacity on overexcitation
- 3) Coil capacity at holding voltage
- 4) Braking torque Increased only with overexcitation (see 7.4.1.3)
- 5) For further information on flexible coupling e.g. angle misalignments, spring stiffness or temperature resistance please see ROBA®-ES catalogue [K.940.V__](#)
- 6) The transmittable torques in bores d₂, d₃ and d₄ are dependent on the diameter, see tables "Preferred Bores" 5.2.3.

- *) - Sizes 175 and 200: At a shaft length of more than 60 mm, only possible with a bored elastomeric element (max. through hole Ø38 mm)
- Size 260: At a shaft length of more than 85 mm, only possible with a bored elastomeric element (max. through hole Ø48 mm)
- ***) Optionally available with pitch circle m1 = 115

We reserve the right to make dimensional and constructional alterations.

5.2.4 Type 899.11. . . .

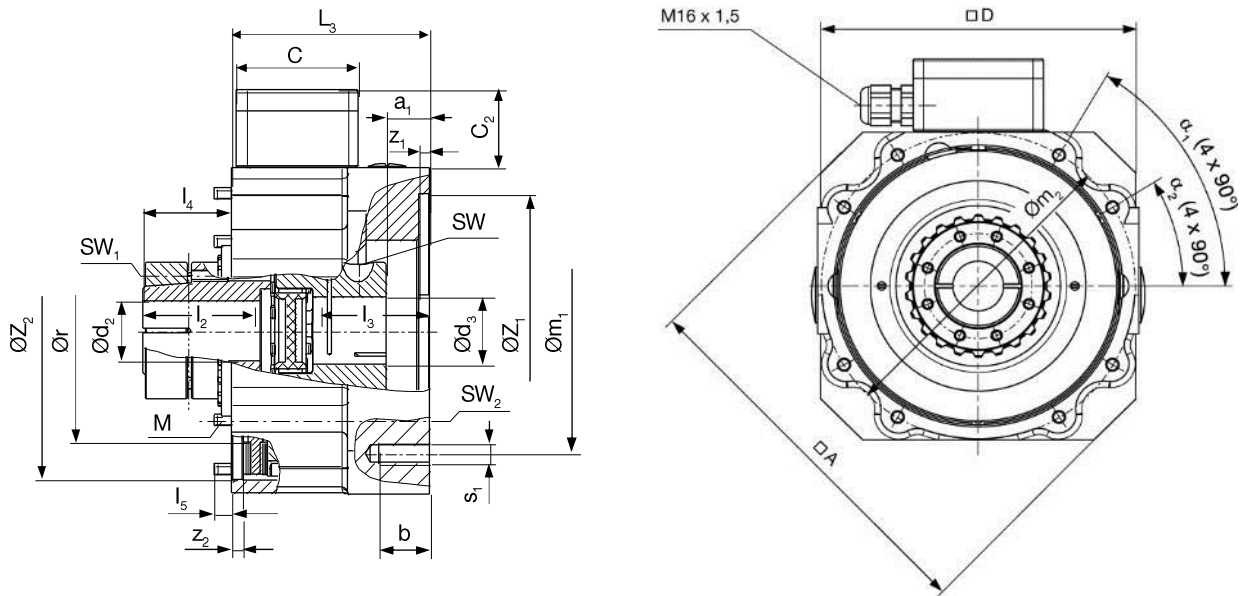

Fig. 15 Type 899.111. . . .
Brake module without output flange with plug-in shaft coupling (clamping hub motor-side)

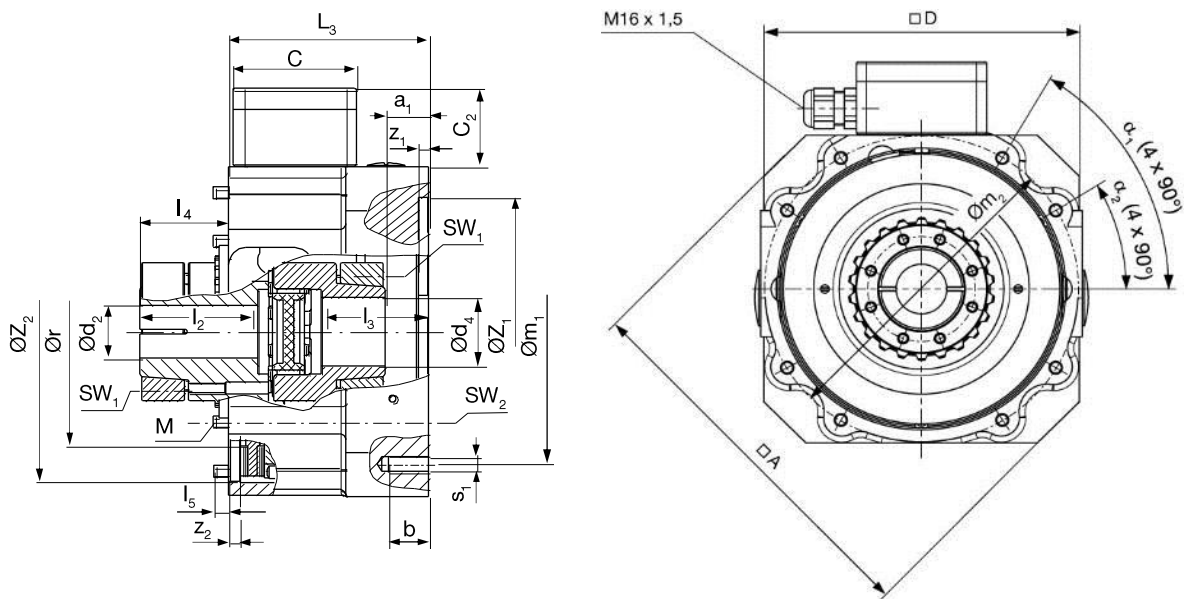

Fig. 16 Type 899.112. . . .
Brake module without output flange with plug-in shaft coupling (shrink disk hub motor-side)

Operational Instructions for ROBA®-topstop® Type 899. _ _ _ . _ _ _ Sizes 100 - 260

(B.8.8.EN)

| Technical Data | | | | Size | | | | | |
|--|-------------------------------|-------------------------------------|-------|------------|----------|----------|-----------|-----------|-----------|
| | | | | 120 | 150 | 175 | 200 | 230 | 260 |
| Braking torque ¹⁾ M _N | Type 899.11._.1 | Standard | [Nm] | 12 | 45 | 70 | 100 | 150 | 200 |
| | | Braking torque range -20% / +40% | [Nm] | 9.6 / 16.8 | 36 / 63 | 56 / 98 | 80 / 140 | 120 / 210 | 160 / 280 |
| | Type 899.11._.2 ⁴⁾ | Increased | [Nm] | 30 | 90 | 120 | 160 | 300 | 400 |
| | | Braking torque range -20% / +40% | [Nm] | 24 / 42 | 72 / 126 | 96 / 168 | 128 / 224 | 240 / 420 | 320 / 560 |
| Electrical power | Type 899.11._.1 | P _N | [W] | 31.5 | 44 | 50 | 60 | 86 | 86 |
| | Type 899.11._.2 | P _O ²⁾ | [W] | 102 | 128 | 128 | 148 | 200 | 200 |
| | | P _H ³⁾ | [W] | 26 | 32 | 32 | 38 | 50 | 50 |
| Maximum speed | Type 899.11._.1 | n _{max} | [rpm] | 5000 | 4000 | 4000 | 3000 | 3000 | 3000 |

| Size of Flexible Coupling ⁵⁾ (ROBA®-ES) | | | [-] | 24 | 28 | 38 | 38 | 42 | 48 |
|--|--------------------------|-------------------------------------|--------------------------|----------|-----------|-----------|-----------|------------|------------|
| Nominal and maximum torques, flexible coupling ⁵⁾ | Type 899.11._.3_ 92 Sh A | T _{KN} / T _{Kmax} | [Nm] | 35 / 70 | 95 / 190 | 190 / 380 | 190 / 380 | 265 / 530 | 310 / 620 |
| | Type 899.11._.2_ 98 Sh A | T _{KN} / T _{Kmax} | [Nm] | 60 / 120 | 160 / 320 | 325 / 650 | 325 / 650 | 450 / 900 | 525 / 1050 |
| | Type 899.11._.1_ 64 Sh D | T _{KN} / T _{Kmax} | [Nm] | 75 / 150 | 200 / 400 | 405 / 810 | 405 / 810 | 560 / 1120 | 655 / 1310 |
| Weight | Type 899.11._. _ _ | m | [kg] | 4.5 | 8.5 | 14 | 16 | 27 | 35 |
| Mass Moment of Inertia Rotor + hub with d _{max} | Type 899.111._. _ _ | J _{R+N} | [10-4 kgm ²] | 7.5 | 18.5 | 60 | 67 | 137 | 235 |
| | Type 899.112._. _ _ | | | 8.5 | 21.5 | 70 | 77 | 151 | 250 |

| Dimensions | Size | | | | | | |
|-----------------------|--------------------|-------|-------|--------|--------|---------|---------|
| | 120 | 150 | 175 | 200 | 230 | 260 | |
| A | 160 | 190 | 232 | 246 | 305 | 345 | |
| a1 | 20 | 20.5 | 16 | 16 | 32 | 23 | |
| b | 20 | 24 | 25 | 28 | 30 | 30 | |
| C | 58 | 58 | 58 | 58 | 75 | 75 | |
| C2 | 37 | 37 | 37 | 37 | 56 | 56 | |
| D | 126 | 155 | 176 | 194 | 235 | 264 | |
| L3 | 84 | 94 | 107.5 | 107.5 | 133 | 133 | |
| Bores ⁶⁾ | Ø d2 ^{H6} | 15-28 | 19-38 | 20-45 | 20-45 | 28-50 | 35-60 |
| | Ø d3 ^{F7} | 15-28 | 19-35 | 20-45* | 20-45* | 28-50 | 35-55* |
| | Ø d4 ^{H7} | 15-28 | 19-38 | 20-45* | 20-45* | 28-50 | 35-60* |
| Required shaft length | I2 | 25-52 | 30-60 | 35-75 | 35-75 | 40-80 | 40-80 |
| | I3 | 40-50 | 50-58 | 58-80* | 58-80* | 80-110* | 80-110* |
| I4 | 36 | 42 | 52.5 | 52.5 | 52 | 52 | |
| I5 | 7 | 10 | 12 | 12 | 16 | 16 | |
| M | 8xM5 | 8xM6 | 8xM6 | 8xM8 | 8xM8 | 8xM10 | |
| m1 | 130 (115**) | 165 | 200 | 215 | 265 | 300 | |
| m2 | 122 | 154 | 185 | 200 | 248 | 280 | |
| r | 83 | 106 | 135 | 140 | 165 | 195 | |
| s1 | 4xM8 | 4xM10 | 4xM12 | 4xM12 | 4xM12 | 4xM16 | |
| SW | 5 | 6 | 6 | 6 | 8 | 10 | |
| SW1 | 4 | 4 | 5 | 5 | 6 | 6 | |
| SW2 | 4 | 5 | 5 | 6 | 6 | 8 | |
| Z1 ^{j6} | 110 | 130 | 114.3 | 180 | 230 | 250 | |
| | 95 | 110 | - | 130 | - | - | |
| Z2 ^{H7} | 111 | 141 | 170 | 186 | 229 | 256 | |
| z1 | 5 | 5 | 10 | 6 | 10 | 10 | |
| Z2 -0.03 | 5.5 | 5.5 | 6 | - | 8 | 8 | |

| Dimensions | Size | | | | | |
|------------|------|------|------|------|------|------|
| | 120 | 150 | 175 | 200 | 230 | 260 |
| α1 | 30 ° | 31 ° | 30 ° | 30 ° | 30 ° | 30 ° |
| α2 | 60 ° | 59 ° | 60 ° | 60 ° | 60 ° | 60 ° |

| Preferred Bore | d2/ d4 | Size | | | | | |
|--|---|------|-----|-----|-----|-----|------|
| | | 120 | 150 | 175 | 200 | 230 | 260 |
| Frictionally-locking transmittable torques shrink disk hub | Ø 15 | 56 | - | - | - | - | - |
| | Ø 16 | 62 | - | - | - | - | - |
| | Ø 19 | 81 | 141 | - | - | - | - |
| | Ø 20 | 87 | 153 | 197 | 197 | - | - |
| | Ø 22 | 100 | 177 | 228 | 228 | - | - |
| | Ø 24 | 120 | 203 | 261 | 261 | - | - |
| | Ø 25 | 125 | 216 | 279 | 279 | - | - |
| | Ø 28 | 135 | 256 | 332 | 332 | 300 | - |
| | Ø 30 | - | 282 | 368 | 368 | 350 | - |
| | Ø 32 | - | 308 | 405 | 405 | 400 | - |
| | Ø 35 | - | 343 | 460 | 460 | 500 | 450 |
| | Ø 38 | - | 373 | 513 | 513 | 600 | 500 |
| | Ø 40 | - | - | 547 | 547 | 680 | 600 |
| | Ø 42 | - | - | 577 | 577 | 730 | 720 |
| | T _R [Nm] Suitable for H6/k6 | Ø 45 | - | - | 617 | 617 | 790 |
| Ø 48 | | - | - | - | - | 850 | 1000 |
| Ø 50 | | - | - | - | - | 880 | 1180 |
| Ø 52 | | - | - | - | - | - | 1270 |
| Ø 55 | | - | - | - | - | - | 1353 |
| Ø 58 | | - | - | - | - | - | 1428 |
| Ø 60 | | - | - | - | - | - | 1471 |

Operational Instructions for ROBA®-topstop® Type 899. _ _ _ . _ _ _ Sizes 100 - 260

(B.8.8.EN)

The transmittable torques for the clamping connection allow for the max. tolerance backlash on a:

- solid shaft: Tolerance k6 / bores $\varnothing d_2$ and $\varnothing d_4$: tolerance H6
- solid shaft: Tolerance k6 / bore $\varnothing d_3$: tolerance F7.

If the tolerance backlash is larger, the torque decreases.

| Preferred Bore | d3 | Size | | | | | |
|--|------------------|------------------|-----|-----|-----|-----|-----|
| | | 120 | 150 | 175 | 200 | 230 | 260 |
| Frictionally-locking transmittable torques clamping hub | $\varnothing 15$ | 34 | - | - | - | - | - |
| | $\varnothing 16$ | 36 | - | - | - | - | - |
| | $\varnothing 19$ | 43 | 79 | - | - | - | - |
| | $\varnothing 20$ | 45 | 83 | 83 | 83 | - | - |
| | $\varnothing 22$ | 50 | 91 | 91 | 91 | - | - |
| | $\varnothing 24$ | 54 | 100 | 100 | 100 | - | - |
| | $\varnothing 25$ | 57 | 104 | 104 | 104 | - | - |
| | $\varnothing 28$ | 63 | 116 | 116 | 116 | 208 | - |
| | $\varnothing 30$ | - | 124 | 124 | 124 | 228 | - |
| | $\varnothing 32$ | - | 133 | 133 | 133 | 248 | - |
| | $\varnothing 35$ | - | 145 | 145 | 145 | 280 | 350 |
| | $\varnothing 38$ | - | - | 158 | 158 | 315 | 390 |
| | $\varnothing 40$ | - | - | 166 | 166 | 340 | 420 |
| | $\varnothing 42$ | - | - | 174 | 174 | 365 | 455 |
| | $\varnothing 45$ | - | - | 187 | 187 | 404 | 505 |
| | Valid for F7/k6 | $\varnothing 48$ | - | - | - | - | 442 |
| $\varnothing 50$ | | - | - | - | - | 470 | 600 |
| $\varnothing 52$ | | - | - | - | - | - | 640 |
| $\varnothing 55$ | | - | - | - | - | - | 705 |
| $\varnothing 55$ | | - | - | - | - | - | 705 |

- 1) Braking torque tolerance -20 % / +40 %
 - 2) Coil capacity on overexcitation
 - 3) Coil capacity at holding voltage
 - 4) Braking torque Increased only with overexcitation (see 7.4.1.3)
 - 5) For further information on flexible coupling e.g. angle misalignments, spring stiffness or temperature resistance please see ROBA®-ES catalogue [K.940.V _ _ _](#)
 - 6) The transmittable torques in bores d_2 , d_3 and d_4 are dependent on the diameter, see tables "Preferred Bores" 5.2.3.
 - 7) Maximum bore in flange (customer-side) at least 4 mm smaller than \varnothing
- *) - Sizes 175 and 200: At a shaft length of more than 60 mm, only possible with a bored elastomeric element (max. through hole $\varnothing 38$ mm)
- Size 260: At a shaft length of more than 85 mm, only possible with a bored elastomeric element (max. through hole $\varnothing 48$ mm)
- **) Optionally available with pitch circle $m1 = 115$

We reserve the right to make dimensional and constructional alterations.

5.3 Switching Times

The switching times are only valid for the stated braking torque values and can only be achieved using the respective correct electrical wiring. This also refers to the protection circuit for brake control and the response delay times of all control components.

According to directive VDI 2241, the switching times are measured at a sliding speed of 1 m/s with reference to a mean friction radius. The brake switching times are influenced by the temperature, by the air gap between the armature disk and the coil carrier, which depends on the wear status of the linings, and by the type of voltage-limiting components.

The values stated in the table are mean values which refer to the nominal air gap and the nominal torque on a warm brake.

Typical switching time tolerances are ±20 %.

Please Observe:

Wear on the rotor increases the air gap. The separation time t_2 (release) increases by a factor of 2 at the end of the tension path (max. possible air gap).

Please Observe: DC-side switching

When measuring the DC-side switching times (t_{11} – time), the inductive switch-off voltage peaks are according to VDE 0580 limited to values smaller than 1200 volts. If other voltage-limiting components are installed, this switching time t_{11} and therefore also switching time t_1 increase.

Switching times Type 899. _ _ . _ _ _ 1, brake operation with braking torque **Standard** (without overexcitation)

| Switching Times Type 899. _ _ . _ _ _ 1 | | | Size | | | | | | |
|--|----|---------------|------|-----|-----|-----|-----|-----|-----|
| | | | 100 | 120 | 150 | 175 | 200 | 230 | 260 |
| Braking Torque | | [Nm] | 6 | 12 | 45 | 70 | 100 | 150 | 200 |
| Switching | | | | | | | | | |
| Connection time (close) | DC | t_1 [ms] | 65 | 55 | 80 | 85 | 90 | 160 | 200 |
| | AC | t_1 [ms] | 350 | 300 | 400 | 450 | 600 | 700 | 800 |
| Response delay on connection | DC | t_{11} [ms] | 50 | 40 | 50 | 50 | 55 | 70 | 75 |
| | AC | t_{11} [ms] | 300 | 250 | 350 | 400 | 500 | 600 | 650 |
| Separation time | | t_2 [ms] | 70 | 80 | 150 | 150 | 200 | 230 | 250 |

Switching times Type 899. _ _ . _ _ _ 2, brake operation with braking torque **Increased** (with overexcitation)

| Switching Times Type 899. _ _ . _ _ _ 2 | | | Size | | | | | | |
|--|----|---------------|------|-----|-----|-----|-----|-----|-----|
| | | | 100 | 120 | 150 | 175 | 200 | 230 | 260 |
| Braking Torque | | [Nm] | 12 | 30 | 90 | 400 | 160 | 300 | 400 |
| Switching | | | | | | | | | |
| Connection time (close) | DC | t_1 [ms] | 40 | 40 | 50 | 55 | 60 | 100 | 120 |
| | AC | t_1 [ms] | 200 | 160 | 250 | 270 | 300 | 360 | 400 |
| Response delay on connection | DC | t_{11} [ms] | 25 | 20 | 25 | 25 | 30 | 35 | 35 |
| | AC | t_{11} [ms] | 175 | 125 | 200 | 200 | 250 | 280 | 300 |
| Separation time (re- | | t_2 [ms] | 60 | 60 | 100 | 100 | 150 | 200 | 200 |

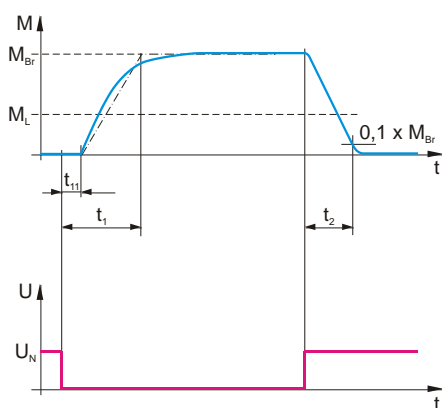

Diagram 1:
Switching times Type 899. _ _ . _ _ _ 1, brake operation with coil nominal voltage

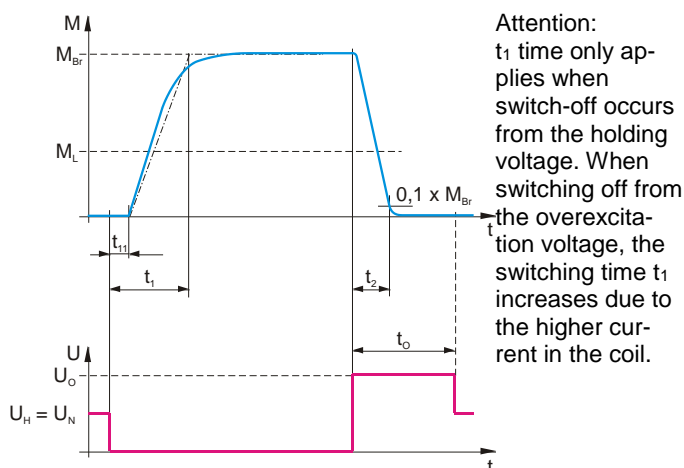

Diagram 2:
Switching times Type 899. _ _ . _ _ _ 2, brake operation with overexcitation voltage

Attention:
 t_1 time only applies when switch-off occurs from the holding voltage. When switching off from the overexcitation voltage, the switching time t_1 increases due to the higher current in the coil.

Keys

M_{Br} = Braking torque t_1 = Connection time t_2 = Separation time U_H = Holding voltage
 M_L = Load torque t_{11} = Response delay on connection t_o = Overexcitation time U_N = Coil nominal voltage
 U_o = Overexcitation voltage



On brake operation with overexcitation voltage, at least 2.5 times the brake separation time t_2 must be selected as overexcitation time t_O : $t_O \geq 2.5 \times t_2$.

It is possible to reduce the connection times (t_1 / t_{11}) by 20 – 50 % using suitable wiring.

► **Please contact *mayr*[®] power transmission.**



Check the overexcitation time even when using *mayr*[®]-DC voltage modules, as the overexcitation time is not pre-set ex works.

5.4 Friction Power / Friction Work

Permitted Friction Work Values

The brake linings are not maintenance-free. During each braking procedure, lining wear occurs. The linings or the entire rotor must be replaced after a defined number of braking actions. The number of possible switchings is dependent on the switching work per switching and the speed. When the wear becomes excessive, the brake will no longer release. The electromagnet is too weak to attract the armature disk via the large air gap. The brake remains in braking position. The braking torque is guaranteed. No signal change takes place on the release monitoring, and the machine should report a fault. This condition is not achieved on such applications under "normal" conditions, as the brake only acts with a holding function when at a standstill and with the axis drives switched off. Only in case of emergency does the brake have to delay the axis. In this case, lining wear occurs. The wear reserve on the friction linings is however dimensioned for several 10 000 such braking actions without a malfunction occurring.



For safety reasons, the ROBA®-topstop® safety brake is only to be used as a holding brake with a possible number of dynamic EMERGENCY STOP braking actions.

Not suitable for cyclic STOP braking actions in cycle operation.

When using the ROBA®-topstop® safety brake in gravity-loaded axes, the number of dynamic EMERGENCY STOP braking actions should not exceed approx. 2000 times within the total application timeframe.

For dynamic EMERGENCY STOP braking actions, the following maximum switching work values are possible:

- a) The switching work values stated in the table are valid for a max. switching frequency of 1-3 switchings (= individual events) per hour.

| Permitted Switching Work $Q_{r \text{ zul.}}$ per Braking | | | | Speed | | | | | | |
|---|------|----------------|----------|----------------------|------------------------|------------------------|------------------------|------------------------|------------------------|------|
| | Size | Type | | | 1500 min ⁻¹ | 3000 min ⁻¹ | 4000 min ⁻¹ | 5000 min ⁻¹ | 6000 min ⁻¹ | |
| $Q_{r \text{ zul.}}$ | 100 | 899. _ _ _ . 1 | Standard | Braking torque M_N | J/braking] | 7000 | 5500 | 4000 | 3000 | 2000 |
| | | | | | | 899. _ _ _ . 2 | Increased | 4500 | 3000 | 2000 |
| | 120 | 899. _ _ _ . 1 | Standard | | | 9000 | 4500 | 1500 | 1000 | - |
| | | | | | | 899. _ _ _ . 2 | Increased | 6000 | 2500 | 700 |
| | 150 | 899. _ _ _ . 1 | Standard | | | 11000 | 6000 | 2000 | - | - |
| | | | | | | 899. _ _ _ . 2 | Increased | 7500 | 3500 | 1000 |
| | 175 | 899. _ _ _ . 1 | Standard | | | 15000 | 7500 | 4500 | - | - |
| | | | | | | 899. _ _ _ . 2 | Increased | 9000 | 4500 | 2400 |
| | 200 | 899. _ _ _ . 1 | Standard | | | 22000 | 9000 | - | - | - |
| | | | | | | 899. _ _ _ . 2 | Increased | 15000 | 6000 | - |
| | 230 | 899. _ _ _ . 1 | Standard | | | 27000 | 11000 | - | - | - |
| | | | | | | 899. _ _ _ . 2 | Increased | 16000 | 6500 | - |
| | 260 | 899. _ _ _ . 1 | Standard | | | 32000 | 14000 | - | - | - |
| | | | | | | 899. _ _ _ . 2 | Increased | 18000 | 6500 | - |

- b) For a switching frequency of up to 10 switchings per hour a factor of 0.5 for the stated switching work values must be taken into account.
Example: Size 120 / Type 899. _ _ _ . 2 / speed = 1500 rpm => permitted friction work $Q_{r \text{ zul.}}$ = 3000 J/braking action.
- c) Special dimensioning is necessary for higher speeds. ► Please contact **mayr®**.

| Permitted Friction Work $Q_{r \text{ ges.}}$ up to Rotor Replacement | | Size | | | | | | |
|--|-------|------|-----|-----|-----|-----|-----|-----|
| | | 100 | 120 | 150 | 175 | 200 | 230 | 260 |
| $Q_{r \text{ ges.}}$ | 106 J | 17 | 28 | 65 | 100 | 180 | 240 | 300 |



Due to various operating parameters such as sliding speed, pressing or temperature the wear values can only be considered guideline values.

6 Intended Use

See also section [2.3](#)

6.1 Guidelines for Application

- Only for use as holding brake with a limited number of EMERGENCY STOP braking actions. Not suitable for cyclic STOP braking actions in cycle operation. With designs featuring an optional release monitoring with microswitch, please observe the switching frequency.
- Please observe the correct dimensioning of speed, braking torque, friction work and switching frequency in case of EMERGENCY STOP for safe holding of the load torque and safe compliance of the required braking distance and overtravel time.
- The stated switching times can only be achieved using the respective correct electrical wiring. This also refers to the protection circuit for brake control and the response delay times of all control components.
- Temperatures over 80 °C on the brake housing when the machine is in use may influence the switching times and braking torque levels. The brake and the achieved braking torque must be tested in the application.
- Application in clean environments (penetration of coarse dust and liquids such as oils can have a negative effect on the braking function).
- Application in enclosed buildings (In tropical regions, in high humidity with long downtimes and sea climates only after taking special measures).
- Intended for motor-side mounting onto synchronous and asynchronous servomotors.

6.2 Limits

- Not suitable for permanent braking of a rotary movement (e.g. start - stop operation)
- The brake is not suitable for use in oily or severely contaminated environments
- The brake is not suitable for application in high ambient temperatures >40 °C
- The brake is not suitable for application in high air humidity > 80 % rel. air humidity
- The brake is not suitable for mounting onto a combustion engine

6.3 Reasonably Foreseeable Misuse

The following uses are prohibited and may generate hazards.

- Any opening of the screws on the housing.
- Use of the brake in an oily environment
- Starting up against a closed brake due to incorrect release monitoring evaluation. Overlaps in the control sequence.

6.4 Duration of Use

20 years or on reaching the T10d (for definition, see EN ISO 13849-1) duration of use.

6.5 Brake Dimensioning

1. Dimensioning the brake static holding torque according to the system load torque

(The carriage is held safety in the holding position via the brake)

$$M_{N -20\%} > M_L \times S$$

2. Checking the braking distance (stopping distance) by taking the following into account:

(Guaranteeing the required minimum braking distance for the protection of people or from collisions)

- All rotatory mass inertias (motor, brake, drive elements, etc.)
- All translationally moved masses and loads
- Inclination of the gravity-loaded axis
- Transmissions via gear, spur gear and toothed belt levels as well as via spindle pitches
- Path feed speed and direction from which the axis is braked
- All system times such as proximity switch response time, controls processing time and brake connection time t_1 / t_{11} - times
- Total efficiency of the input axis

The following applies: **Total braking distance < required braking distance x safety factor**



During the system running times, the input speed might increase depending on the total efficiency and load. Please take this into account when calculating the friction power

3. Taking the inspection and test torques into account

$$M_{Test} < M_{N -20\%} \times 0.9$$

4. Inspection of thermic load Q_r

$$Q_r = \frac{J \times n^2}{182.4} \times \frac{M_N}{M_V}$$

$$M_V = M_N - M_L \quad (-) \text{ is valid if load is braked during downward}$$

| | | |
|---------------|---------------------|--|
| $M_{N -20\%}$ | [Nm] | Brake minimum braking torque (= braking torque - 20% x braking torque) see Technical Data (section 5.2) |
| Q_r | [J/braking] | Friction work present per braking |
| S | [-] | Recommended safety factor min. 1.5 – 2 depending on the application* |
| J | [kgm ²] | Total mass moment of inertia referring to the brake |
| M_N | [Nm] | Brake nominal torque (see Technical Data section 5.2) |
| M_{Test} | [Nm] | Test torque as e.g. cyclic brake test (see section 11) |
| M_V | [Nm] | Deceleration torque |
| M_L | [Nm] | Load torque on system |

* Taking the machine-specific standards and specialist literature into account (state of the art)

The permitted friction work $Q_{r \text{ zul.}}$ per braking action with 1 – 3 switching actions (reduction of the friction work after several switchings), see [5.4](#).



Guaranteeing the necessary braking distances with all control and braking times in case of danger due to gravity-loaded axes must be checked via a test. A cyclic braking torque test of the brake rotor during operation provides additional safety.
Depending on the danger, please observe the respective regulations / standards.

Operational Instructions for ROBA®-topstop® Type 899. _ _ _ . _ _ _ Sizes 100 - 260

(B.8.8.EN)

6.6 Outer Parameters

6.6.1 Permitted Motor Attachments/ Breakdown Torques

The permitted breakdown torques of the motor screwed onto the brake module include the static and dynamic loads “F” of motor weight, mass acceleration and influences caused through shocks and vibrations, multiplied by the motor centre of gravity clearance „I_s“.

$$M_k = F \times I_s \leq M_{k \text{ zul.}}$$

| Permitted Breakdown Torque | [Nm] | Size | | | | | | |
|----------------------------|------|------|-----|-----|-----|-----|-----|-----|
| | | 100 | 120 | 150 | 175 | 200 | 230 | 260 |
| M _{k zul.} | | 25 | 45 | 90 | 135 | 200 | 300 | 450 |

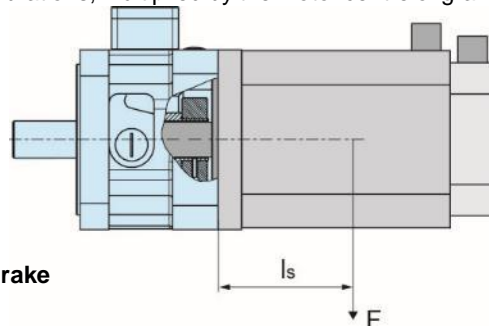

6.6.2 Permitted Outer Acceleration and Deceleration Torques on the Brake

| | Types | | | Size | | | | | | | |
|---|---|---------------------------------|---------------------|------|--|-----|-----|-----|-----|-----|-----|
| | | | | 100 | 120 | 150 | 175 | 200 | 230 | 260 | |
| 1 | Max. permitted acceleration and deceleration torque on the servomotor on the brake | all Types | M _{Beschl} | [Nm] | 15 | 40 | 100 | 150 | 200 | 300 | 500 |
| 2 | *I) Max. dynamic braking torque by the motor on the brake (servomotor with holding brake) | all Types except 899. _ _ . _ 2 | M _{Brems} | [Nm] | 7.5 | 15 | 35 | 60 | 80 | 120 | 200 |
| 3 | Max. dynamic braking torque by the motor on the brake (servomotor with holding brake) | 899. _ _ . _ 2 | M _{Brems} | [Nm] | *II) No further braking torque permitted through motor brake | | | | | | |

*I) This restriction applies when the ROBA®-topstop® brake and all further braking torques, such as for as example the motor during brake operation (eddy current operation) and/or the motor brake engage at the same time. The brake times overlap and the braking torque adds up. If it is certain that the brake times do not overlap, a braking torque via the holding brake in the servomotor (see point 1 in the table) can be permitted.

*II) No other braking torque is permitted. If it is certain that the brake times do not overlap, a braking torque via the holding brake in the servomotor (see Point 1 in the table) can be permitted.

6.6.3 Permitted Shaft Loads

Max. radial forces on the bearing applicable for: Type **899.000.0_**

| ROBA®-topstop® brake | | Size | | | | | | |
|---|-------|-------|-------|-------|-------|-------|-------|-------|
| | | 100 | 120 | 150 | 175 | 200 | 230 | 260 |
| Distance „I _R “ (Fig. 17) | [mm] | 20 | 22.5 | 30 | 40 | 40 | 55 | 55 |
| Max. permitted radial force „F _R “ with dis- | [N] | 250 | 600 | 1000 | 1500 | 1500 | 2000 | 3000 |
| The permitted forces refer to a max. speed of | [rpm] | 6000 | 5000 | 4000 | 4000 | 3000 | 3000 | 3000 |
| Nominal service life-time Fig. 17 | [h] | 30000 | 30000 | 25000 | 25000 | 15000 | 15000 | 15000 |

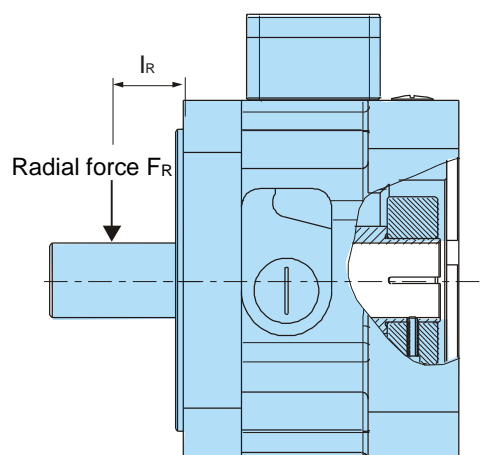

The values refer to purely radial forces. The permitted forces are applicable for shaft dimensions, with a force application point for radial forces in the centre of the output shaft.

7 Electrical Connection and Wiring

DC current is necessary for operation of the brake. The coil nominal voltage is indicated on the Type tag as well as on the brake body and is designed according to the DIN IEC 60038 ($\pm 10\%$ tolerance). Operation can take place with alternating voltage using a rectifier or another suitable DC power supply. The connection possibilities can vary dependent on the brake equipment. Please follow the exact connections according to the section **10.11**. The manufacturer and the user must observe the applicable regulations and standards (e.g. DIN EN 60204-1 and DIN VDE 0580). Their observance must be guaranteed and double-checked!

7.1 Earthing Connection

The brake is designed for Protection Class I. This protection covers not only the basic insulation, but also the connection of all conductive parts to the protective conductor (PE) on the fixed installation. If the basic insulation fails, no contact voltage will remain. Please carry out a standardised inspection of the protective conductor connections to all contactable metal parts!

For the protective conductor connection, marked connection points are available in the terminal box (15).



7.2 Fuse Element

To protect against damage from short circuits, please add suitable fuse elements to the mains cable/supply line.

7.3 Switching Behaviour

The reliable operational behaviour of a brake is to a large extent dependent on the switching mode used. Furthermore, the switching times are influenced by the temperature and the air gap between the armature disk and the coil carrier (dependent on the wear condition of the linings).

7.4 Switching Modes

The separation time (t_2) and the connection time (t_1) of the brake are substantially influenced depending on the electrical wiring of the magnetic coil (see section **5.3**).

7.4.1.1 Field Build-up with Normal Excitation

Determination of the separation time (t_2).

If the magnetic coil is energised with coil nominal voltage, the coil current does not immediately reach its nominal value. The coil inductivity causes the current to increase slowly as an exponential function. Accordingly, the build-up of the magnetic field takes place more slowly and the braking torque drop (see Diagram 3/curve 1) is also delayed.

For this type of wiring, no electrical construction elements are required as long as the DC supply voltage equals the coil nominal voltage on the magnetic coil.

7.4.1.2 Field Build-up with Overexcitation

Quicker Release

Determination of the separation time (t_2)

A quicker drop in braking torque is achieved if the coil is temporarily placed under a higher voltage than the coil nominal voltage, as the current then increases more quickly. Once the brake is released, it needs to be switched over to the coil nominal voltage U_N (see Diagram 3/curve 2). The relationship between overexcitation and separation time t_2 is roughly indirectly proportional, meaning that at doubled nominal voltage the separation time t_2 for release of the brake is halved. For this, further wiring modules are required. The ROBA®-switch and ROBA®-multiswitch work on this principle.

Increased spring force

Generally, overexcitation of the magnetic coil is also required if the brake has an increased braking torque (Type 899. _ _ _ . 2), and an increased magnetic force is required to attract the armature disk against the increased spring forces.

Current path

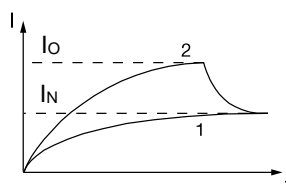

Braking torque path

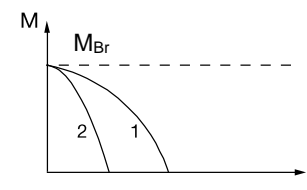

Diagram 3:

Operation with overexcitation requires an inspection of :

- the required overexcitation time
- the RMS coil capacity with a cycle frequency higher than 1 cycle per minute.

7.4.1.3 Calculation during Field Build-up with Overexcitation

Required overexcitation time

Increased wear, and therefore an increasing air gap as well as coil heating lengthen the separation times t_2 for the brake. For this reason, at least 2.5 times the separation time t_2 at nominal current I_N must be selected as overexcitation time t_o .

RMS coil capacity P



$$P \leq P_N$$

The coil capacity P must not be larger than P_N . Otherwise the coil may fail due to thermic overload.

Key and Calculations:

| | | |
|------------------|------|---|
| P | [W] | RMS coil capacity dependent on switching frequency, overexcitation, reduction in capacity and duty cycle $P = \frac{P_0 \times t_o + P_H \times t_H}{T}$ |
| P _N | [W] | Coil nominal capacity Type 899.1 (Technical Data, type tag) |
| P _O | [W] | Coil capacity on overexcitation Type 899.2 (Technical Data) |
| P _H | [W] | Coil capacity Type 899.2 (Technical Data, type tag) |
| t _o | [s] | Overexcitation time |
| t _H | [s] | Holding time Type 899.2 |
| t _{on} | [s] | Time with voltage |
| t _{off} | [s] | Time without voltage |
| T | [s] | Total time (t _o + t _H + t _{off}) |
| U _O | [V] | Overexcitation voltage (bridge voltage) |
| U _H | [V] | Holding voltage (half-wave voltage) |
| U _N | [V] | Coil nominal voltage |
| I _o | [A] | Overexcitation current |
| I _N | [A] | Nominal current |
| M _{Br} | [Nm] | Braking torque |

7.4.1.4 Time Diagram:

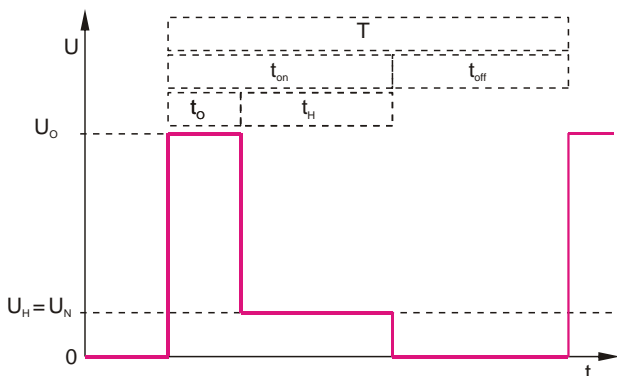

7.4.2 Magnetic field removal

Determination of the connection time (t₁)

7.4.2.1 AC-side Switching/Switching with Freewheeling Diode

a) Rectifier module for supply with AC voltage

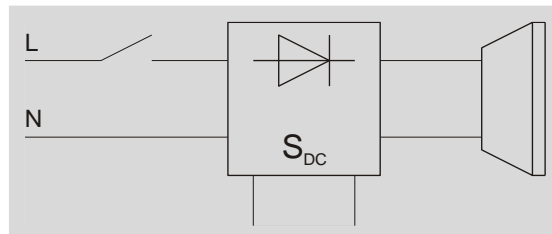

Schematic wiring diagram 1

The power circuit is interrupted in front of the rectifier. The magnetic field slowly reduces. This delays the rise in braking torque and generates a slow connection time t₁.

b) For supply with DC voltage

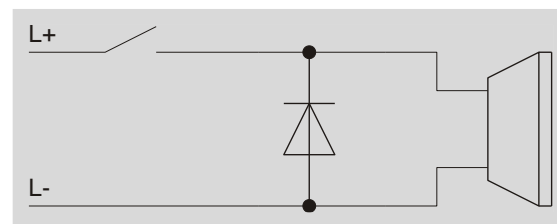

Schematic wiring diagram 2

The power circuit is interrupted in front of the freewheeling diode. The magnetic field slowly reduces. This delays the rise in braking torque and generates a slow connection time t₁. The freewheeling diode is to be dimensioned in accordance with the nominal current of the brake and the maximum occurring supply voltage with the appropriate safety factor.



Recommendation!

Connection time t₁ is of no consequence:

- Switch AC-side or with the freewheeling diode. No protective measures for the coil and switching contacts required.

AC-side switching/ switching with freewheeling diode means a longer brake engagement time (approx. 6 – 10 times longer than with DC-side switch-off), use for non-critical braking times.

7.4.2.2 DC-side switching

a) Rectifier module for supply with AC voltage

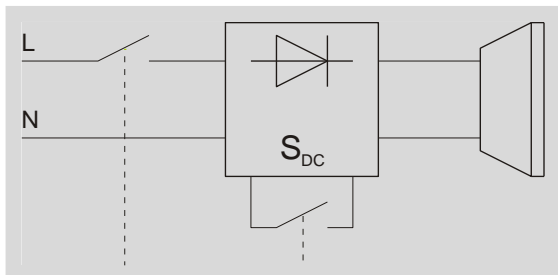

Schematic wiring diagram 3

The power circuit is interrupted between the rectifier and the coil as well as mains-side. The magnetic field reduces extremely quickly. This causes a quick rise in braking torque.

b) For supply with DC voltage

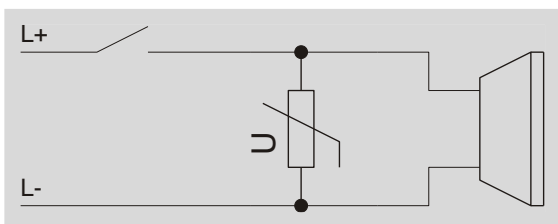

Schematic wiring diagram 4

The power circuit is interrupted between the voltage supply and the coil. The magnetic field is quickly reduced by the protective element. This causes a quick rise in braking torque and a quick connection time t_1 . The varistor is to be dimensioned in accordance with the maximum occurring DC or AC voltage. The recommended disk diameters are 14 – 20 mm.

When switching DC-side, high voltage peaks are produced in the coil. This can lead to wear on the contacts from sparks and to destruction of the insulation. For this reason, the voltage peaks must be limited (see section [7.5](#)).

DC-side switching causes the **shortest connection times on the brake (e.g. for EMERGENCY STOP operation or for safety switch-offs)** so that the braking torque is made available as quickly as possible for short braking distances or for fast take-over of loads.



Please Observe!

Safety switch-off

In applications with a necessarily short switching time for short braking distances and fast take-over of loads, reliable DC-side switch-off is required e.g. through redundant, monitored contactors. (see schematic wiring diagram 5)

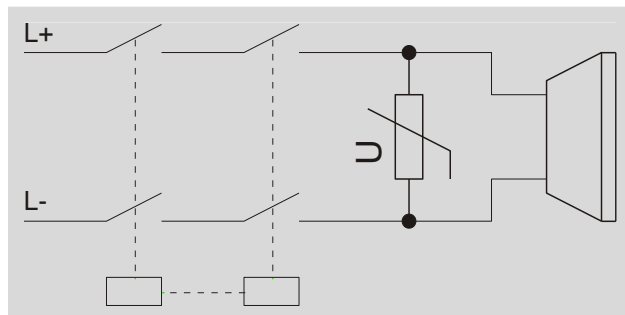

Schematic wiring diagram 5

7.5 Protection circuit

When using DC-side switching, the coil must be protected by a suitable protection circuit according to VDE 0580, which is integrated in *mayr*®-rectifiers. To protect the switching contact from consumption when using DC-side switching, additional protective measures are necessary (e.g. series connection of switching contacts). The switching contacts used should have a minimum contact opening of 3 mm and should be suitable for inductive load switching. Please make sure on selection that the rated voltage and the rated operating current are sufficient. Depending on the application, the switching contact can also be protected by other protection circuits (e.g. *mayr*®-spark quenching unit), although this may of course then alter the switching times.

The following parameters can be changed through suitable adaptations of the protection circuit.

- Contact lifetime
- Switching times on drop-out
- Voltage peaks or level of switch-off voltage

Please contact *mayr*®.



Please Observe!

For accessories, please go to www.mayr.com

8 Functional Safety Parameters

Consideration of the mean time to dangerous failure for ROBA®-topstop® brake systems in accordance with DIN EN ISO 13849-1 Safety of machinery – Safety related parts of control systems

8.1.1 Definition

The mean time to dangerous failure $MTTF_d$ describes the reliability of the components used. In DIN EN ISO 13849, the $MTTF_d$ is defined as the "Expected mean time to dangerous failure", which emphasises several aspects:

- $MTTF_d$ is a static variable, i.e. an empirically generated value or classification number which has nothing in common with a "guaranteed lifetime", "failure-free period" or similar.
- $MTTF_d$ has the physical dimension of a time and is usually stated in years. The simplified quantification procedure in accordance with DIN EN ISO 13849-1 assumes a standard duration of use of max. 20 years.
- This only concerns failures with dangerous consequences, i.e. those which affect the execution of the safety function.

The value B10d states the number of cycles until 10% of the components have suffered dangerous failures (definition acc. EN ISO 13849-1).

With regard to the brakes, these are:

- The mechanical switching process.
- The movement of the armature disk.

Here dangerous failures means that the brake does not engage on request and therefore does not generate the required braking torque.

The wear on the brake lining has no influence on this value (e.g. the wear during a dynamic braking action).

Due to the "quiescent current principle" at the wear end of the brake, the required braking torque is still available, meaning that no dangerous failures can occur.

For the precise calculation of the wear value, the braking work per switching and the switching cycle quantity in the application per year must be determined (see section [6.5](#)).

Definition of the category:

The categories classify safety-related components with regard to their resistance against errors and their behaviour in case of error, based on the reliability and the structural arrangement of the parts. A higher resistance capability against errors means a higher possible reduction of risk.

All ROBA®-topstop® brakes fulfil Category 1 in accordance with DIN EN ISO 13849-1.

Braking device as tried and tested component in terms of the Category 1 acc. DIN EN ISO 13849-1
→ see section [3.6](#)

8.1.2 Functional Safety Guidelines

The brake safety is generated through the braking torque. For safe and reliable braking and for error-free operation of the ROBA®-topstop® brakes, the following points are required:

- Sufficient dimensioning
- Intended use
- Maintenance of the application limits
- Maintenance of the technical fringe parameters



Brake dimensioning see section [6.5](#)

So that the required load torque can be held reliably, and the required braking distance can be reliably maintained, the following points are to be determined:

- The static holding torque
- The dynamic braking torque
- The speed
- The friction work per braking action
- The switching frequency
- The braking time



A positive-locking connection increases the reliability against inadvertent slipping of the connection and the related risks.

See section [4.6.1](#).

For fulfilment of the safety functions, the safety brake is only to be considered as an individual component, and not as a safety-orientated subsystem. The safety brake alone is not sufficient to execute the safety function in accordance with the standard. To do this, the brake wiring and the signal return etc. must also be observed.



In general, the following applies:

The brake provides no single error reliability.
One error, and the resulting loss of braking torque, is possible.

The efficacy and function of the brake is to be inspected due to the overall risk assessment to be carried out and the resulting measures for risk minimisation depending on the application case through suitable tests at appropriate time intervals (safe brake test SBT, safe brake management SBM, safe brake and holding system SBS etc.). The release monitoring signal can increase the diagnostic coverage DC. Brake errors which influence the release of the armature disk or the energisation of the brake can thus be determined. In order to detect effective brake or release monitoring errors, it is necessary to query the control expectations on the commands "Brake - Energised" and "Brake - De-energised" according to the Technical Data for the brake used.

Brake - energised: Signal change from "Brake closed" to "Brake open" within a certain time (e.g. 3 x t_2 -time) see section 10.12.

Brake - de-energised: Signal change from "Brake opened" to "Brake closed" within a certain time (e.g. 3 x t_1 -time) see section 10.12.



It must be ensured that the drive cannot start up against the closed brake. This can be monitored via brake-side release monitoring.



Test principle
See also the Division Information Sheet "Gravity-loaded axes – (Vertical axes)" DGUV section 6, section 11.2.

8.1.3 Condition



Brakes which are used in safety-related applications are to be selected in accordance with the risk assessment EN ISO 12100 and furthermore in accordance with EN ISO 13849-1 through identification of the safety function. This is in principle the task of the system manufacturer.

The Performance Level (PL) can only be determined on consideration of all safety-related parts of the safety channel such as the control and additional braking or holding devices etc. in accordance with EN ISO 13849-1.

9 Storage

9.1 Brake Storage

- Store the brakes in a horizontal position, in dry rooms and dust and vibration-free.
- Relative air humidity < 50 %.
- Temperature without major fluctuations within a range from 10 °C up to +40 °C.
- Do not store in direct sunlight or UV light.
- Do not store aggressive, corrosive substances (solvents / acids / lyes / salts etc.) near to the brakes.

For longer storage of more than 2 years, special measures are required.

► **Please contact *mayr*®.**

10 Installation

10.1 Mounting Conditions

- Please keep to the dimension z_2 (see sections **10.8**, **10.9**, **10.10**) for the customer-side friction flange (36) acc. table in section **4.5** (Tolerance – 0.03 mm).
- A suitable counter friction surface (steel or grey cast iron) must be used. Sharp-edged interruptions on the friction surfaces must be avoided.
- Max. permitted surface roughness depth of the friction surface $R_a = 1.6 \mu\text{m}$.
- The max. permitted unevenness of the friction surface is 0.03 mm.
- For customer-side attachment, axial run-out and shaft run-out tolerances of 0.03 mm are necessary.
Larger deviations affect the function and the installation of the brake or can lead to a drop in braking torque, to continuous grinding of the rotor (22) and to overheating.
- Tolerance for customer-side shafts: k6
- The shaft/spindle must be axially backlash-free customer-side (backlash-free locating bearing). Axial backlash affect the function of the brake or can lead to continuous grinding of the rotor (22) and to overheating.

10.2 Installation Conditions

- The rotor (22) and brake surfaces must be oil and grease-free.
- The permitted radial forces on the shaft (Item 7) acc. section **6.6.3** must not be exceeded.
- When installing a ROBA®-topstop®, do not place it on the terminal box; avoid any adjustment or damage.
- The minimum property class of the customer-side cap screws (17/18) is 8.8. Tighten the screws using a torque wrench!
- Please keep to the installation dimensions $W/Y_1/Y_2$, see table in section **4.5**, as otherwise the brake function cannot be guaranteed.
- Please make sure that the max. permitted shaft misalignments and torques defined in the Installation and Operational Instructions for the shaft coupling are not exceeded (see attached Installation and Operational Instructions B.9.6).
- Please use distance rings as limit stops for keeping to the machine-side dimensions.

WARNING Load crash possible



The brake only functions reliably subsequent to initial operation.
Support the load!

Caution



Please observe the own weight of the brake

The brake may drop during transport / assembly. The consequences may be crush injuries and impact injuries. For Size 260, use an eyebolt for lifting aids.

10.3 Brake Type 899.000.0_

Installing the brake onto the machine:

1. Open the screw plug (16). Check the alignment of the cap screw (10) and the bore for the screw plug (16) and make sure that the cap screw (10) is loosened.
2. Mount the brake assembly onto the machine using customer-side cap screws (17) (please observe the tightening torque acc. table in section **4.5**).
3. Clamp the shaft (7) onto the output side (machine-side).

Installing the motor onto the brake:

4. Push the motor (shaft) into the brake, bring it into position and tighten it to the tightening torque acc. table in section **4.5** using customer-side cap screws (18).



The shaft is centred via the rotor (22) in the brake. If necessary, release (energise) the brake if the motor cannot be inserted easily into the centering. The motor can then be moved slightly radially during joining.

Please observe the required shaft length "l₃" and the threaded hole depth "b" acc. table in section **4.5**

5. Tighten the cap screw (10) to the tightening torque acc. table in section **4.5**.
6. Close the screw plug (16) again.

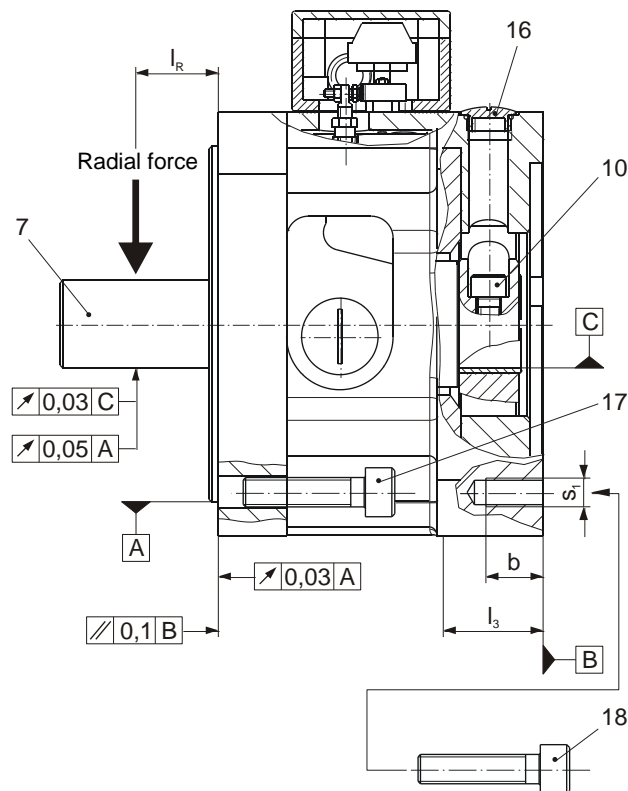

Fig. 20

10.4 Brake Type 899.001.

Installing the brake onto the machine:

1. Mount the brake assembly onto the machine using customer-side cap screws (17) (please observe the tightening torque acc. table in section 4.5).
2. Clamp the shaft (32) onto the output side (machine-side).

Installing the motor onto the brake:

3. Check whether the cap screw (4) is loosened in the clamping hub (3).
4. Push the clamping hub (3) with the inserted elastomeric element (11) onto the motor shaft, and adjust using axial movement to the installation dimension "Y1/Y2" acc. table in section 4.5. We recommend an adjusted distance ring as a fixed limit stop.



Please observe the required shaft length "l₃" acc. table in section 4.5

5. Tighten the cap screw (4) to the tightening torque acc. table in section 4.5.
6. Check the installation dimension "Y1/Y2" acc. table in section 4.5 and correct again if necessary.
7. Bring the brake and the motor into position with each other and push them together carefully. If necessary, turn the motor shaft slightly, so that the claws of the clamping hub (3) can be inserted into the elastomeric element (11).



Do not use force.
If necessary, release (energise) the brake if the motor cannot be inserted easily into the centering. The motor can then be moved slightly radially during joining.

8. Screw the brake and the motor together with each other using four customer-side cap screws (18) to the tightening torque acc. table in section 4.5.

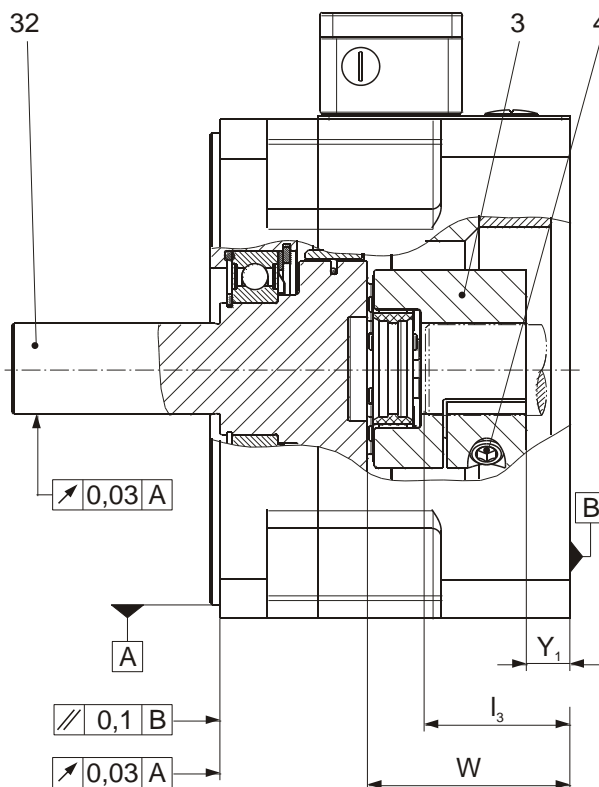

Fig. 21

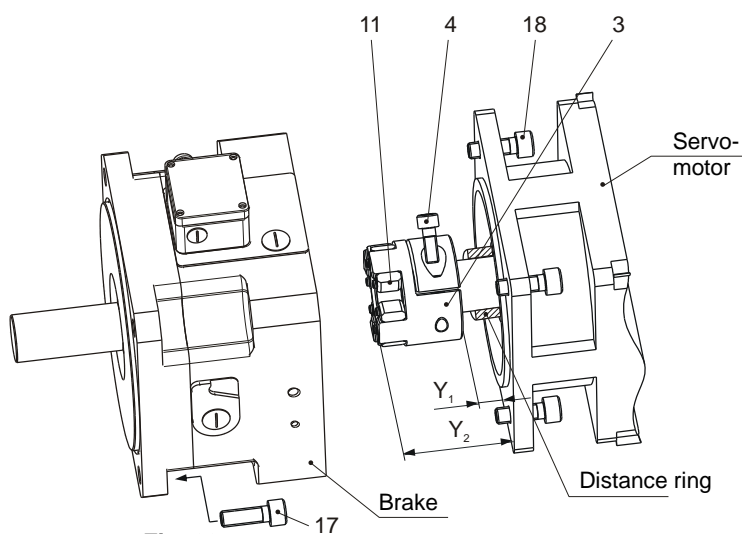

Fig. 22

10.5 Brake Type 899.002.

Installing the brake onto the machine:

1. Mount the brake assembly onto the machine using customer-side cap screws (17) (please observe the tightening torque acc. table in section 4.5).
2. Clamp the shaft (32) onto the output side (machine-side).

Installing the motor onto the brake:

3. Remove the elastomeric element (11).
4. Check whether the cap screws (6) are loosened in the input-side shrink disk hub (5).
5. Push the input-side shrink disk hub (5) onto the motor shaft, and adjust using axial movement to the installation dimension "Y1/Y2" acc. table in section 4.5. We recommend an adjusted distance ring as a fixed limit stop.



Please observe the required shaft length "l₃" acc. table in section 4.5

6. Tighten the cap screws (6) stepwise (in 3 to max. 6 tightening sequences) and cross-wise to the tightening torque acc. table in section 4.5.
7. Check the installation dimension "Y1/Y2" acc. table in section 4.5 and correct again if necessary.
8. Re-insert the elastomeric element (11).
9. Bring the brake and the motor into position with each other and push them together carefully. If necessary, turn the motor shaft slightly, so that the claws of the shrink disk hub (5) can be inserted into the elastomeric element (11).



Do not use force.
If necessary, release (energise) the brake if the motor cannot be inserted easily into the centering. The motor can then be moved slightly radially during joining.

10. Screw the brake and the motor together with each other using four customer-side cap screws (18) to the tightening torque acc. table in section 4.5.

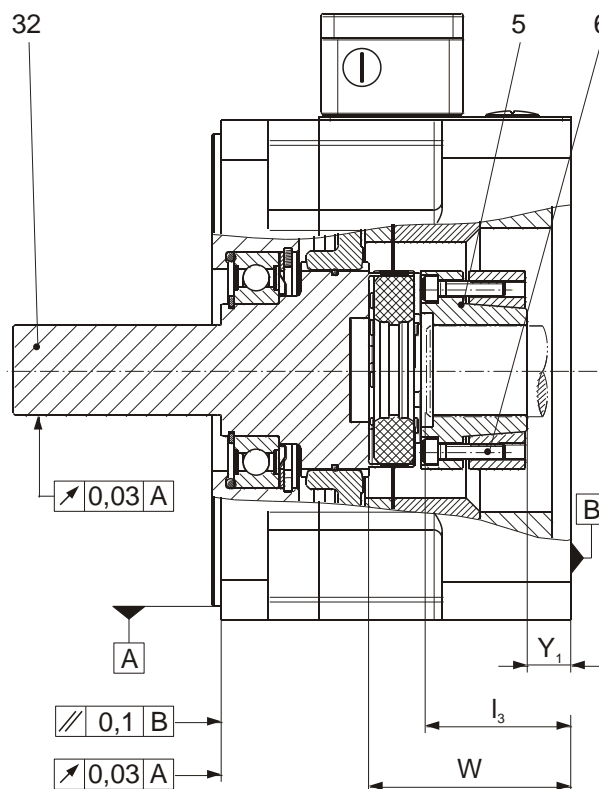

Fig. 23

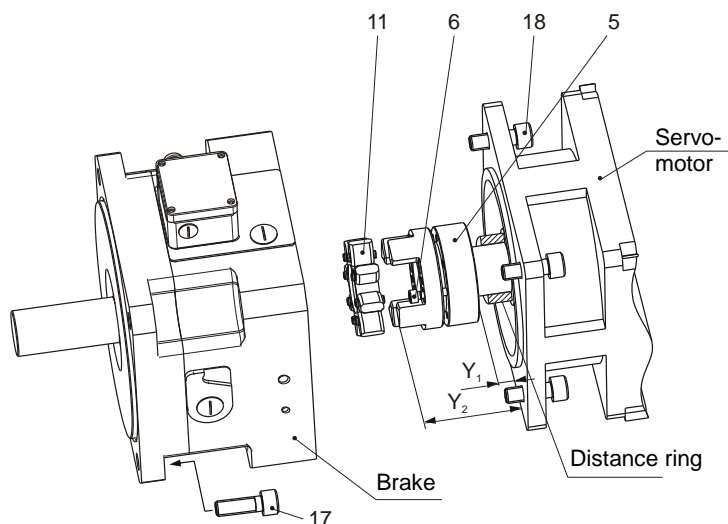

Fig. 24

10.6 Brake Type 899.011. _ _

Installing the brake onto the machine:

1. Check whether the cap screws (2) are loosened.
2. Push the pre-assembled brake over the machine shaft.



Please observe the required shaft length " l_2 " acc. table in section [4.5](#)

3. Screw in the cap screws (17) for the brake/machine (leave approx. 5 mm stroke, see Fig. 26).
4. Adjust the output-side shrink disk hub (1) using axial movement to the installation dimension " W " acc. table in section [4.5](#). We recommend an adjusted distance ring as a fixed limit stop.
5. Tighten the cap screws (2) stepwise (in 3 to max. 6 tightening sequences) and cross-wise to the tightening torque acc. table in section [4.5](#).
6. Pull the brake back to contact on the screw heads (17) (fixing screws for brake/machine), then push them again against the machine (reason: release of the rotor (22)).
7. Tighten the cap screws (17) for the brake/the machine.

Installing the motor onto the brake:

8. Check whether the cap screw (4) is loosened in the clamping hub (3).
9. Push the clamping hub (3) with the inserted elastomeric element (11) onto the motor shaft, and adjust using axial movement to the installation dimension " Y_1/Y_2 " acc. table in section [4.5](#). We recommend an adjusted distance ring as a fixed limit stop.



Please observe the required shaft length " l_3 " acc. table in section [4.5](#)

10. Tighten the cap screw (4) to the tightening torque acc. table in section [4.5](#).
11. Check the installation dimension " Y_1/Y_2 " acc. table in section [4.5](#) and correct again if necessary.
12. Bring the brake and the motor into position with each other and push them together carefully. If necessary, turn the motor shaft slightly, so that the claws of the shrink disk hub (1) can be inserted into the elastomeric element (11).



Do not use force.

If necessary, release (energise) the brake if the motor cannot be inserted easily into the centring. The motor can then be moved slightly radially during joining.

13. Screw the brake and the motor together with each other using four customer-side cap screws (18) to the tightening torque acc. table in section [4.5](#).

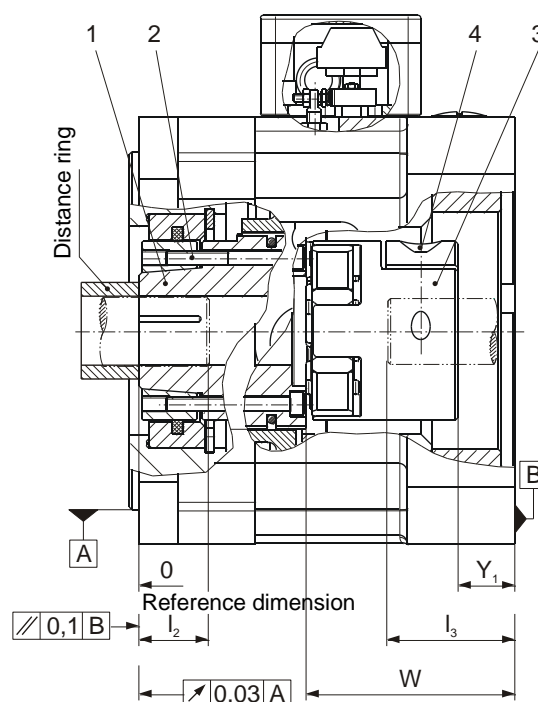

Fig. 25

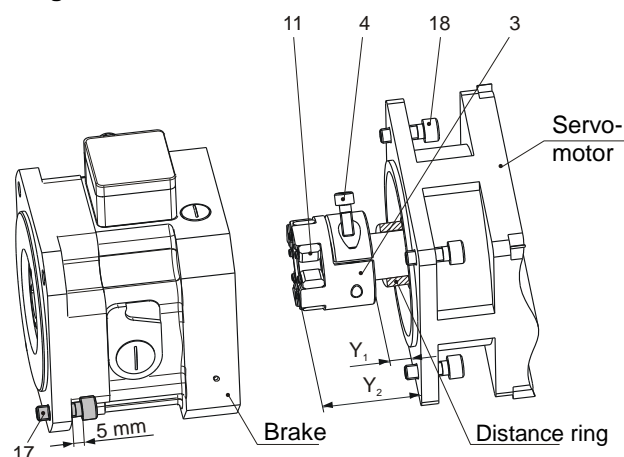

Fig. 26

10.7 Brake Type 899.012. _ _

Installing the brake onto the machine:

1. Check whether the cap screws (2) are loosened.
2. Push the pre-assembled brake over the machine shaft.



Please observe the required shaft length " l_2 " acc. table in section **4.5**

3. Screw in the cap screws (17) for the brake/machine (leave approx. 5 mm stroke, see Fig. 28).
4. Adjust the output-side shrink disk hub (1) using axial movement to the installation dimension "W" acc. table in section **4.5**. We recommend an adjusted distance ring as a fixed limit stop.
5. Tighten the cap screws (2) stepwise (in 3 to max. 6 tightening sequences) and cross-wise to the tightening torque acc. table in section **4.5**.
6. Pull the brake back to contact on the screw heads (17) (fixing screws for brake/machine), then push them again against the machine (reason: release of the rotor (22)).
7. Tighten the cap screws (17) for the brake/the machine.

Installing the motor onto the brake:

8. Remove the elastomeric element (11).
9. Check whether the cap screws (6) are loosened in the input-side shrink disk hub (5).
10. Push the input-side shrink disk hub (5) onto the motor shaft, and adjust using axial movement to the installation dimension " Y_1/Y_2 " acc. table in section **4.5**. We recommend an adjusted distance ring as a fixed limit stop.



Please observe the required shaft length " l_3 " acc. table in section **4.5**

11. Tighten the cap screws (6) stepwise (in 3 to max. 6 tightening sequences) and cross-wise to the tightening torque acc. table in section **4.5**.
12. Check the installation dimension " Y_1/Y_2 " acc. table in section **4.5** and correct again if necessary.
13. Re-insert the elastomeric element (11).
14. Bring the brake and the motor into position with each other and push them together carefully. If necessary, turn the motor shaft slightly, so that the claws of the shrink disk hub (1) can be inserted into the elastomeric element (11).



Do not use force.
If necessary, release (energise) the brake if the motor cannot be inserted easily into the centering. The motor can then be moved slightly radially during joining.

15. Screw the brake and the motor together with each other using four customer-side cap screws (18) to the tightening torque acc. table in section **4.5**.

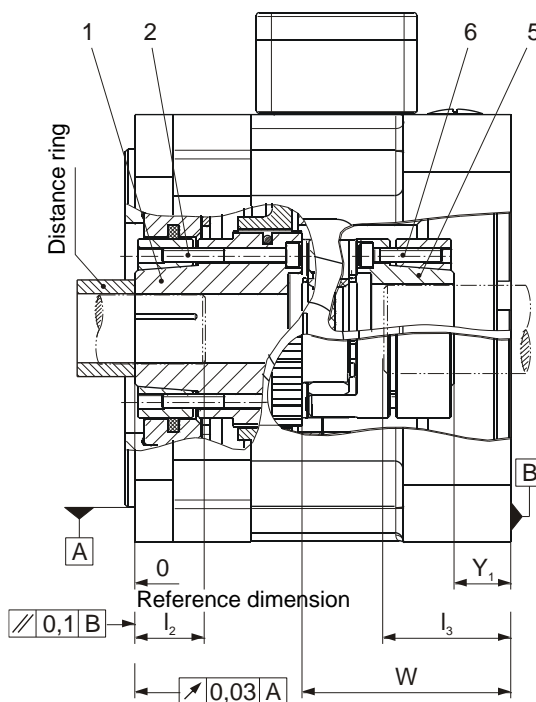

Fig. 27

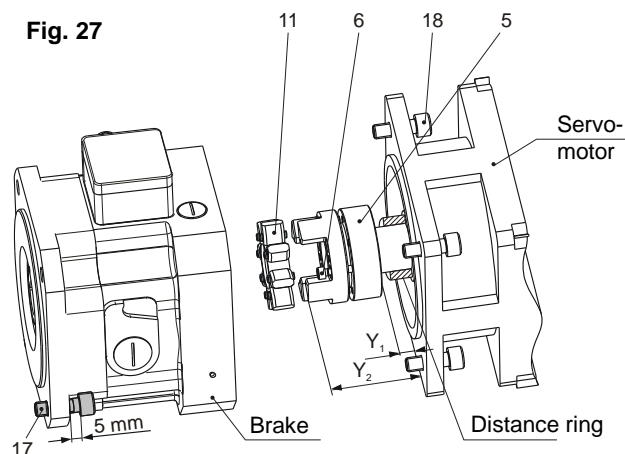

Fig. 28

10.8 Brake Type 899.100.0 _

Installing the brake onto the machine:

1. Join the shaft (7) on the output side and establish the installation dimension W_2 acc. table in section **4.5**.
2. Push the rotor (22) onto the shaft (7) toothing by hand (the rotor collar should be facing the friction flange (36)).



The rotor toothing must lie over the entire length of the shaft (7) toothing. Check that the toothing moves easily.

3. Push the pre-assembled brake over the shaft (7) and the rotor (22).
4. Tighten it using the cap screws (14) on the friction flange (36) to the tightening torque acc. table in section **4.5**.
5. Open the screw plug (16) and check the alignment of the cap screw (10) and the bore for the screw plug (16).



If necessary, energise the brake and turn the shaft (7) until the cap screw (10) is in position.

6. Adjust the shaft (7) to the installation dimension "Y" acc. table in section **4.5** and clamp it on the customer side.

Installing the motor onto the brake:

7. Check whether the cap screw (10) is loosened.
8. Push the motor (shaft) into the brake, bring it into position and tighten it to the tightening torque acc. table in section **4.5** using customer-side cap screws (18).



If necessary, release (energise) the brake if the motor cannot be inserted easily into the centering. The motor can then be moved slightly radially during joining.

Please observe the required shaft length " l_3 " and the threaded hole depth "b" acc. table in section **4.5**

9. Tighten the cap screw (10) to the tightening torque acc. table in section **4.5**.
10. Close the screw plug (16) again.

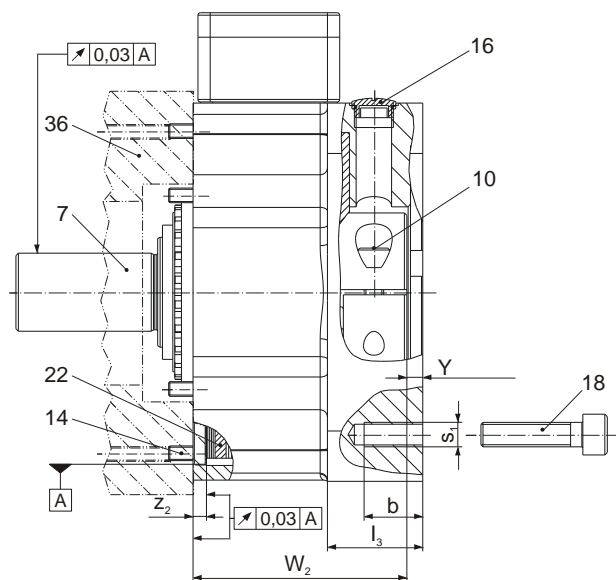

Fig. 29

10.9 Brake Type 899.111. _ _

Installing the brake onto the machine:

1. Check whether the cap screws (2) are loosened.
2. Push the output-side shrink disk hub (1) over the machine shaft and establish the installation dimension W_3 acc. table in section **4.5** (we recommend an adjusted distance ring as a fixed limit stop).



Please observe the required shaft length "I2" acc. table in section **4.5**

3. Push the rotor (22) onto the tothing of the shrink disk hub (1) by hand (the rotor collar should be facing the friction flange (36)).



The rotor tothing must lie over the entire length of the shrink disk hub (1) tothing. Check that the tothing moves easily.

4. Push the pre-assembled brake over the shrink disk hub (1) and the rotor (22) and screw them down to the tightening torque acc. table in section **4.5** onto the friction flange (36) using the eight cap screws (14).
5. Adjust the output-side shrink disk hub (1) using axial movement to the installation dimension " W/W_1 " acc. table in section **4.5**.
6. Tighten the cap screws (2) stepwise (in 3 to max. 6 tightening sequences) and cross-wise to the tightening torque acc. table in section **4.5**.

Installing the motor onto the brake:

7. Check whether the cap screw (4) is loosened in the clamping hub (3).
8. Push the clamping hub (3) with the inserted elastomeric element (11) onto the motor shaft, and adjust using axial movement to the installation dimension " Y_1/Y_2 " acc. table in section **4.5**. We recommend an adjusted distance ring as a fixed limit stop.



Minimum shaft lengthPlease observe the required minimum shaft length " I_3 " acc. table in section **4.5**

9. Tighten the cap screw (4) to the tightening torque acc. table in section **4.5**.
10. Check the installation dimension " Y_1/Y_2 " acc. table in section **4.5** and correct again if necessary.
11. Bring the brake and the motor into position with each other and push them together carefully. If necessary, turn the motor shaft slightly, so that the claws of the shrink disk hub (1) can be inserted into the elastomeric element (11).



Do not use force. If necessary, release (energise) the brake if the motor cannot be inserted easily into the centering. The motor can then be moved slightly radially during joining.

12. Screw the brake and the motor together with each other using four customer-side cap screws (18) to the tightening torque acc. table in section **4.5**.

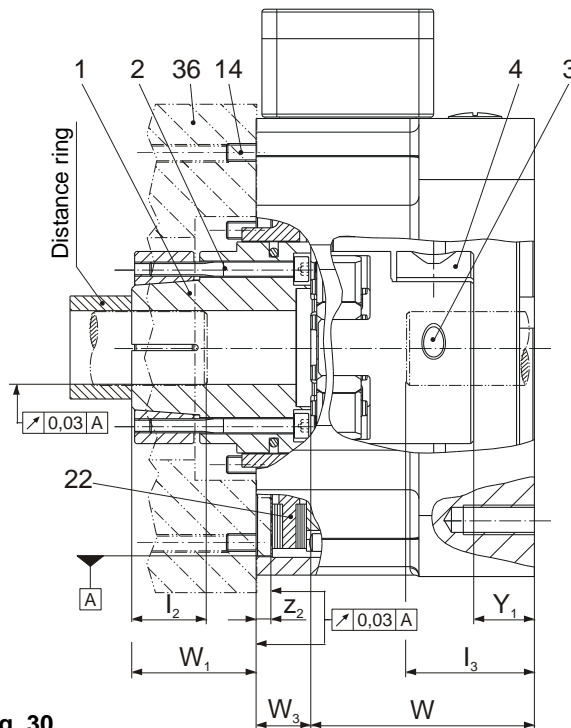

Fig. 30

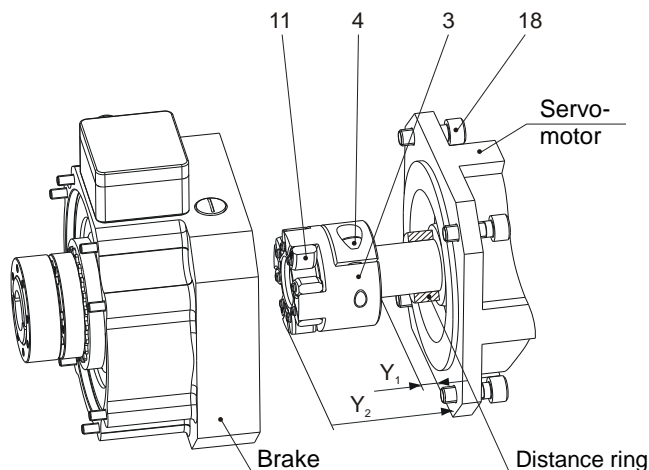

Fig. 31

10.10 Brake Type 899.112. _ _

Installing the brake onto the machine:

1. Check whether the cap screws (2) are loosened.
2. Push the output-side shrink disk hub (1) over the machine shaft and establish the installation dimension W_3 acc. table in section **4.5** (we recommend an adjusted distance ring as a fixed limit stop).



Please observe the required shaft length " I_2 " acc. table in section **4.5**

3. Push the rotor (22) onto the tothing of the shrink disk hub (1) by hand (the rotor collar should be facing the friction flange (36)).



The rotor tothing must lie over the entire length of the shrink disk hub (1) tothing. Check that the tothing moves easily.

4. Push the pre-assembled brake over the shrink disk hub (1) and the rotor (22) and screw them down to the tightening torque acc. table in section **4.5** onto the friction flange (36) using the eight cap screws (14).
5. Adjust the output-side shrink disk hub (1) using axial movement to the installation dimension " W/W_1 " acc. table in section **4.5**.
6. Tighten the cap screws (2) stepwise (in 3 to max. 6 tightening sequences) and cross-wise to the tightening torque acc. table in section **4.5**.

Installing the motor onto the brake:

7. Remove the elastomeric element (11).
8. Check whether the cap screws (6) are loosened in the input-side shrink disk hub (5).
9. Push the input-side shrink disk hub (5) onto the motor shaft, and adjust using axial movement to the installation dimension " Y_1/Y_2 " acc. table in section **4.5**. We recommend an adjusted distance ring as a fixed limit stop.



Please observe the required shaft length " I_3 " acc. table in section **4.5**

10. Tighten the cap screws (6) stepwise (in 3 to max. 6 tightening sequences) and cross-wise to the tightening torque acc. table in section **4.5**.
11. Check the installation dimension " Y_1/Y_2 " acc. table in section **4.5** and correct again if necessary.
12. Re-insert the elastomeric element (11).
13. Bring the brake and the motor into position with each other and push them together carefully. If necessary, turn the motor shaft slightly, so that the claws of the shrink disk hub (1) can be inserted into the elastomeric element (11).



Do not use force. If necessary, release (energise) the brake if the motor cannot be inserted easily into the centering. The motor can then be moved slightly radially during joining.

14. Screw the brake and the motor together with each other using four customer-side cap screws (18) to the tightening torque acc. table in section **4.5**.

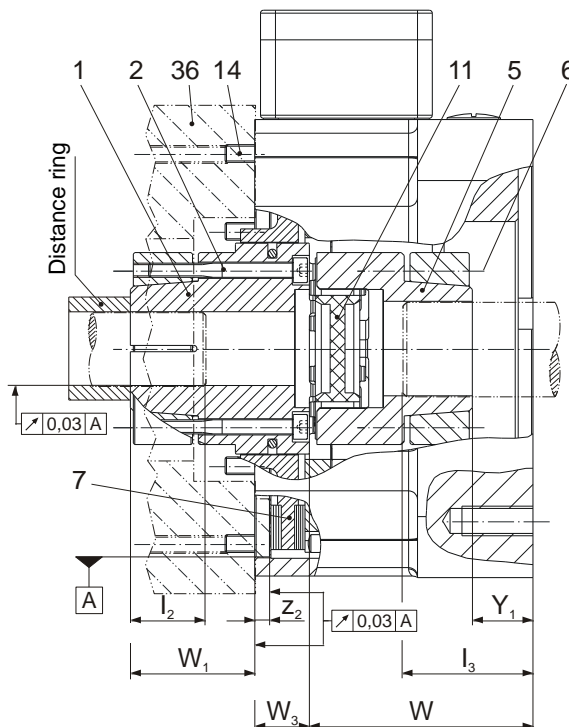

Fig. 32

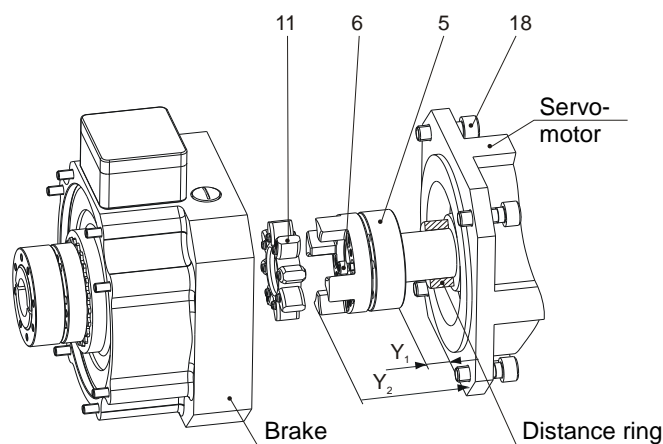

Fig. 33

10.11 Electrical connection in the terminal Box

Component examples in the terminal box (15)

- Terminal
- Release monitoring
- Plug etc.



DANGER Contact with voltage-carrying components.

Electrical shock possible.

Only trained personnel should carry out the connection.

Terminal box (15) with release monitoring (see also section 10.12)

10.11.1 Release Monitoring / Proximity Switch

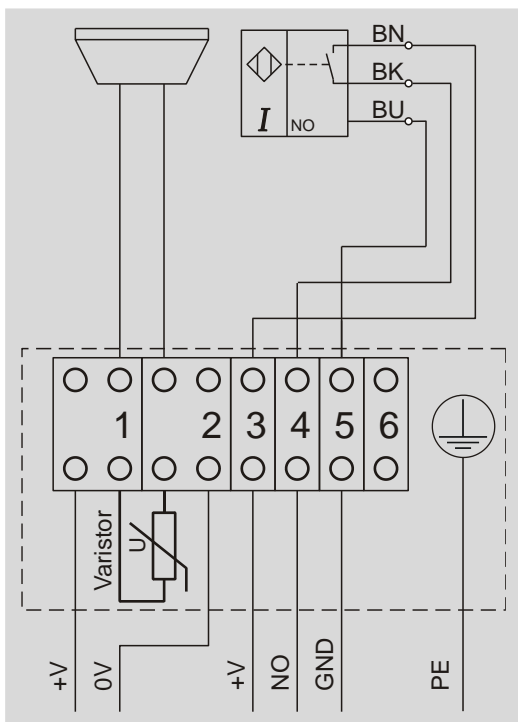

Schematic wiring diagram 6

Connect the protective conductor PE (yellow-green) with a 4 mm lug at the marked connection point.

10.11.2 Release Monitoring / Microswitch

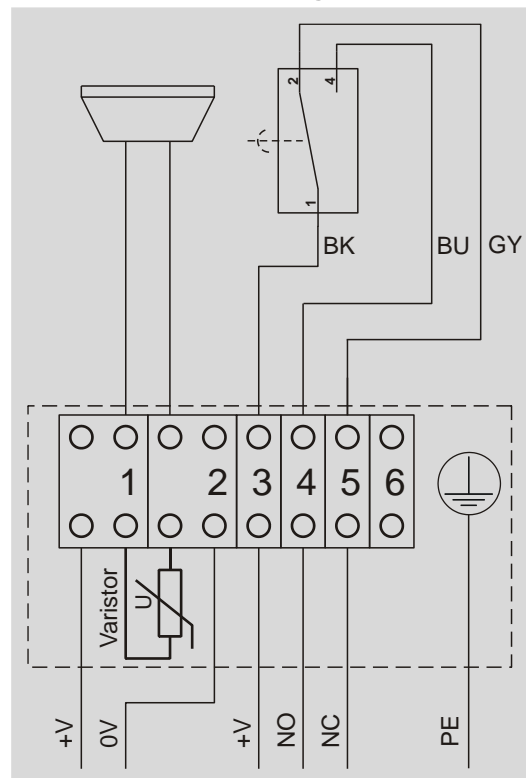

Schematic wiring diagram 7

Connect the protective conductor PE (yellow-green) with a 4 mm lug at the marked connection point.

Varistor:
Possible protection circuit manufacturer-side or customer-side as in section **7.5**

10.12 Release monitoring

10.12.1 General



Installation, adjustment and de-installation only relevant for replacement.



Proximity switches are subject to a failure rate. For the release monitoring device on ROBA®-topstop® brakes, a proximity switch with a very high reliability and a high MTBF value (Mean Time Between Failure) is used.



Microswitches cannot be guaranteed fail-safe. Therefore, please ensure appropriate access for replacement or adjustment. The switching contacts are designed so that they can be used for both small switching powers and medium ones. However, after switching a medium switching power, small switching powers are no longer reliably possible. In order to switch inductive, capacitive and non-linear loads, please use the appropriate protection circuit to protect against electric arcs and unpermitted loads!



The functional inspection with the stated dimensions only applies within a temperature range of 10 – 35 °C.

10.12.2 Release Monitoring with Proximity Switch

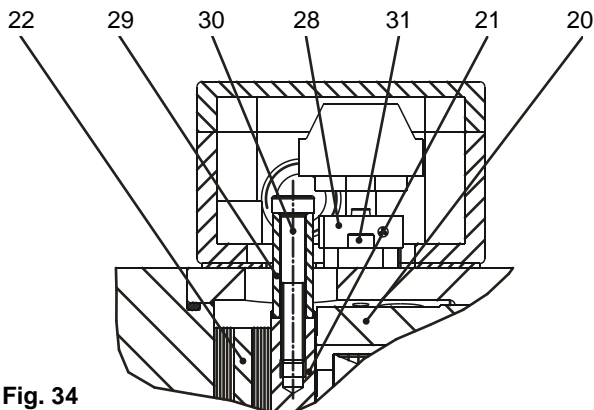

Fig. 34

ROBA®-topstop® brakes are supplied as a standard product with manufacturer-side set release monitoring.

A proximity switch (Item 28) emits a signal for every brake condition change.

Plausibility check

| | | |
|--------------|---------------------|---------------|
| Brake opened | Brake ener-gised | Signal „HIGH“ |
| Brake closed | Brake de-en-ergised | Signal „LOW“ |

The customer is responsible for a signal evaluation of both conditions (→ see **4.2.3** Release Monitoring/ Signal Evaluation).

| Technical Data | |
|--|-------------------------|
| Operating voltage: | 10... 30 VDC |
| Residual ripple content: | ≤ 10 % U _{SS} |
| DC rated operating current: | ≤ 150 mA |
| No-load current I ₀ : | ≤ 15 mA |
| Residual current: | ≤ 0.1 mA |
| Rated insulation voltage: | ≤ 0.5 kV |
| Short-circuit protection: | yes / synchro-nising |
| Line voltage drop at I _e : | ≤ 1.8 V |
| Wire breakage protection / reverse voltage protection: | yes / completely |
| Output function: | 3-wire, NO contact, PNP |
| Switching frequency: | ≤ 2 kHz |

Proximity Switch (28) Wiring Diagram:

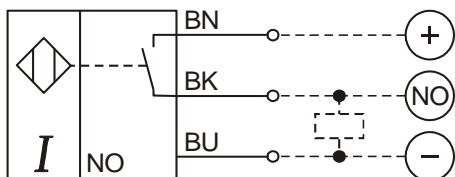

Function

When the magnetic coil is energised in the coil carrier (20), the armature disk (21) is attracted to the coil carrier (20), a proximity switch (28) emits a signal, the brake is released.

WARNING Load crash possible



On drives with gravity-loaded axes, the drive-brake must be load-free. Unless further reliable holding devices prevent lowering of the axis, the axis must be positioned in a safe, low position or supported.

WARNING Contact with voltage-carrying components.



Electrical shock possible.
De-energise the brake.

De-installation

1. Open the terminal box lid.
2. Disconnect the connection cable
3. Unscrew the cap screw (31) and remove the proximity switch (28)

Installation and adjustment (only for replacement)

4. Apply the proximity switch (28) assembly inc. the adaptor plate lightly using two cap screws (31) so that the proximity switch (28) can still be moved.
5. See the sticker on the proximity switch connection cable for the precise dimension of the adjustment plate.
6. Insert the adjustment plate between the proximity switch (28) and the switching bolt (29).
7. Press the proximity switch (28) against the adjustment plate and the switching bolt (29) and secure it using the two cap screws (31). Please observe the tightening torque of 2.9 Nm.
8. Remove the adjustment plate.
9. Mark both cap screws (31) on the screw head using sealing lacquer.

Functional Inspection

10. Connect the sensor test device (e. g. 1-1350/ Pepperl+Fuchs GmbH).
11. Insert the feeler gauge 0.15 mm between the rotor (22) and the armature disk (21) (energise the brake for a short period of time).
12. Energise the brake → Signal "HIGH"
De-energise the brake → Signal "LOW"
Remove the feeler gauge.
13. Insert the feeler gauge 0.20 mm between the rotor (22) and the armature disk (21) (energise the brake for a short period of time).
14. Energise the brake → Signal "HIGH"
De-energise the brake → Signal "HIGH"
Remove the feeler gauge.
15. Connect the brake electrically.
16. Close the terminal box with the lid.

Customer-side Inspection after Attachment

Please inspect the release monitoring:
Brake de-energised → Signal "LOW"
Brake energised → Signal "HIGH"

10.12.3 Release Monitoring with Microswitch

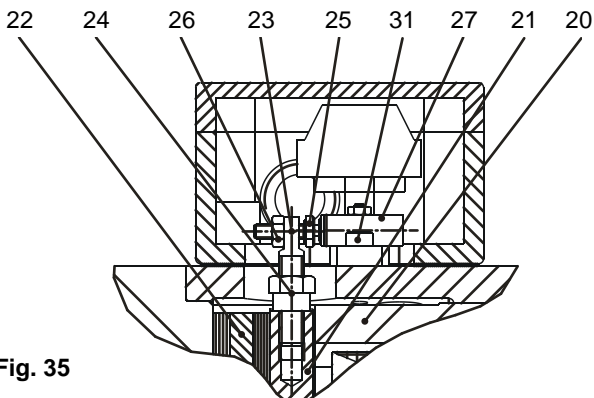

Fig. 35

ROBA®-topstop® brakes are supplied as an option with manufacturer-side set release monitoring with micro-switch.

A microswitch (Item 27) emits a signal for every brake condition change.

Plausibility check

| | | |
|--------------|---------------------|--------------|
| Brake opened | Brake ener-gised | Signal "ON" |
| Brake closed | Brake de-en-ergised | Signal "OFF" |

The customer is responsible for a signal evaluation of both conditions (→ see **4.2.3** Release Monitoring/ Signal Evaluation).

| Technical Data | |
|--|---------------------------------|
| Characteristic values for measurement: | 250 V~ / 3 A |
| Minimum switching power: | 12 V, 10 mA |
| | DC-12 |
| Recommended switching power for maximum lifetime and reliability | 24 V, 10...50 mA |
| | DC-12 |
| | DC-13 with free-wheeling diode! |

Microswitch Wiring Diagram (27):

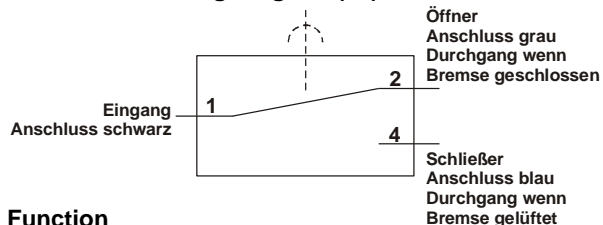

Function

When the magnetic coil is energised in the coil carrier (20), the armature disk (21) is attracted to the coil carrier (20), a microswitch (27) emits a signal, the brake is released.

Usage category acc. IEC 60947-5-1:
DC-12 (resistance load), DC-13 (inductive load)

WARNING Load crash possible



On drives with gravity-loaded axes, the drive-brake must be load-free. Unless further reliable holding devices prevent lowering of the axis, the axis must be positioned in a safe, low position or supported.

WARNING Contact with voltage-carrying components.



Electrical shock possible.
De-energise the brake.

De-installation

1. Open the terminal box lid.
2. Disconnect the connection cable
3. Remove the microswitch

Installation and adjustment (only for replacement)

4. Secure the microswitch (27) assembly with the adaptor plate in the terminal box.
5. Turn the hexagon head screw (25) in the direction of the switch (27) up to contact on the microswitch tappet.
6. Join a feeler gauge 0.15 mm (loose sensor plate) between the switch tappet (27) and the hexagon head screw (25). Please make sure that the switch tappet is straight.
7. Turn the hexagon head screw (25) in the direction of the switch (27) up to the signal "ON", turn it back to the signal "OFF", counter the hexagon head screw (25) with the hexagon nut (26) using Loctite 270.

Functional Inspection

8. Connect the inspection or measuring device (diode inspection) to the NO contact black/blue.
9. Energise the brake → Signal "ON"
De-energise the brake → Signal "OFF"
Re-adjust if necessary and repeat the inspection.
10. Inspect using feeler gauge 0.15 mm
Brake energised → Signal "ON",
Brake de-energised → Signal "OFF"
11. Inspection with feeler gauge (loose sensor plate) 0.20 mm
Brake energised → Signal "ON",
Brake de-energised → Signal "ON"
12. Connect the brake electrically.
13. Close the terminal box lid.

11 Initial Operation

11.1 Function Test

After completed assembly and electrical connection of the brake:

- Functional inspection of the proximity switch, section **10.12.2**
- Functional inspection of the microswitch, section **10.12.3**

11.2 Brake Test (Static)

Caution



During the Brake Test danger to personnel and damage to machines cannot be ruled out in case of malfunctions (incorrect installation, control errors etc.). risks to personnel and machine damage cannot be ruled out.

Do not enter the danger zone.
Possibly take measures for catching or damping the load.

11.3 Brake Test (Dynamic)



Recommendation

Determine the braking distance in a brake test during initial operation and compare it with the calculated braking distance → EN ISO 13855/EN ISO 13849-2. This test is meant to test the actual braking distance with the maximum movement speed and the respective load masses.

The determined braking distance must be shorter than the permitted overtravel path.

A brake test must ensure that, prior to reaching the hazard point, the potentially hazardous machine function is stopped. The prerequisite for this is the minimum distance between a protective assembly and a hazardous area.



Recommendation acc. the Division Information Sheet "Gravity-loaded axes – (Vertical axes)" DGUV



- For Category 2 (single-channel), a test torque of at least 1.3 times the load torque is recommended.
- If several brakes are applied in a parallel manner, (e.g. two brakes) this is considered to be fulfilled if the braking devices are tested separately one after the other on the simple weight load (= maximum loading condition).

12 Maintenance/Inspections

The rotor (22) is designed for strength and wear-resistance, which ensures a high brake service lifetime. The rotor (22) is subject to functional wear, which is dependent on the brake application conditions, e.g. it is worn by high total friction work. The brake function (release) can then no longer be guaranteed; however, the braking torque remains. The brake can be re-set to its functional state via rotor replacement.

The rotor toothing is subject to backlash and guarantees the axial displacement capability of the rotor. The rotor (22) is highly overdimensioned to prevent breakage. Due to high-frequency vibrations and impacts through the drive, the toothing may be subject to unpermittedly high wear. This can lead to breakage of the toothing and therefore to a loss of braking torque. The dangerous failure can only be revealed through a static brake test.

Caution Please observe the own weight of the brake



The brake may drop during transport / assembly. The consequences may be crush injuries and impact injuries.

For Size 260, use an eyebolt for lifting aids.

WARNING Load crash possible



The brake loses its braking torque

- During the wear inspection
- During disassembly of the brake from the machine
- When opening the shaft connection between the machine and the brake
- During energisation of the magnetic coil, e.g. for rotating the shaft
- During activation of the hand release

Unless further reliable holding devices prevent lowering of the axis, the axis must be positioned in a safe, low position or supported.

Application Test

| Measure | Condition | Interval | Implementation |
|------------------|--|---|---------------------|
| Noise inspection | After initial operation of the machine, check the idling response of the brake for particular noise generation (toothing knock-out possible) | Determine the maintenance and inspection intervals based on the results. ▶ Please contact <i>mayr</i> ®. | Qualified personnel |
| | Test the respective application for possible wear, e.g. through a type inspection. | | |

Inspection

| | | | | |
|-------------------|---|-------------------|---|---------------------|
| Visual inspection | Carry out a visual inspection of the brake from the outside for oil contamination. The brake housing should be dry on the outside. In case of heavy contamination with oil, a braking torque reduction through penetration of oil or grease cannot be ruled out. | Oil contamination | To be determined by machine operator depending on the installation situation ▶ Please contact <i>mayr</i> ®. | Qualified personnel |
| | <div style="border: 1px solid black; padding: 5px;"> <p>WARNING Load crash possible</p>  <p>In case of heavy contamination with oil, a braking torque reduction through penetration of oil or grease cannot be ruled out.</p> <p>Avoid oil contamination</p> </div> | | | |

Maintenance

| Measure | Note/comment | Interval | Implementation |
|--|---|---------------|-----------------------|
| Rotor (22) with friction lining (plastic component) without cyclical brake test | Replacement (send the brake to the manufacturer) | After 6 years | Company <i>mayr</i> ® |
| Check the shaft-hub connection or integrate it into the maintenance plan of the machine operator | Check the screw tightening torques Tightening torques see section 4.5 | Every 2 years | Qualified personnel |
| Check the fastening to the motor and machine | Check the screw tightening torques Tightening torques see section 4.5 | Every 2 years | |

13 Information on the Components

The **friction material** contains different inorganic and organic compounds, which are integrated into a system of hardened binding agents and fibres.

Possible hazards:

No potential dangers have been recognised so far when the brake is used according to its intended purpose. When conditioning of the friction lining pairing (new condition) and also in case of EMERGENCY STOP braking actions, functional wear can occur (wear on the friction linings). On open brake designs, fine dust can be emitted.

Classification: Hazardous property

Attention: H-classification: H372



13.1 Protective measures and rules of behaviour:

- Do not inhale dusts
- Vacuum the dusts at the point of origin
- Pre-requisites for the suction device**
 - tested suction devices,
 - tested filters acc. DIN EN 60335-2-69 for dust classes H;
 - maintenance of the suction devices
 - filter replacement at regular intervals
- If local dust suction is not possible or is insufficient, the entire work area must be ventilated using appropriate technology.

Additional information:

This friction lining is not a dangerous product in terms of the EC Directive

14 Cleaning the Brake



Do not clean the brake using compressed air, brushes or similar devices!

- Wear safety gloves / safety goggles
- Use a suction system or wet towels to clean off the brake dust.
- Do not inhale brake dust
 - In case of dust formation, a dust mask FFP 2 is recommended.

15 Wear Inspection



The permitted friction work values (section 5.4) dependent on the switching frequency must not be exceeded, not even in EMERGENCY STOP operation.

WARNING Load crash possible



On both variations, no braking effect is provided during the wear test. The axis must be secured against dropping.

The wear on the rotor (22) can be checked as follows:

Variant 1: Air gap

On unfavourable axial position of the rotor (22), exact determination of dimension X is not possible.

1. On the energised brake, remove one screw plug (35) positioned at the side
2. Check the dimension X between the rotor (22) and the armature disk (21) using the feeler gauge.

If the max. dimension X is exceeded (acc. table in section 4.5), rotor replacement or complete maintenance must be carried out at the **mayr**® place of manufacture.

Variant 2: Pull-in voltage

Determine the voltage at which the brake first releases. To do this, the brake must be at room temperature.

1. On the energised brake, increase the voltage slowly until the brake releases.
2. The determined pull-in voltage must not exceed the max. value acc. table in section 4.5.

If the max. pull-in voltage is exceeded, rotor replacement or complete maintenance must be carried out at the **mayr**® place of manufacture.



The voltage on the brake can be substantially lower with long lines.

If neither variant 1 nor variant 2 can be carried out, wear inspection must be carried out at the **mayr**® place of manufacture.

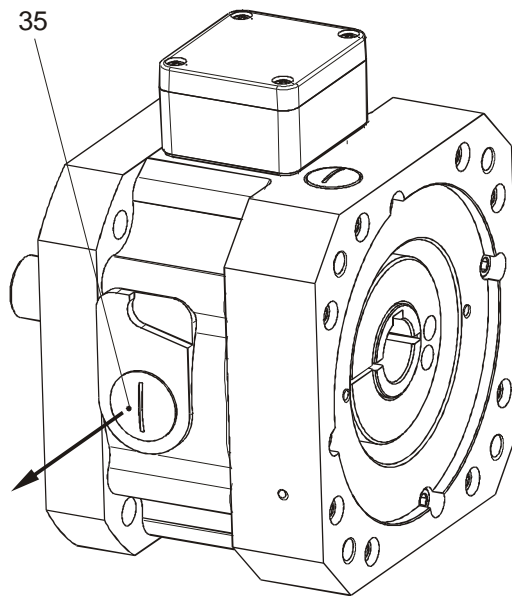

Fig. 36

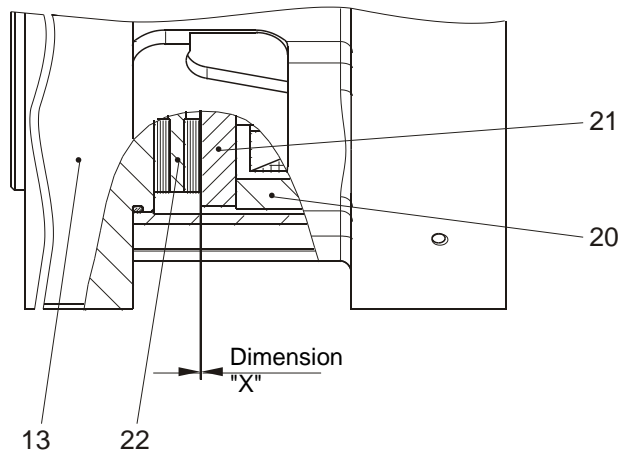

Fig. 37

16 De-installation

CAUTION Please observe the own weight of the brake



The brake may drop during lifting / disassembly. The consequences may be crush injuries and impact injuries.

For Size 260, use an eyebolt for lifting aids.

WARNING Load crash possible



The brake must be load-free.

Please check that it is load-free before de-installation.

- Provide security in the danger zone
- Support the load

Danger Contact with voltage-carrying components.



Electrical shock possible.

Only trained personnel may disconnect the electrical connection.

De-installation takes place by following the "Installation" section **10** backwards.

17 Disposal

Our electromagnetic brake components must be disposed of separately as they consist of different materials. Please also observe the relevant authority regulations. Code numbers may vary according to the disassembling process (metal, plastic and cables).

Electronic components

(Rectifier / ROBA®-switch / Microswitch):

Products which have not been disassembled can be disposed of under Code No. 160214 (mixed materials) or components under Code No. 160216, or can be disposed of by a certified disposal firm.

Brake bodies made of steel pads with coil /cable and all other steel components:

Steel scrap (Code No. 160117)

All aluminium components:

Non-ferrous metals (Code No. 160118)

Brake rotor (steel or aluminium pads with friction linings):

Brake linings (Code No. 160112)

Seals, O-rings, V-seals, elastomers:

Plastic (Code No. 160119)

18 Malfunctions / Breakdowns

| Malfunction | Result of Malfunction | Possible Causes | Solutions | Implementation |
|---|---|--|---|-----------------------|
| | | | <input type="checkbox"/> The brake must always be dismantled in order to remove damage and malfunctions. <input type="checkbox"/> Damaged parts must be replaced in order to solve the respective problem. <input type="checkbox"/> The brake must be cleaned before re-installation. | |
| Brake does not release | Wiring error on the brake | Incorrect voltage, no DC voltage | Check voltage, observe the wiring guidelines | Qualified personnel |
| | | Defective electrical wiring | Check electrical wiring | |
| | | Defective coil, coil is thermally overloaded | Check coil capacity, check insulation resistance | |
| | Air gap too large in released condition | Worn rotor | Replace rotor or brake | Company <i>mayr</i> ® |
| The brake does not release completely; permanent grinding of the rotor | Wiring error on the brake | Incorrect voltage, no DC voltage | Check voltage, observe the wiring guidelines | Qualified personnel |
| | | Defective electrical wiring | Check electrical wiring | |
| | | Defective coil, coil is thermally overloaded | Check coil capacity, Check insulation resistance | |
| | Air gap too small in unreleased condition | Penetration of foreign bodies into the brake, in particular magnetisable particles | Check the brake interior for dirt and clean it | Company <i>mayr</i> ® |
| | | Excessive component temperatures, temperature expansion | Temperature inspection | Qualified personnel |

Operational Instructions for ROBA®-topstop® Type 899. _ _ _ . _ _ _ Sizes 100 - 260

(B.8.8.EN)

| Malfunction | Result of Malfunction | Possible Causes | Solutions | Implementation |
|--|--------------------------------------|---|---|-----------------------|
| | | | <input type="checkbox"/> The brake must always be dismantled in order to remove damage and malfunctions. <input type="checkbox"/> Damaged parts must be replaced in order to solve the respective problem. <input type="checkbox"/> The brake must be cleaned before re-installation. | |
| Slipping; permanent grinding of the brake under load; increase in friction work | Braking torque too low | Incorrect dimensioning | Check the required braking torque | Qualified personnel |
| | Drop in braking torque | Excessive wear on the rotor | Wear inspection (see section 15) | |
| | Changes in braking torque | Unpermittedly high friction work, squeaking, type and quality of the counter friction surface | Optimise the electrical control, check the switching times and dimensioning | |
| | | Corrosion on the counter friction surface | Check the brake for corrosion | |
| | | Ambient influences, oil, water, cleaning media, condensation formation | Check protection against environmental influences | |
| | Excessively long engagement times | Load accelerates the drive line during the brake engagement time | Optimise the electrical control; check the switching times and dimensioning | |
| | Motor starts up against closed brake | Excessive brake separation times | Optimise the electrical control; check the switching times and dimensioning, check the motor control | |
| | Loss of spring force | Wire breakage of the spring | Replace the spring | Company <i>mayr</i> ® |
| Component breakage | Operating conditions | Oscillations, vibrations, overload, unpermittedly high speeds | Check operating conditions and dimensioning | Qualified personnel |



mayr® will take no responsibility or guarantee for replacement parts and accessories which have not been delivered by *mayr*®, or for damage resulting from the use of these products.

19 Declaration of Conformity

EC – Declaration of Conformity

TRANSLATION

In terms of the EC Directive 2006/42/EC (machinery directive) relating to machinery we

Chr. Mayr GmbH + Co. KG
Eichenstraße 1
D-87665 Mauerstetten

declare that the products stated below have been developed, constructed and manufactured in sole responsibility and in conformity with the above mentioned EC Directive.

Electromagnetic spring applied brakes

| Product | Sizes | Types | ASRI |
|----------------|-----------|--------------------|-------------------------|
| ROBA®-topstop® | 100 - 260 | 899. _ _ _ . _ _ _ | 1,2,3,4,5,6,7, *,*** |

Year of manufacture: see product label

Applied Standards, Regulations and Inspections (ANVP)

| | | | | |
|---|--------------------|---------|--|------------|
| 1 | DIN VDE 0580 | 11/2011 | Electromagnetic devices and components, general specifications | 2014/35/EU |
| 2 | DIN EN ISO 12100 | 03/2011 | Safety of machinery - General principles for design | 2006/42/EG |
| 3 | EN 60204-1 | 06/2007 | Safety of machinery – Electrical equipment of machines | 2006/42/EG |
| 4 | DIN EN ISO 13849-1 | 12/2008 | Safety of machinery – Safety related parts of control systems | 2006/42/EG |
| 5 | DIN EN ISO 13849-2 | 06/2010 | Safety of machinery – Safety related parts of control systems | 2006/42/EG |
| 6 | DIN EN 61000-6-2 | 03/2006 | Electromagnetic compatibility, Immunity for industrial environments | 2014/30/EU |
| 7 | DIN EN 61000-6-4 | 09/2007 | Electromagnetic compatibility, Emission standard for industrial environments | 2014/30/EU |

The safety of our customers and machinery operators is important for the company Chr. Mayr GmbH + Co. KG. Therefore the product size 200 has been additionally tested by an independent certification body DGUV Test, identification number MF13001. According to “Principles of testing and certification of emergency brake systems with holding force function for linear movement”

| | |
|---|--|
| X | * EC-Machinery directive 2006/42/EC |
| | ** EU-Low voltage directive 2014/35/EU (is covered by the machinery directive) |
| | *** Electromagnetic compatibility directive 2014/30/EU |

Representatives name for the documentation: Quality Management

Mauerstetten, March 08, 2016
 Ort und Datum / place and date

Dipl. Ing. (FH) / graduate engineer
 Geschäftsführer / Managing Director
 Günther Klingler