

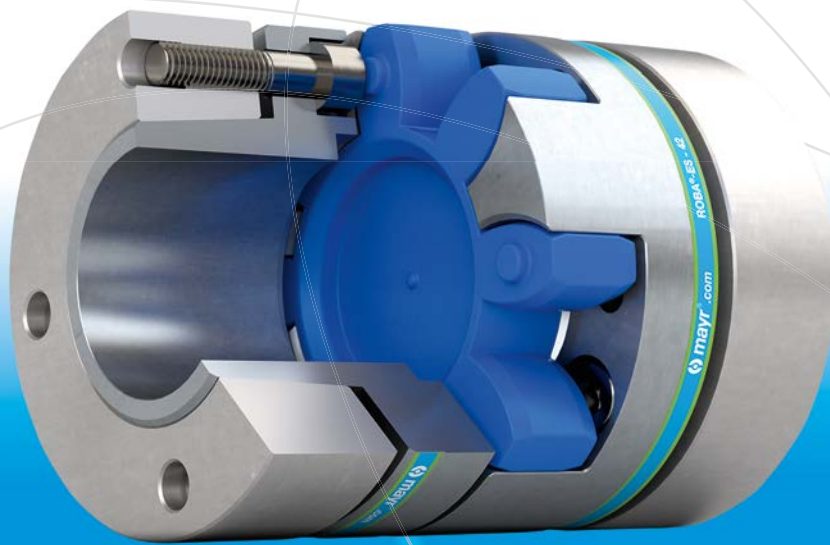

your reliable partner



ROBA[®]-ES

We safeguard the movements of this world



The Christian Mayr mill-construction business – founded in 1897.

Specialists for power transmission for more than a century

mayr[®] power transmission is one of the most traditional and yet most innovative German companies in the field of power transmission. From modest beginnings in the year 1897, the family enterprise from the Allgäu region has developed into world market leader. Today, 600 employees work at the headquarters in Mauerstetten; more than 1000 employees work for the company worldwide.

Unsurpassed standard product range

mayr[®] power transmission offers an extensive variety of torque limiters, safety brakes, backlash-free shaft misalignment compensation couplings and high-quality DC drives. Also when it comes to customer-specific requirements, the company possesses the expertise to develop customized and economical solutions. This is why numerous renowned machine manufacturers trust in holistic solutions by *mayr*[®] power transmission.

Represented worldwide

With eight subsidiaries in Germany, sales offices in the USA, France, Great Britain, Italy, Singapore and Switzerland as well as 36 additional country representatives, *mayr*[®] is available in all important industrial areas, guaranteeing optimum customer service around the globe.

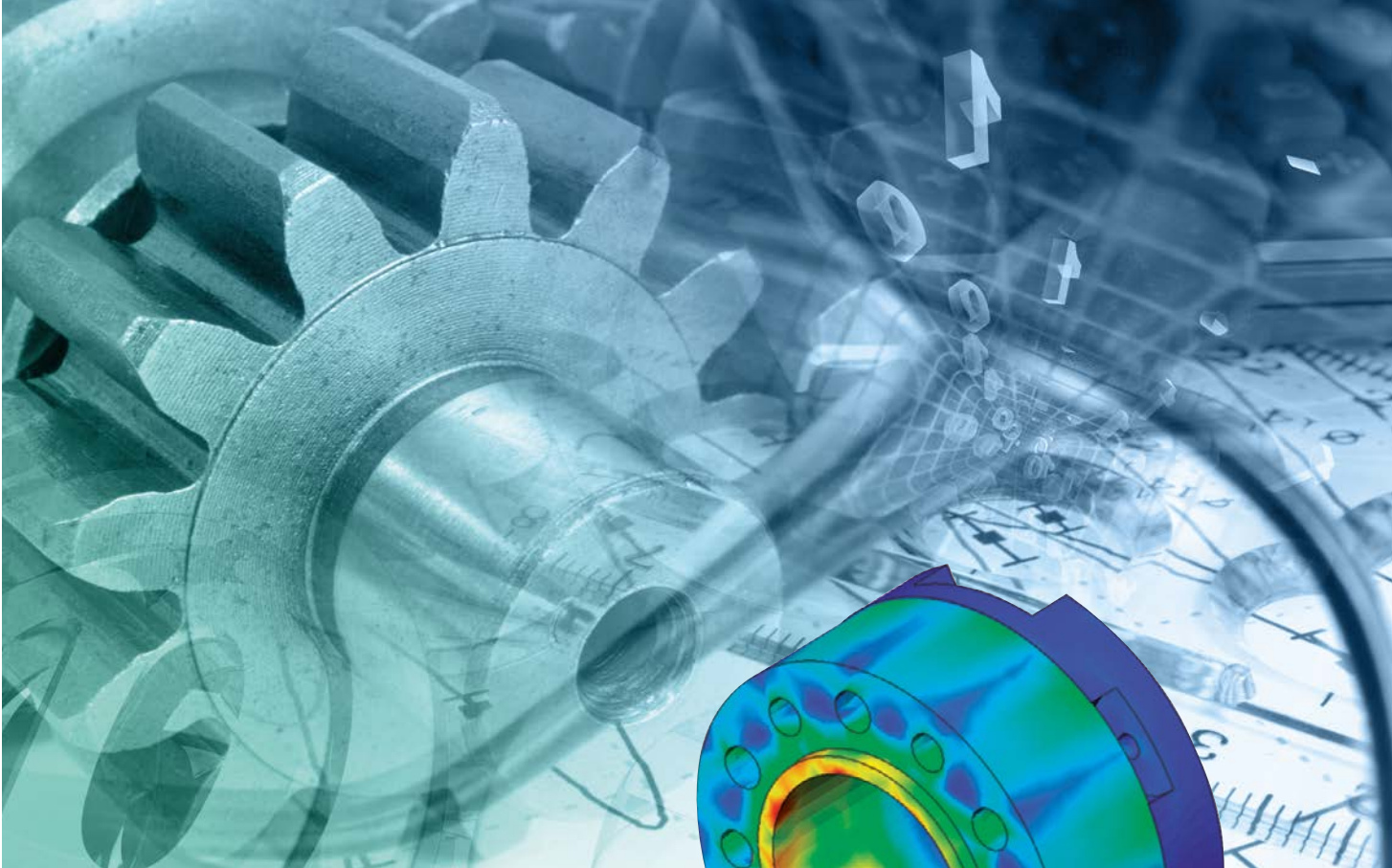

Tradition and innovation – the best of both worlds

Tradition and innovation do not contradict each other - on the contrary. They are the two supporting pillars which have guaranteed stability and reliability for generations. Long-term stability, independence as well as a good reputation and satisfied customers are important values for a family enterprise rich in tradition.

Therefore, we place emphasis on:

- Tested product quality,
- Optimum customer service,
- Comprehensive know-how,
- Global presence,
- Successful innovations and
- Effective cost management.

Following our own objective of always offering our customers the technologically most advanced and most economical solution, we have been able to gain the trust of many leading industrial companies from all branches and from all over the world as a reliable partner.

Place your trust in our know-how and our more than 50 years of experience in the areas of torque limiters, safety brakes and shaft couplings.

ROBA[®]-ES

Backlash-free elastomer coupling

- **Vibration damping**
- **Damping behaviour can be selected through elastomeric elements in different Shore hardnesses**
- **Backlash-free torque transmission through pre-tensioned elastomeric element**
- **Compensation of shaft misalignments**
- **Plug-in connection, therefore suitable for blind assembly**
- **Maintenance-free, media-resistant, temperature-stable**
- **Torsionally flexible on a small scale, but two to four times more rigid than toothed belt drives**

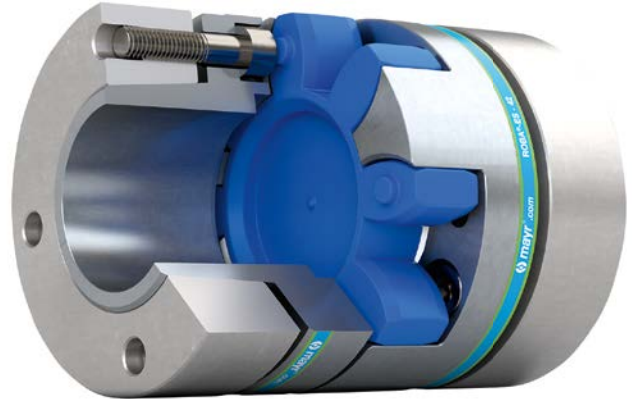

ROBA[®]-ES Elastomeric Elements

The elastomeric elements are the central element of the ROBA[®]-ES-coupling. They define the application range as well as the shaft connection behaviour via the permitted torque, the rigidity, the damping and the misalignment values.

By using a unique polyurethane material and a special injection procedure, it is possible to achieve a high dimensional accuracy and evenness in the teeth of the elastomeric element.

The elastomeric elements are available in different shore hardnesses. The teeth of the elastomeric element are chamfered at the sides. This makes blind assembly easier.

The ambient temperatures present during operation have a considerable effect on the dimensioning of a ROBA[®]-ES-coupling (see Dimensioning page 22).



Dimensioning

The characteristics of ROBA[®]-ES couplings can be greatly varied by using different elastomeric elements. Due to different damping characteristics and the non-linear rigidity of the elastomer, this element also offers more parameters than the steel shaft connection, which should be taken into account on selection.

We therefore recommend careful, thorough coupling dimensioning (see Dimensioning page 22).

Agent Resistance

The elastomeric elements are very resistant against

- pure mineral oils (lubricating oils)
 - and anhydrous greases.
- They have a similar resistance against fuels such as
- regular-grade petroleum
 - diesel oil
 - kerosene.
- Damage may occur after longer exposure to
- alcohols or
 - aromatic fuels (super/four star petrol).

The elastomeric element material used is resistant to hydrolysis. In contrast to other polyurethane materials, water (including sea water) causes, even after years of exposure, no particular changes to the mechanical characteristics. Hot water, however, reduces the mechanical strength.



ROBA[®]-ES couplings are also available in ATEX design according to the directive 2014/34/EU.

ROBA®-ES Contents

Designs

ROBA®-ES with key hubs

- Single-jointed coupling
- Double-jointed coupling short
- Double-jointed coupling with sleeve

ROBA®-ES couplings are delivered as un-bored hub design (further processing to be carried out customer-side) or with a finish bore and keyway JS9 (DIN 6885/1). An adjusting screw is located in the hub for axial securement.

Up to Size 38, the hubs are made of aluminium. From Size 42, they are made of steel.

Conventional bores can be delivered from stock.

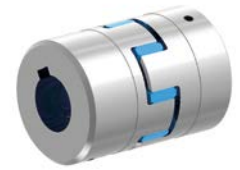

Page 8

ROBA®-ES with clamping hubs

- Single-jointed coupling
- Double-jointed coupling short
- Double-jointed coupling with sleeve

ROBA®-ES couplings with clamping hubs are conceived for fast and safe installation or de-installation. They have no keyway. The tightening torque (T_A) on the clamping screws must be maintained in order to ensure reliable, frictionally-locking torque transmission.

Please observe the maximum permitted torques (page 28).

Up to Size 38, the hubs are made of aluminium. From Size 42, they are made of steel.

The clamping hub can be designed with an additional keyway on request.



Page 10

ROBA®-ES with clamping hubs Compact

- Single-jointed coupling
- Double-jointed coupling short
- Double-jointed coupling with sleeve

ROBA®-ES couplings with clamping hubs are conceived for fast and safe installation or de-installation. They have no keyway. The tightening torque (T_A) on the clamping screws must be maintained in order to ensure reliable, frictionally-locking torque transmission.

Please observe the maximum permitted torques (page 28).

The hubs are made of aluminium. The clamping hub can be designed with an additional keyway on request.

Due to the compact construction of the short clamping hubs, the couplings can be used in constricted installation conditions



Page 12

ROBA®-ES with split clamping hubs

- Single-jointed coupling
- Double-jointed coupling short
- Double-jointed coupling with sleeve

ROBA®-ES couplings with split clamping hubs are conceived for fast and safe installation or de-installation. Due to the orientation of the half-shells in the same direction, radial assembly/disassembly of the coupling is possible at stationary shaft ends. The tightening torque (T_A) on the clamping screws must be maintained in order to ensure reliable, frictionally-locking torque transmission.

Please observe the maximum permitted torques (page 29).

Up to Size 38, the hubs are made of aluminium. From Size 42, they are made of steel. The split clamping hub can be designed with an additional keyway on request.



Page 14

ROBA[®]-ES with aluminium shrink disk hubs

- Single-jointed coupling
- Double-jointed coupling short

On this design, the hub body is made of aluminium and the ring of phosphated, annealed steel. The design is constructionally identical to the P-design (page 19). The symmetry, the absence of keyways and radial bores produces an optimum shaft run-out. Therefore, much higher speeds are possible compared to the other hub designs (please observe Diagram 1 “Balancing the shrink disk hub”, page 31).

The torque is transmitted via frictional locking onto the shaft.

Please observe the maximum permitted torques (page 27).



Page 16

ROBA[®]-ES with steel shrink disk hubs

- Single-jointed coupling
- Double-jointed coupling short

On this design, the hub body is made of steel (oiled) and the ring of phosphated, annealed steel. This design is available in a standard variant and a variant according to DIN 69002. The DIN variant has an elastomeric element with a central, standardised bore and standardised bore diameters in the hubs. The DIN variant is conceived for use in short bore spindles and multi-spindle heads. Because of the steel hubs, this DIN design combines robustness with precision. This design should be selected in preference to others, in particular on applications with heavily pulsating or alternating loads.

Please observe the maximum permitted torques (page 27).



Page 18

ROBA[®]-ES with Expansion hub and Clamping hub

- Single-jointed coupling

ROBA[®]-ES couplings with an expansion hub have been designed for frictionally-locking torque transmission onto hollow shafts. The expansion hubs are combined with clamping hubs on the opposite side as a standard measure. Other combinations with other hubs are conceivable.

The stated diameters of the expansion hubs are preferred dimensions.

Other diameters can be requested at *mayr*[®] power transmission.

Please observe the maximum permitted torques (page 29).



Page 20

Coupling Dimensioning

Page 22 ▷

Technical Explanations

Page 24 ▷

Technical Explanations (transmittable torques)

Page 27 ▷

ROBA®-ES elastomer couplings Type 94_._._

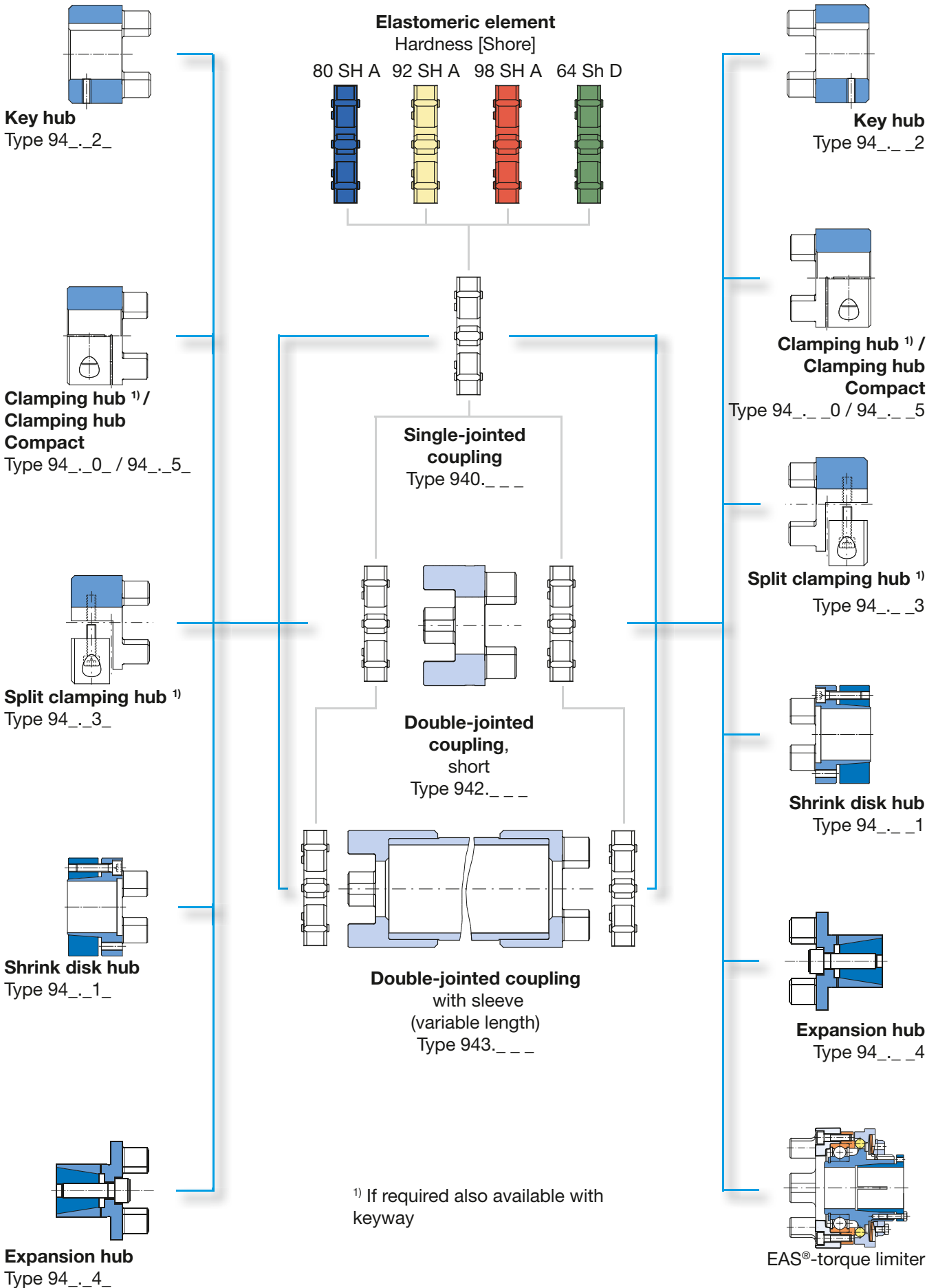

ROBA®-ES with key hubs

Sizes 14 to 65

Single-jointed coupling / Type 940._ 22._

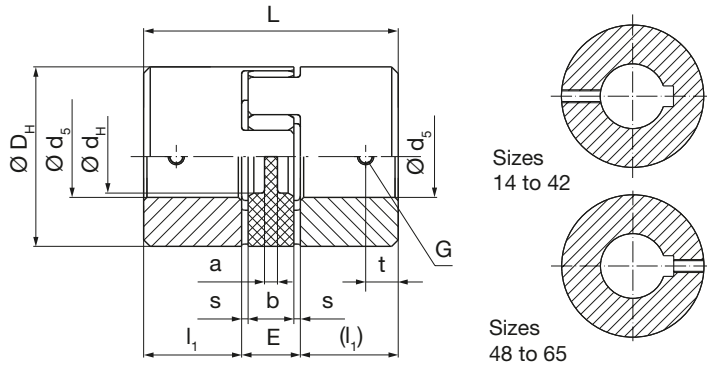

The adjusting screw is offset by 180° to the keyway on Sizes 14 to 42 (see Fig. above).

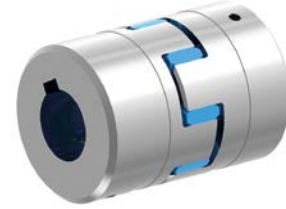

Technical Data and Main Dimensions			Size								
			14	19	24	28	38	42	48	55	65
Minimum hub bore ^{1) 2)}	$d_5^{H7}_{min}$	[mm]	6	6	8	10	12	14	20	20	38
Maximum hub bore ^{1) 2)}	$d_5^{H7}_{max}$	[mm]	15	24	28	38	45	55	60	70	80
Maximum speed ^{3) 4)}	n_{max}	[rpm]	19000	14000	10600	8500	7100	6000	5600	5000	4600

Mass moments of inertia J [10⁻³ kgm²] ^{5) 6)}

	Size	14	19	24	28	38	42	48	55	65
Elastomeric element		0.0005	0.0012	0.0067	0.0154	0.042	0.09	0.143	0.248	0.474
Key hub		0.0026	0.0175	0.0781	0.169	0.498	3.093	5.173	10.096	18.524
Single-jointed coupling short		0.0057	0.0362	0.1629	0.3534	55	6.276	10.489	20.44	37.522
Sleeve with $H_s = 1000$ mm		0.075	0.27	0.74	1.33	2.42	14.33	29.7	48.94	71.43
Sleeve with 1000 mm tube		0.071	0.236	0.676	1.202	1.917	10.676	24.89	41.167	54.082

Weights [kg] ^{5) 6)}

	Size	14	19	24	28	38	42	48	55	65
Elastomeric element		0.0048	0.007	0.019	0.037	0.054	0.081	0.104	0.149	0.216
Key hub		0.018	0.064	0.161	0.236	0.47	2.03	2.792	4.136	5.95
Single-jointed coupling short		0.041	0.135	0.341	0.509	0.994	4.141	5.688	8.421	12.116
Sleeve with $H_s = 1000$ mm		0.595	1.036	1.323	1.631	2.101	9.429	15.764	18.009	21.351
Sleeve with 1000 mm tube		0.574	0.86	1.22	1.477	1.705	7.383	13.561	15.193	16.622

Dimensions	Size									
	14	19	24	28	38	42	48	55	65	
a	2	4	4	5	5	5	5	9	8	
b	10	12	14	15	18	20	21	22	26	
D_H	30	40	55	65	80	95	105	120	135	
d_H	10.5	18	27	30	38	46	51	60	68	
E	13	16	18	20	24	26	28	30	35	
G	M4	M5	M5	M6	M8	M8	M8	M10	M10	
L	35	66	78	90	114	126	140	160	185	
L_2	56	92	112	128	158	174	192	218	252	
L_3	dependent on H_s									
l_1	11	25	30	35	45	50	56	65	75	
l_2	34	42	52	58	68	74	80	88	102	
$H_{s,min}$	68	87	101	115	143	162	178	200	230	
$H_{s,max}$	2000	2000	2000	2000	2000	2000	2000	3000	3000	
s	1.5	2.0	2.0	2.5	3.0	3.0	3.5	4.0	4.5	
t	5	10	10	15	15	20	25	20	20	

We reserve the right to make dimensional and constructional alterations.

Stock program	Size				
	14	19	24	28	38
Bore					
Ø6					
Ø8	x				
Ø9					
Ø10	x	x			
Ø11	x				
Ø12	x	x			
Ø14	x	x	x		
Ø15		x	x		
Ø16		x	x		
Ø17					
Ø18		x	x		
Ø19		x	x	x	
Ø20		x	x	x	x
Ø22				x	
Ø24			x	x	
Ø25			x	x	x
Ø28				x	
Ø30				x	x
Ø32				x	x
Ø35					x
Ø38					x

ROBA[®]-ES with key hubs

Sizes 14 to 65

Double-jointed coupling short / Type 942._ 22._

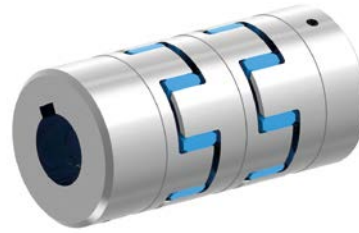
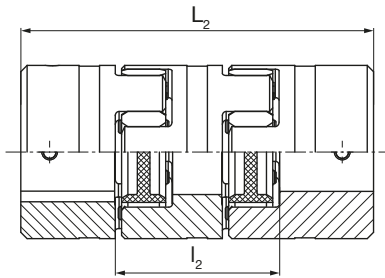

Double-jointed coupling with sleeve / Type 943._ 22._

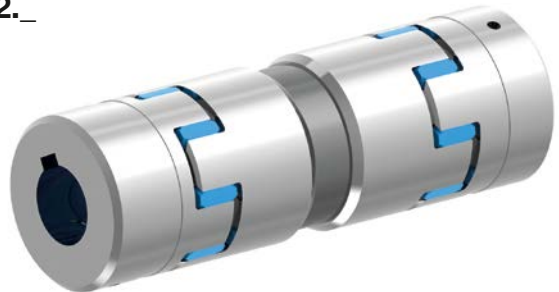
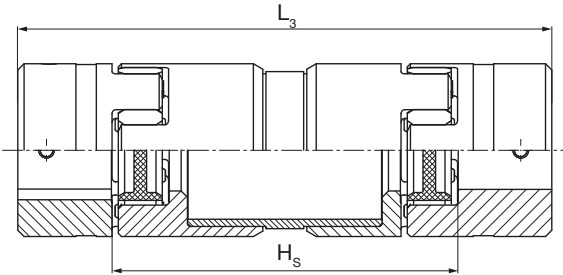

Order Number

				0 Single-jointed coupling 2 Double-jointed coupling short 3 Double-jointed coupling with sleeve		Sleeve length H _s [mm]		
_ / 9 4 _ . _ 2 2 . _ / _ / _ / _ / _				▽		▽		
△		△		△	△	△	△	△
Size 14 to 65 ⁷⁾	Elastomeric element hardness	98 Sh A (red) 92 Sh A (yellow) 80 Sh A (blue) 64 Sh D (green)	0 1 5 6	Aluminium design up to Size 38 Steel design from Size 42	A F	Bore ø d₅^{H7} (see Table)	Bore ø d₅^{H7} (see Table)	Operating speed n_s [rpm] for sleeve

Example: 42 / 940.022.F / Ød₅ 30 / Ød₅ 30

- 1) Recommended hub / shaft tolerance: H7 / k6
- 2) In order to dimension the shaft-hub connection, the calculation procedure acc. DIN 6892 is to be applied. For the calculation, please take the yield point Rp 0.2 = 200 N/mm² for aluminium and the yield strength Re = 350 N/mm² for steel.
- 3) Also applicable for double-jointed design
- 4) Not valid for designs with sleeve (see diagram: "Permitted speeds for sleeve" on page 26)
- 5) Mass moments of inertia and weights are valid for one elastomeric element
- 6) Mass moments of inertia and weights are valid for maximum bore
- 7) Further Sizes available on request

ROBA®-ES with clamping hubs

Sizes 14 to 65

Single-jointed coupling / Type 940._ 00._

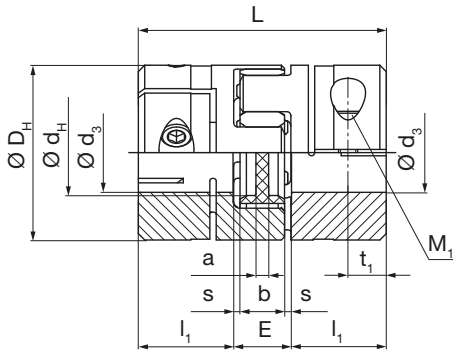

Technical Data and Main Dimensions			Size								
			14	19	24	28	38	42	48	55	65
Minimum hub bore ^{1) 2)}	$d_3^{F7}_{min}$	[mm]	6	10	15	19	20	28	35	40	45
Maximum hub bore ^{1) 2)}	$d_3^{F7}_{max}$	[mm]	15	20	28	35	45	50	55	70	80
Maximum speed ^{3) 4)}	n_{max}	[rpm]	12600	9300	7000	5600	4700	4000	3700	3300	3000
Tightening torque clamping screws	T_A	[Nm]	1.4	10	10	25	25	70	120	120	200

Mass moments of inertia J [10⁻³ kgm²] ^{5) 6)}

	Size	14	19	24	28	38	42	48	55	65
Elastomeric element		0.0005	0.0012	0.0067	0.0154	0.042	0.09	0.143	0.248	0.474
Clamping hub		0.0028	0.0193	0.076	0.168	0.481	3.104	5.176	9.742	17.985
Single-jointed coupling short		0.0061	0.0398	0.1587	0.3514	1.004	6.298	10.495	19.732	36.444
Sleeve with $H_s = 1000$ mm		0.075	0.27	0.74	1.33	2.42	14.33	29.7	48.94	71.43
Sleeve with 1000 mm tube		0.071	0.236	0.676	1.202	1.917	10.676	24.89	41.167	54.082

Weights [kg] ^{5) 6)}

	Size	14	19	24	28	38	42	48	55	65
Elastomeric element		0.0048	0.007	0.019	0.037	0.054	0.081	0.104	0.149	0.216
Clamping hub		0.02	0.077	0.159	0.245	0.456	2.134	2.922	4.021	5.818
Single-jointed coupling short		0.0448	0.161	0.337	0.527	0.966	4.349	5.948	8.191	11.852
Sleeve with $H_s = 1000$ mm		0.595	1.036	1.323	1.631	2.101	9.429	15.764	18.009	21.351
Sleeve with 1000 mm tube		0.574	0.86	1.22	1.477	1.705	7.383	13.561	15.193	16.622

Dimensions	Size									
	14	19	24	28	38	42	48	55	65	
a	2	3	4	5	6	6	5	9	8	
b	10	12	14	15	18	20	21	22	26	
D_H	30	40	55	65	80	95	105	120	135	
D_K	32.2	47	56.4	72.6	83.3	98.8	108	122	139	
d_H	10.5	18	27	30	38.5	46	51	60	68	
E	13	16	18	20	24	26	28	30	35	
L	35	66	78	90	114	126	140	160	185	
L_2	56	92	112	128	158	174	192	218	252	
L_3	dependent on H_s									
l_1	11	25	30	35	45	50	56	65	75	
l_2	34	42	52	58	68	74	80	88	102	
$H_{s,min}$	68	87	101	115	143	162	178	200	230	
$H_{s,max}$	2000	2000	2000	2000	2000	2000	2000	3000	3000	
M_1	M3	M6	M6	M8	M8	M10	M12	M12	M14	
s	1.5	2	2	2.5	3	3	3.5	4	4.5	
t_1	5.5	12	12	13.5	20	20	21	26	27.5	
t_2	11	14	20	24	30	34	36	45	52	

We reserve the right to make dimensional and constructional alterations.

Stock program	Size					
	Bore	14	19	24	28	38
Ø6						
Ø7						
Ø8	x					
Ø9	x					
Ø10	x	x				
Ø11	x	x				
Ø12	x	x				
Ø14	x	x				
Ø15	x	x	x			
Ø16		x	x			
Ø17						
Ø18			x			
Ø19			x	x		
Ø20			x	x		
Ø22			x	x		
Ø24			x	x		
Ø25			x	x	x	
Ø28			x	x		
Ø30				x		
Ø32				x	x	
Ø35					x	
Ø38						x
Ø40						x

ROBA[®]-ES with clamping hubs

Sizes 14 to 65

Double-jointed coupling short / Type 942._00._

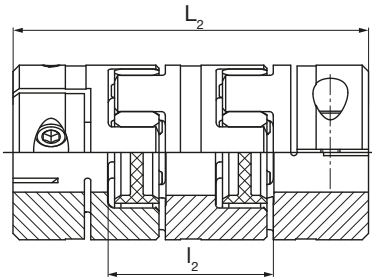

Double-jointed coupling with sleeve / Type 943._00._

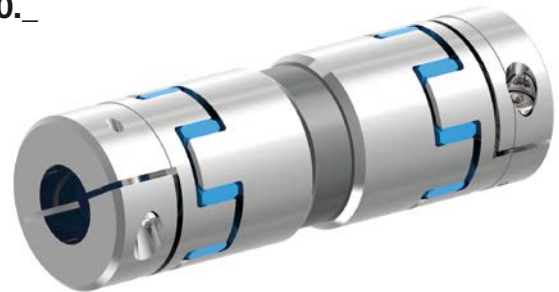
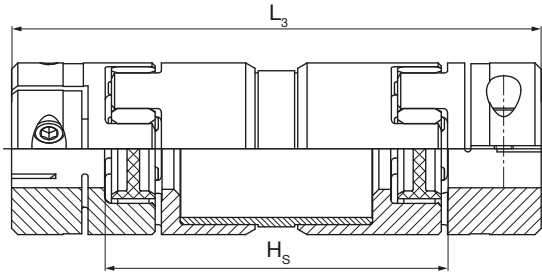

Order Number

- 0 Single-jointed coupling
- 2 Double-jointed coupling short
- 3 Double-jointed coupling with sleeve

Sleeve length
 H_s [mm]

Order Number		Coupling Type		Material		Bore		Operating speed	
Size	Elastomeric element hardness	98 Sh A (red)	0	Aluminium design up to Size 38	A	Bore $\varnothing d_3^{F7}$ (see Table)	Bore $\varnothing d_3^{F7}$ (see Table)	Operating speed n_s [rpm]	for sleeve
14		92 Sh A (yellow)	1	Steel design from Size 42	F				
to 65 ⁷⁾		80 Sh A (blue)	5						
		64 Sh D (green)	6						

Example: 42 / 940.000.F / $\varnothing d_3$ 30 / $\varnothing d_3$ 30

- 1) Recommended hub / shaft tolerance: F7 / k6
- 2) Transmittable torques dependent on bore, see page 28.
- 3) Also applicable for double-jointed design
- 4) Not valid for designs with sleeve (see diagram: "Permitted speeds for sleeve" on page 26)
- 5) Mass moments of inertia and weights are valid for one elastomeric element
- 6) Mass moments of inertia and weights are valid for maximum bore
- 7) Further Sizes available on request

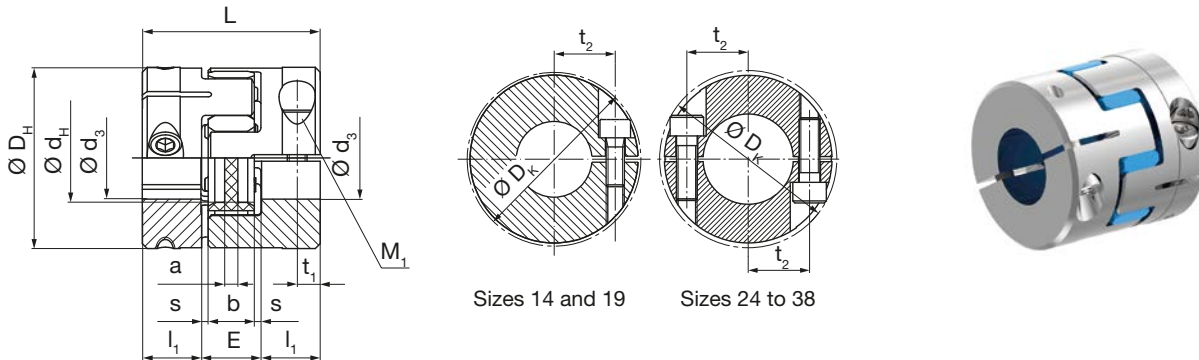
ROBA®-ES with clamping hubs Compact
Sizes 14 to 38
Single-jointed coupling / Type 940._ 55._

Technical Data and Main Dimensions			Size				
			14	19	24	28	38
Minimum hub bore ^{1) 2)}	$d_3^{F7_{min}}$	[mm]	5	8	10	14	15
Maximum hub bore ^{1) 2)}	$d_3^{F7_{max}}$	[mm]	12	20	32	35	45
Maximum speed ^{3) 4)}	n_{max}	[rpm]	12600	9300	7000	5600	4700
Tightening torque clamping screws	T_A	[Nm]	3	10	10	25	48

Mass moments of inertia J [10⁻³ kgm²] ^{5) 6)}

	Size	14	19	24	28	38
Elastomeric element		0.0005	0.0012	0.0067	0.0154	0.042
Clamping hub		0.0025	0.0139	0.0493	0.1174	0.328
Single-jointed coupling short		0.0055	0.029	0.1053	0.2502	0.698
Sleeve with $H_s = 1000$ mm		0.075	0.27	0.74	1.33	2.42
Sleeve with 1000 mm tube		0.071	0.236	0.676	1.202	1.917

Weights [kg] ^{5) 6)}

	Size	14	19	24	28	38
Elastomeric element		0.0048	0.007	0.019	0.037	0.054
Clamping hub		0.0192	0.055	0.098	0.173	0.311
Single-jointed coupling short		0.0432	0.117	0.215	0.383	0.676
Sleeve with $H_s = 1000$ mm		0.595	1.036	1.323	1.631	2.101
Sleeve with 1000 mm tube		0.574	0.86	1.22	1.477	1.705

Dimensions	Size				
	14	19	24	28	38
a	2	3	4	5	6
b	10	12	14	15	18
D_H	30	40	55	65	80
D_K	31	46	58	69.5	86
d_H	10.5	18	27	30	38.5
E	13	16	18	20	24
L	32	50	54	62	76
L_2	53	76	88	100	120
L_3	dependent on H_s				
l_1	9.5	17	18	21	26
l_2	34	42	52	58	68
$H_{s_{min}}$	68	87	101	115	143
$H_{s_{max}}$	2000	2000	2000	2000	2000
M_1	M4	M6	2xM6	2xM8	2xM10
s	1.5	2	2	2.5	3
t_1	5	8	7	9	10
t_2	9.6	14	20	23.8	30.5

We reserve the right to make dimensional and constructional alterations.

Stock program	Size					
	Bore	14	19	24	28	38
Ø6						
Ø7						
Ø8	x					
Ø9	x					
Ø10	x	x				
Ø11	x	x				
Ø12	x	x				
Ø14		x				
Ø15		x	x			
Ø16		x	x			
Ø17						
Ø18			x			
Ø19			x	x		
Ø20			x	x		
Ø22			x	x		
Ø24			x	x		
Ø25			x	x	x	
Ø28			x	x		
Ø30				x		
Ø32				x	x	
Ø35					x	
Ø38						x
Ø40						x

ROBA[®]-ES with clamping hubs Compact

Sizes 14 to 65

Double-jointed coupling short / Type 942._55._

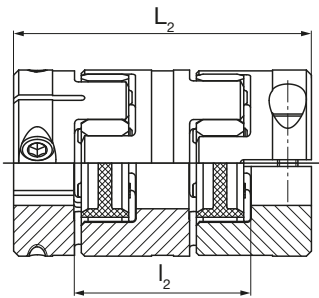

Double-jointed coupling with sleeve / Type 943._55._

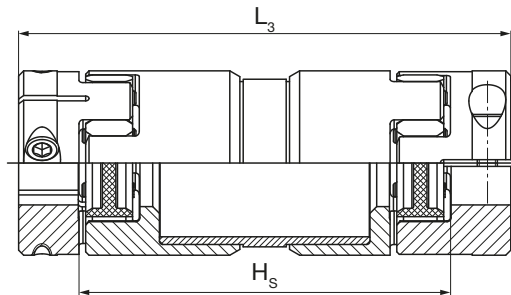

Order Number

		0 Single-jointed coupling 2 Double-jointed coupling short 3 Double-jointed coupling with sleeve				Sleeve length H _s [mm]			
___ / 9 4 ___ . ___ 5 5 . ___ / ___ / ___ / ___ / ___									
△			△			△	△	△	△
Size 14 to 65 ⁷⁾	Elastomeric element hardness	98 Sh A (red) 92 Sh A (yellow) 80 Sh A (blue) 64 Sh D (green)	0 1 5 6	Aluminium design up to Size 38	A	Bore ø d ₃ ^{F7} (see Table)	Bore ø d ₃ ^{F7} (see Table)	Operating speed n _s [rpm] for sleeve	

Example: 38 / 940.055.A / Ød₃ 30 / Ød₃ 30

- 1) Recommended hub / shaft tolerance: F7 / k6
- 2) Transmittable torques dependent on bore, see page 28.
- 3) Also applicable for double-jointed design
- 4) Not valid for designs with sleeve (see diagram: "Permitted speeds for sleeve" on page 26)
- 5) Mass moments of inertia and weights are valid for one elastomeric element
- 6) Mass moments of inertia and weights are valid for maximum bore
- 7) Further Sizes available on request

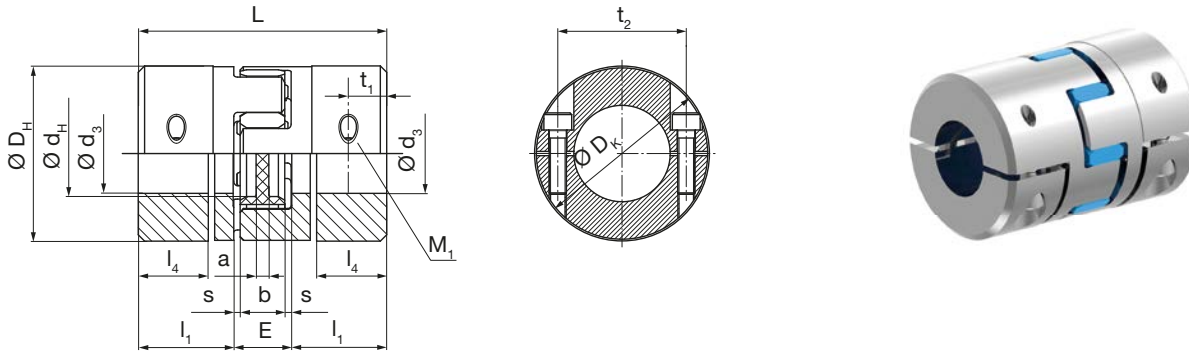
ROBA®-ES with split clamping hubs
Sizes 14 to 65
Single-jointed coupling / Type 940._ 33._

Technical Data and Main Dimensions			Size								
			14	19	24	28	38	42	48	55	65
Minimum hub bore ^{1) 2)}	$d_3^{H7}_{min}$	[mm]	8	8	10	14	18	22	22	40	45
Maximum hub bore ^{1) 2)}	$d_3^{H7}_{max}$	[mm]	15	20	28	35	45	50	55	70	80
Maximum speed ^{3) 4)}	n_{max}	[rpm]	12600	9300	7000	5600	4700	4000	3700	3300	3000
Tightening torque clamping screws	T_A	[Nm]	1.4	10	10	25	25	48	84	84	84

Mass moments of inertia J [10⁻³ kgm²] ^{5) 6)}

	Size	14	19	24	28	38	42	48	55	65
Elastomeric element		0.0005	0.0012	0.0067	0.0154	0.042	0.09	0.143	0.248	0.474
Split clamping hub		0.0041	0.0193	0.077	0.176	0.5003	3.045	5.051	9.536	17.693
Single-jointed coupling short		0.0087	0.0398	0.1607	0.3674	1.0426	6.18	10.245	19.32	35.86
Sleeve with $H_s = 1000$ mm		0.075	0.27	0.74	1.33	2.42	14.33	29.7	48.94	71.43
Sleeve with 1000 mm tube		0.071	0.236	0.676	1.202	1.917	10.676	24.89	41.167	54.082

Weights [kg] ^{5) 6)}

	Size	14	19	24	28	38	42	48	55	65
Elastomeric element		0.0048	0.007	0.019	0.037	0.054	0.081	0.104	0.149	0.216
Split clamping hub		0.0294	0.076	0.16	0.258	0.475	2.104	2.867	3.95	5.737
Single-jointed coupling short		0.0636	0.159	0.339	0.553	1.004	4.289	5.838	8.049	11.69
Sleeve with $H_s = 1000$ mm		0.595	1.036	1.323	1.631	2.101	9.429	15.764	18.009	21.351
Sleeve with 1000 mm tube		0.574	0.86	1.22	1.477	1.705	7.383	13.561	15.193	16.622

Dimensions	Size									
	14	19	24	28	38	42	48	55	65	
a	2	3	4	5	6	6	5	9	8	
b	10	12	14	15	18	20	21	22	26	
D_H	30	40	55	65	80	95	105	120	135	
D_K	32.2	47	58	71	83	99	106.5	122	136	
d_H	10.5	18	27	30	38.5	46	51	60	68	
E	13	16	18	20	24	26	28	30	35	
L	50	66	78	90	114	126	140	160	185	
L₂	71	92	112	128	158	174	192	218	252	
L₃	dependent on L _R									
L_{R min}	76.5	103	117	133	169	184	204	223	267	
L_{R max}	2008.5	2016	2016	2018	2026	2022	2026	3023	3037	
l₁	18.5	25	30	35	45	50	56	65	75	
l₂	34	42	52	58	68	74	80	88	102	
H_{S min}	68	87	101	115	143	162	178	200	230	
H_{S max}	2000	2000	2000	2000	2000	2000	2000	3000	3000	
l₄	14.25	17	22	26	32	39	43	53.5	56.5	
M₁	M3	M6	M6	M8	M8	M10	M12	M12	M12	
s	1.5	2	2	2.5	3	3	3.5	4	4.5	
t₁	7	8.5	12	13.5	16	20	22	26	27.5	
t₂	22	28	42	48	60	72	72	90	104	

ROBA[®]-ES with split clamping hubs

Sizes 14 to 65

Double-jointed coupling short / Type 942._33._

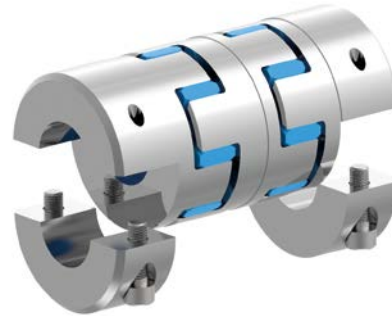
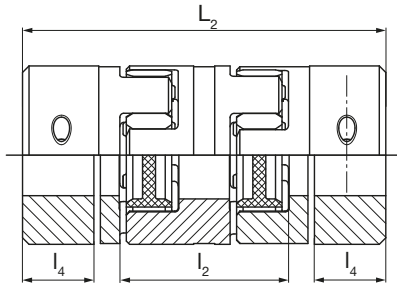

Double-jointed coupling with sleeve / Type 943._33._

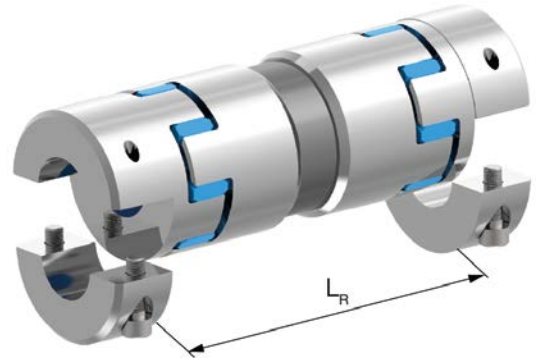
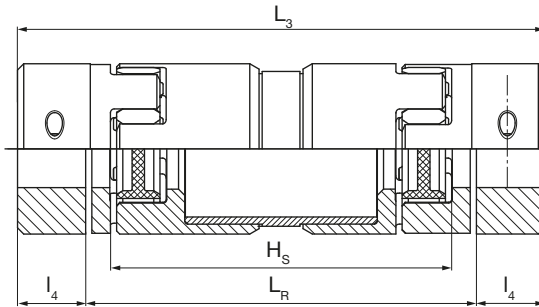

Order Number

- 0 Single-jointed coupling
- 2 Double-jointed coupling short
- 3 Double-jointed coupling with sleeve

Shaft distance
 L_R [mm]

___ / 9		4	___ . ___	3	3	___ / ___ / ___ / ___ / ___		
△			△			△	△	△
Size	Elastomeric element hardness	98 Sh A (red)	0	Aluminium design up to Size 38	A	Bore $\varnothing d_3^{H7}$ (see Table)	Bore $\varnothing d_3^{H7}$ (see Table)	Operating speed n_s [rpm] for sleeve
14		92 Sh A (yellow)	1	Steel design from Size 42	F			
to		80 Sh A (blue)	5					
65⁷⁾		64 Sh D (green)	6					

Example: 42 / 940.033.F / $\varnothing d_3$ 30 / $\varnothing d_3$ 30

- 1) Recommended hub / shaft tolerance: H7 / g6
- 2) Transmittable torques dependent on bore, see page 29.
- 3) Also applicable for double-jointed design
- 4) Not valid for designs with sleeve (see diagram: "Permitted speeds for sleeve" on page 26)
- 5) Mass moments of inertia and weights are valid for one elastomeric element
- 6) Mass moments of inertia and weights are valid for maximum bore
- 7) Further Sizes available on request

ROBA®-ES with aluminium shrink disk hubs

Sizes 14 to 38

Single-jointed coupling / Type 940._ 11.A

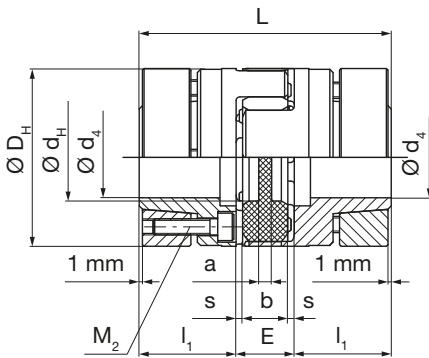

Technical Data and Main Dimensions			Size				
			14	19	24	28	38
Minimum hub bore ^{1) 2)}	$d_4^{H7}_{min}$	[mm]	6	10	15	19	20
Maximum hub bore ^{1) 2)}	$d_4^{H7}_{max}$	[mm]	14	20	28	38	45
Maximum speed ³⁾	n_{max}	[rpm]	28000	21000	15500	13200	10500
Tightening torque clamping screws	T_A	[Nm]	1.3	3	6	6	10

Mass moments of inertia J [10⁻³ kgm²] ^{4) 5)}

	Size	14	19	24	28	38
Elastomeric element		0.0005	0.0012	0.0067	0.0154	0.042
Shrink disk hub		0.0065	0.0313	0.134	0.304	0.929
Single-jointed coupling short		0.0135	0.0638	0.2747	0.6234	1.9

Weights [kg] ^{4) 5)}

	Size	14	19	24	28	38
Elastomeric element		0.0048	0.007	0.019	0.037	0.054
Shrink disk hub		0.046	0.12	0.271	0.412	0.852
Single-jointed coupling short		0.0968	0.247	0.561	0.861	1.758

Dimensions	Size				
	14	19	24	28	38
a	2	3	4	5	6
b	10	12	14	15	18
D _H	30	40	55	65	80
d _H	10.5	18	27	30	38.5
E	13	16	18	20	24
L	50	66	78	90	114
L ₂	71	92	112	128	158
l ₁	18.5	25	30	35	45
l ₂	34	42	52	58	68
M ₂	4xM3	6xM4	4xM5	8xM5	8xM6
s	1.5	2	2	2.5	3

We reserve the right to make dimensional and constructional alterations.

Stock program	Size				
	14	19	24	28	38
Bore					
Ø10	x				
Ø11					
Ø12	x	x			
Ø14	x	x			
Ø15		x	x		
Ø16		x	x		
Ø18			x		
Ø19		x	x		
Ø20		x	x	x	
Ø22			x	x	
Ø24			x	x	x
Ø25			x	x	x
Ø28			x	x	x
Ø30				x	x
Ø32				x	x
Ø35				x	x
Ø38					x
Ø40					

ROBA[®]-ES with aluminium shrink disk hubs

Sizes 14 to 38

Double-jointed coupling short / Type 942._ 11.A

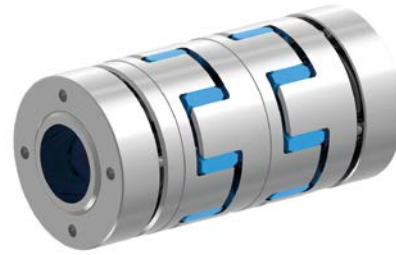
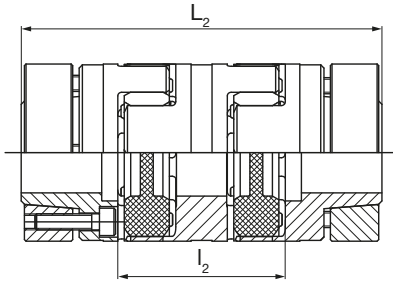

Order Number

- 0 Single-jointed coupling
- 2 Double-jointed coupling short



_	/	9	4	_	.	_	1	1	.	_	/	_	/	_
▲						▲				▲		▲		▲
Size	Elastomeric element hardness	98 Sh A (red)	0	Aluminium design	A	Bore σ	Bore σ							
14		92 Sh A (yellow)	1			d_4^{H7}	d_4^{H7}							
to		80 Sh A (blue)	5			(see Table)								
38⁶⁾		64 Sh D (green)	6											

Example: 38 / 940.011.A / σd_4 30 / σd_4 30

- 1) Recommended hub / shaft tolerance: H7 / k6
- 2) Transmittable torques dependent on bore, see page 27.
- 3) Also applicable for double-jointed design
- 4) Mass moments of inertia and weights are valid for one elastomeric element
- 5) Mass moments of inertia and weights are valid for maximum bore
- 6) Further Sizes available on request

ROBA®-ES with steel shrink disk hubs

Sizes 14-32 to 65

Single-jointed coupling / Type 940._11._

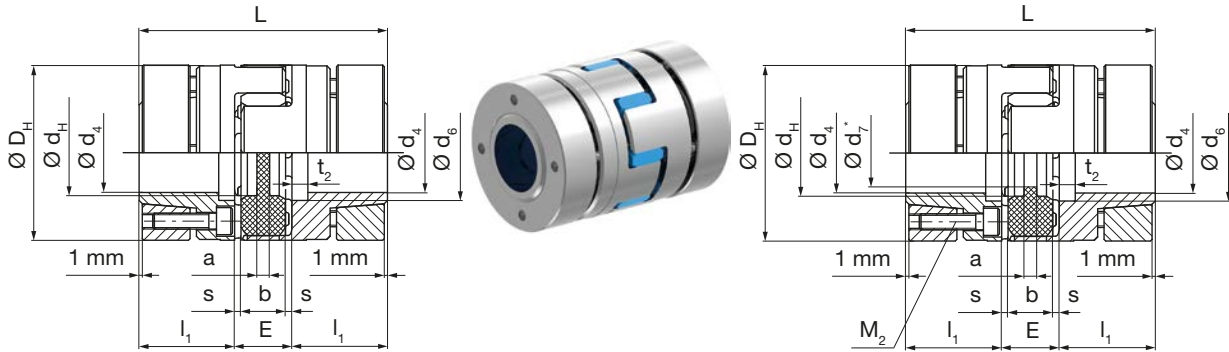

Type 940._11.P – Sizes 14 to 38
Type 940._11.F – Sizes 42 to 65

Type 940.011.P
Sizes 14-32 to 28 acc. DIN 69002

Technical Data and Main Dimensions			Size											
			14-32	19-37.5	19	24-50	24	28	38	42	48	55	65	
Minimum hub bore ¹⁾²⁾	$d_{4 \min}$	[mm]	6	10	10	15	15	19	20	28	35	40	45	
Maximum hub bore ¹⁾²⁾	$d_{4 \max}$	[mm]	14	16	20	24	28	38	45	50	60	70	75	
DIN-bore ³⁾	d_4	[mm]	14	16	19	24	25	35	-	-	-	-	-	
Maximum speed	single-jointed	n_{\max}	[rpm]	28000	21000	21000	15500	15500	13200	10500	9000	8000	6300	5600
	Double-jointed short	n_{\max}	[rpm]	-	-	-	-	-	-	-	9000	8000	6300	5600
Tightening torque clamping screws	T_A	[Nm]	1.3	3.0	3.0	6.0	6.0	6.0	10	25	30	52	90	

Mass moments of inertia J [10^{-3} kgm^2] ^{4) 5)}

	Size	14-32	19-37.5	19	24-50	24	28	38	42	48	55	65
Elastomeric element		0.0005	0.0012	0.0012	0.0067	0.0067	0.0154	0.042	0.09	0.143	0.248	0.474
Shrink disk hub		0.0128	0.0368	0.0471	0.136	0.202	0.433	1.332	2.948	4.809	9.099	17.287
Single-jointed coupling short		0.0261	0.0748	0.0954	0.2787	0.4107	0.8814	2.706	5.986	9.761	18.446	35.048

Weights [kg] ^{4) 5)}

	Size	14-32	19-37.5	19	24-50	24	28	38	42	48	55	65
Elastomeric element		0.0048	0.007	0.007	0.019	0.019	0.037	0.054	0.081	0.104	0.149	0.216
Shrink disk hub		0.086	0.174	0.185	0.348	0.418	0.606	1.256	2.022	2.62	3.754	5.766
Single-jointed coupling short		0.1768	0.355	0.377	0.715	0.855	1.249	2.566	4.125	5.344	7.657	11.748

Dimensions	Size										
	14-32	19-37.5	19	24-50	24	28	38	42	48	55	65
a	2	4	4	4	4	5	5	5	5	9	8
b	10	12	12	14	14	15	18	20	21	22	26
D_H	32	37.5	40	50	55	65	80	95	105	120	135
d_H	10.5	18	18	27	27	30	38	46	51	60	68
d_6	17	19	22	29	30	40	46	55	60	72	77
d_7 ³⁾	8.5	9.5	9.5	12.5	12.5	14.5	-	-	-	-	-
E	13	16	16	18	18	20	24	26	28	30	35
L	50	66	66	78	78	90	114	126	140	160	185
L_2								174	192	218	252
l_1	18.5	25	25	30	30	35	45	50	56	65	75
l_2								74	80	88	102
M_2	4 x M3	6 x M4	6 x M4	4 x M5	4 x M5	8 x M5	8 x M6	4 x M8	4 x M8	4 x M10	4 x M12
s	1.5	2.0	2.0	2.0	2.0	2.5	3.0	3.0	3.5	4.0	4.5
t_2	3	4	4	5	5	5	5	5	6	7	7

We reserve the right to make dimensional and constructional alterations.

ROBA[®]-ES with steel shrink disk hubs

Sizes 14-32 to 65

Double-jointed coupling short / Type 942._ 11._

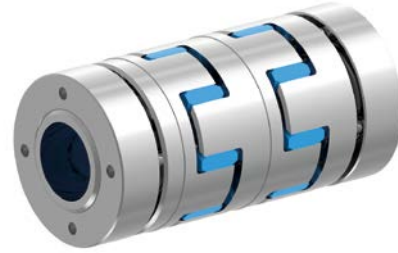
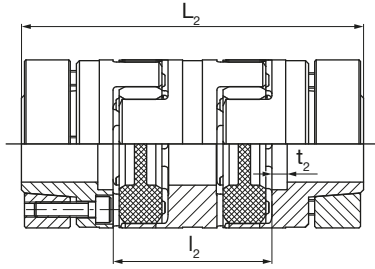

Order Number

		0 Single-jointed coupling 2 Double-jointed coupling short ⁶⁾				Bore ø d_4^{H6} up to Size 38 d_4^{H7} from Size 42 (see Table)	
		▼				▼	
_ / 9 4		_ . _		1 1 . _ / _ / _ / _			
▲		▲		▲		▲	
Size 14-32 to 65 ⁷⁾	Elastomeric element hardness 98 Sh A (red) 92 Sh A (yellow) 80 Sh A (blue) 64 Sh D (green)	0 1 5 6	Steel design up to Size 38 Steel design from Size 42	P F	Bore ø d_4^{H6} up to Size 38 d_4^{H7} from Size 42 (see Table)	Design - DIN - No values for standard	

Example: 42 / 940.011.F / Ød₄ 30 / Ød₄ 30

- 1) Recommended hub / shaft tolerance: H6 / k6, from Size 42: H7 / k6
- 2) Transmittable torques dependent on bore, see page 27.
- 3) Elastomeric elements with DIN bores only available with 98 Sh A (red), Type 940.011.P
- 4) Mass moments of inertia and weights are valid for one elastomeric element
- 5) Mass moments of inertia and weights are valid for maximum bore
- 6) Double-joint designs are only available from Size 42.

7) Further Sizes available on request

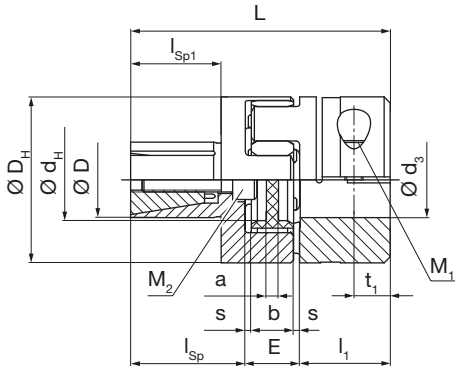
ROBA®-ES with expansion hub and clamping hub
Sizes 14 to 28
Single-jointed coupling / Type 940._ 40._

Technical Data and Main Dimensions			Size			
			14	19	24	28
Minimum hub bore ^{1) 2)}	$d_3^{H7}_{min}$	[mm]	6	6	8	10
Maximum hub bore ^{1) 2)}	$d_3^{H7}_{max}$	[mm]	15	20	28	35
Diameter expansion hub	D_{h7}	[mm]	12	20	25	35
Maximum speed	n_{max}	[rpm]	12600	9300	7000	5600
Tightening torque M_2	T_A	[Nm]	5.8	10.1	24	48

Mass moments of inertia J [10^{-3} kgm²] ^{3) 4)}

	Size	14	19	24	28
Elastomeric element		0.0005	0.0012	0.0067	0.0154
Clamping hub		0.0028	0.0193	0.076	0.168
Expansion hub		0.0019	0.0097	0.043	0.081
Single-jointed coupling short		0.0052	0.0302	0.1257	0.2644

Weights [kg] ^{3) 4)}

	Size	14	19	24	28
Elastomeric element		0.0048	0.007	0.019	0.037
Clamping hub		0.02	0.076	0.159	0.245
Expansion hub		0.023	0.071	0.188	0.286
Single-jointed coupling short		0.0478	0.154	0.366	0.568

Dimensions	Size			
	14	19	24	28
a	2	3	4	5
b	10	12	14	15
D_H	30	40	55	65
D_K	32.2	47	56.4	72.6
d_H	10.5	18	27	30
E	13	16	18	20
L	42.5	69	86	109
l_1	11	25	30	35
l_{Sp}	18.5	28	38	54
l_{Sp1}	12.5	20	30	36
M_1	M3	M6	M6	M8
M_2	M5	M6	M8	M10
s	1.5	2	2	2.5
t_1	5.5	12	12	13.5

Order Number

0 Single-jointed coupling

__	/	9	4	__	.	__	4	0	.	__	/	__	/	__	
△				△						△	△	△			
Size 14 to 28 ⁵⁾	Elastomeric element hard- ness	98 Sh A (red)	0	Aluminium design	A	$\varnothing D_{h7}$ (see Table)	Bore \varnothing d_3^{H7} (see Table)								
		92 Sh A (yellow)	1												
		80 Sh A (blue)	5												
		64 Sh D (green)	6												

Example: 28 / 940.040.A / $\varnothing D$ 35 / $\varnothing d_3$ 30

- 1) Recommended fit connection for expansion hub: H7 / h7
- 2) Transmittable torques dependent on bore, see page 29.
- 3) Mass moments of inertia and weights are valid for one elastomeric element
- 4) Mass moments of inertia and weights are valid for maximum bore
- 5) Further Sizes available on request

ROBA®-ES Coupling Dimensioning

1. Approximate calculation of the coupling torque:

1.1. T_N from the nominal power

$$T_N = \frac{9550 \times P_{AN/LN}}{n}$$

1.2. Dynamic torques T_S and T_W (5.1 and 5.2):

Input-side excitation:

Output-side excitation:

Peak torque: $T_S = T_{AS} \times \frac{J_L}{J_A + J_L} \times S_A$

Peak torque: $T_S = T_{LS} \times \frac{J_A}{J_A + J_L} \times S_L$

Alternating torque: $T_W = T_{AW} \times \frac{J_L}{J_A + J_L} \times V_R$

Alternating torque: $T_W = T_{LW} \times \frac{J_A}{J_A + J_L} \times V_R$

2. Comparison of torques occurring in the coupling with the permitted torques

The coupling must be dimensioned so that the loads occurring do not exceed the permitted values in any operating state.

2.1. Load due to nominal torque

$$T_{KN} \geq T_N \times S_\delta$$

2.2. Load due to torque impacts (5.3)

$$T_{Kmax} \geq T_S \times S_Z \times S_\delta + T_N \times S_\delta$$

2.3. Load due to resonance passing through (5.4)

$$T_{Kmax} \geq T_S \times S_Z \times S_\delta \times V_R + T_N \times S_\delta$$

2.4. Load due to constantly alternating torque – cycle operation (5.5 and 5.6)

Permitted alternating torque on coupling:

$$T_{KW} = 0.25 \times T_{KN} \text{ (for aluminium hubs)}$$

$$T_{KW} = 0.35 \times T_{KN} \text{ (for steel hubs)}$$

$$T_{KW} \geq T_W \times S_\delta \times S_f$$

3. Inspection of permitted misalignments

$$\Delta K_a \geq \Delta W_a \times S_\delta$$

$$\Delta K_r \geq \Delta W_r \times S_\delta \times S_n$$

$$\Delta K_w \geq \Delta W_w \times S_\delta \times S_n$$

If more than one kind of misalignment occurs at the same time, please observe Fig. 2 (page 30).

4. Frictional locking inspection on hub connection

$T_R > T_{max}$: T_{max} is the maximum torque occurring in the coupling.

Values for T_R can be found on pages 27 to 29.

5. Explanations

5.1. The torque determination on the coupling is applicable if the shaft coupling in the system is the torsionally softest element, and therefore the system can be considered as a double-mass oscillator. If this is not the case, the calculation of the torque on the coupling requires a more detailed calculation procedure.

5.2. The impact factors S_A / S_L describe the impact progression. A rectangular progression of the peak torque is the heaviest impact ($S_A/S_L = 2.0$). A flat sinus progression of the peak torque is a light impact ($S_A/S_L = 1.2$).

5.3. T_S , the peak torque in the coupling, is the maximum torque on the coupling during the impact minus the system torque having an effect on the coupling during normal operation.

$$T_S = T_{max, impact} - T_N$$

5.4. If a drive is operated supercritically, meaning that the operating speed n lies above the resonance speed n_R , then resonance passing through causes particular loads.

If the resonance passes through quickly below the operating speed, only a few resonance peaks occur. The alternating torque in resonance can therefore be compared to the maximum torque on the coupling (see also 5.6).

5.5. S_f takes the frequency dependency of lifetime into account. The frequency dependency is first taken into account above 5 Hz.

5.6. On appreciable vibration excitation, the resonance must be moved out of the operating range by selecting a suitable torsional spring rigidity of the coupling.

ROBA®-ES Coupling Dimensioning

Service Factors for Coupling Dimensioning

V_R = Resonance factor

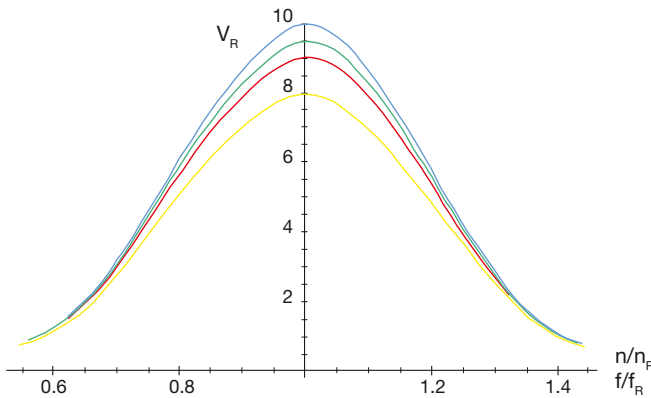

n_R = Resonance speed

$$n_R = \frac{30}{\pi} \sqrt{C_{T \text{ dyn.}} \frac{J_A + J_L}{J_A \times J_L}} \quad [\text{rpm}]$$

Blue: elast. element 80 Sh A
 Yellow: elast. element 92 Sh A
 Red: elast. element 98 Sh A
 Green: elast. element 64 Sh D

f_R = Resonance frequency

$$f_R = \frac{1}{2\pi} \sqrt{C_{T \text{ dyn.}} \frac{J_A + J_L}{J_A \times J_L}} \quad [\text{s}^{-1}]$$

S_n = Speed factor

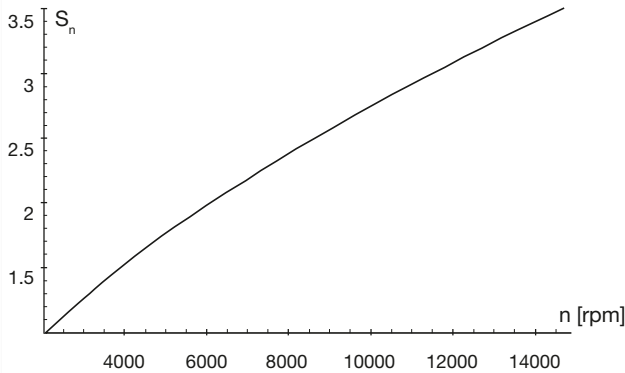

S_z = Start-up factor/impact frequency

S/h	0 – 100	101 – 200	201 – 400	401 – 800	801 – 1600
S_z	1	1.2	1.4	1.6	1.8

S_δ = Safety factor for temperature

T [°C]	-30 °C / +30 °C	+60 °C	+90 °C
S_δ	1	1.5	2

S_L or S_A = Impact factor

Impacts	S_A or S_L
Light impacts	1.2
Medium impacts	1.6
Heavy impacts	2.0

S_f = Frequency factor

f in Hz	≤ 5	> 5
S_f	1	$\sqrt{\frac{f}{5}}$

f shows the load alternation per second (Hz = s⁻¹)

Terms

$P_{AN/LN}$	[kW]	Input-side/load-side power
T_R	[Nm]	Transmittable torque (frictional locking, Tables pages 27 to 29)
$T_{AS/AW}$	[Nm]	Excitational torque input side
$T_{LS/LW}$	[Nm]	Excitational torque load side
T_N	[Nm]	System torque
T_W	[Nm]	System alternating torque
T_S	[Nm]	Peak torque
T_{max}	[Nm]	Maximum torque in the coupling
T_{KN}	[Nm]	Permitted nominal torque
T_{Kmax}	[Nm]	Permitted maximum torque
T_{KW}	[Nm]	Permitted permanent alternating torque
J_A	[kgm ²]	Mass moment of inertia, input side
J_L	[kgm ²]	Mass moment of inertia, load side
ΔK_a	[mm]	Permitted axial displacement
ΔK_r	[mm]	Permitted radial misalignment

ΔK_w	[°]	Permitted angular misalignment
ΔW_a	[mm]	Axial shaft misalignment
ΔW_r	[mm]	Radial shaft misalignment
ΔW_w	[°]	Angular shaft misalignment
c_T	[Nm/rad]	Torsional spring rigidity
n	[rpm]	Nominal speed
n_R	[rpm]	Resonance speed
S_{AVL}	[-]	Impact factor input side /load side
S_n	[-]	Speed factor
S_z	[-]	Start-up factor/impact frequency
S_δ	[-]	Temperature factor
S_f	[-]	Frequency factor
V_R	[-]	Resonance factor
f	[1/s]=[Hz]	Load factor
f_R	[Hz]	Resonance frequency

Technical Explanations

ROBA®-ES Elastomeric Elements

Elastomeric element hardness [Shore]	Colour	Permitted temperature range	
		Permanent temperature	Max. temporary temperature
80 Sh A	blue	-50 to +80 °C	-60 to +120 °C
92 Sh A	yellow	-40 to +90 °C	-50 to +120 °C
98 Sh A	red	-30 to +90 °C	-40 to +120 °C
64 Sh D	green	-30 to +100 °C	-40 to +140 °C

Torques

Size	Torques							
	Elastomeric element hardness 80 Sh A (blue)		Elastomeric element hardness 92 Sh A (yellow)		Elastomeric element hardness 98 Sh A (red)		Elastomeric element hardness 64 Sh D (green)	
	T _{KN} [Nm]	T _{K max} [Nm]	T _{KN} [Nm]	T _{K max} [Nm]	T _{KN} [Nm]	T _{K max} [Nm]	T _{KN} [Nm]	T _{K max} [Nm]
14	4	8	8	16	13	26	16	32
19	5	10	10	20	17	34	21	42
24	17	34	35	70	60	120	75	150
28	46	92	95	190	160	320	200	400
38	95	190	190	380	325	650	405	810
42	125	250	265	530	450	900	560	1120
48	150	300	310	620	525	1050	655	1310
55	200	400	410	820	685	1370	825	1650
65	450	900	900	1800	1040	2080	1250	2500

Please Observe: To determine the coupling torque, refer to „ROBA®-ES Coupling Dimensioning,, starting on page 22!

Spring rigidity ¹⁾

Size	Torsional spring rigidity								Radial spring rigidity				
	static C _{T stat.}				dynamic C _{T dyn.}				relative C _{T H rel.}	static C _r			
	80 Sh A	92 Sh A	98 Sh A	64 Sh D	80 Sh A	92 Sh A	98 Sh A	64 Sh D		Sleeve	80 Sh A	92 Sh A	98 Sh A
	[Nm/rad.]								[10 ⁶ Nm mm/rad.]		[N/mm]		
14	50	80	120	230	120	240	300	730	0.65	180	300	470	960
19	350	820	900	1400	1050	1800	2200	4200	2.18	700	1200	2100	2700
24	820	2300	3700	4500	1300	4800	7600	10800	6.26	800	1900	2800	4200
28	1300	3800	4200	7000	2200	6800	10100	17200	11.15	950	2100	3500	4900
38	2000	5600	7400	9000	3400	11900	19900	30500	18.11	1300	2900	4800	5600
42	3500	9800	13800	15000	5950	20500	31100	64900	109.66	3400	4100	5400	6900
48	4300	12000	15100	28500	7300	22800	44900	102800	254.50	3750	4500	6200	8200
55	5100	14200	20500	56300	8300	25800	48200	117400	421.75	4730	5680	8200	22500
65	6800	19100	32800	90200	11500	36200	67400	164000	555.18	6360	7640	13120	36000
Only for type 940...11.P													
14-32	50	80	120	230	120	240	300	730	-	180	300	470	960
19-37.5	280	660	720	1120	840	1440	1760	3360	-	560	960	1680	2160
24-50	600	1700	2700	3300	1000	3600	5700	8100	-	600	1500	2100	3200

1) The C_r-value of a double-jointed coupling can be roughly calculated as follows:

$$C_{T ges.} = \frac{1}{\frac{2}{C_T} + \frac{H_s [mm] - 2 E [mm]}{C_{T H rel.}}}$$

Technical Explanations

Permitted Misalignment Values

Size	Shaft misalignments Basic Type								
	Axial	Radial				Angular			
	ΔK_a 80/92 Sh A 98/64 Sh D [mm]	ΔK_r 80 Sh A [mm]	ΔK_r 92 Sh A [mm]	ΔK_r 98 Sh A [mm]	ΔK_r 64 Sh D [mm]	ΔK_w 80 Sh A [°]	ΔK_w 92 Sh A [°]	ΔK_w 98 Sh A [°]	ΔK_w 64 Sh D [°]
Misalignment values Basic Type									
14	1.0	0.21	0.15	0.09	0.06	1.1	1.0	0.9	0.8
19	1.2	0.15	0.1	0.06	0.04	1.1	1.0	0.9	0.8
24	1.4	0.18	0.14	0.1	0.07	1.1	1.0	0.9	0.8
28	1.5	0.2	0.15	0.11	0.08	1.3	1.0	0.9	0.8
38	1.8	0.22	0.17	0.12	0.09	1.3	1.0	0.9	0.8
42	2.0	0.24	0.19	0.14	0.1	1.3	1.0	0.9	0.8
48	2.1	0.26	0.21	0.16	0.11	1.3	1.0	0.9	0.8
55	2.2	0.28	0.24	0.17	0.12	1.3	1.0	0.9	0.8
65	2.6	0.3	0.25	0.18	0.13	1.3	1.0	0.9	0.8
Only available on P-design									
14-32	1.0	0.21	0.15	0.09	0.06	1.1	1.0	0.9	0.8
19-37.5	1.2	0.15	0.1	0.06	0.04	1.1	1.0	0.9	0.8
24-50	1.4	0.18	0.14	0.1	0.07	1.1	1.0	0.9	0.8
Misalignment values with connection piece									
						per side			
14	2.0	0.42	0.30	0.18	0.12	1.1	1.0	0.9	0.8
19	2.4	0.3	0.20	0.12	0.08	1.1	1.0	0.9	0.8
24	2.8	0.36	0.28	0.20	0.14	1.1	1.0	0.9	0.8
28	3.0	0.4	0.30	0.22	0.16	1.3	1.0	0.9	0.8
38	3.6	0.44	0.34	0.24	0.18	1.3	1.0	0.9	0.8
42	4.0	0.48	0.38	0.28	0.20	1.3	1.0	0.9	0.8
48	4.2	0.52	0.42	0.32	0.22	1.3	1.0	0.9	0.8
55	4.4	0.56	0.48	0.34	0.24	1.3	1.0	0.9	0.8
65	5.2	0.6	0.50	0.36	0.26	1.3	1.0	0.9	0.8
Misalignment values with sleeve									
		$(L_3 - 2 \times l_1 - E) \times A$ (Calculation factor)				per side			
14	2.0	A = 0.0097				1.1	1.0	0.9	0.8
19	2.4					1.1	1.0	0.9	0.8
24	2.8					1.1	1.0	0.9	0.8
28	3.0	A = 0.0113	A = 0.0087	A = 0.0079	A = 0.0070	1.3	1.0	0.9	0.8
38	3.6					1.3	1.0	0.9	0.8
42	4.0					1.3	1.0	0.9	0.8
48	4.2					1.3	1.0	0.9	0.8
55	4.4					1.3	1.0	0.9	0.8
65	5.2	1.3	1.0	0.9	0.8				

Technical Explanations

Permitted Speeds (critical bending speed) for Sleeve

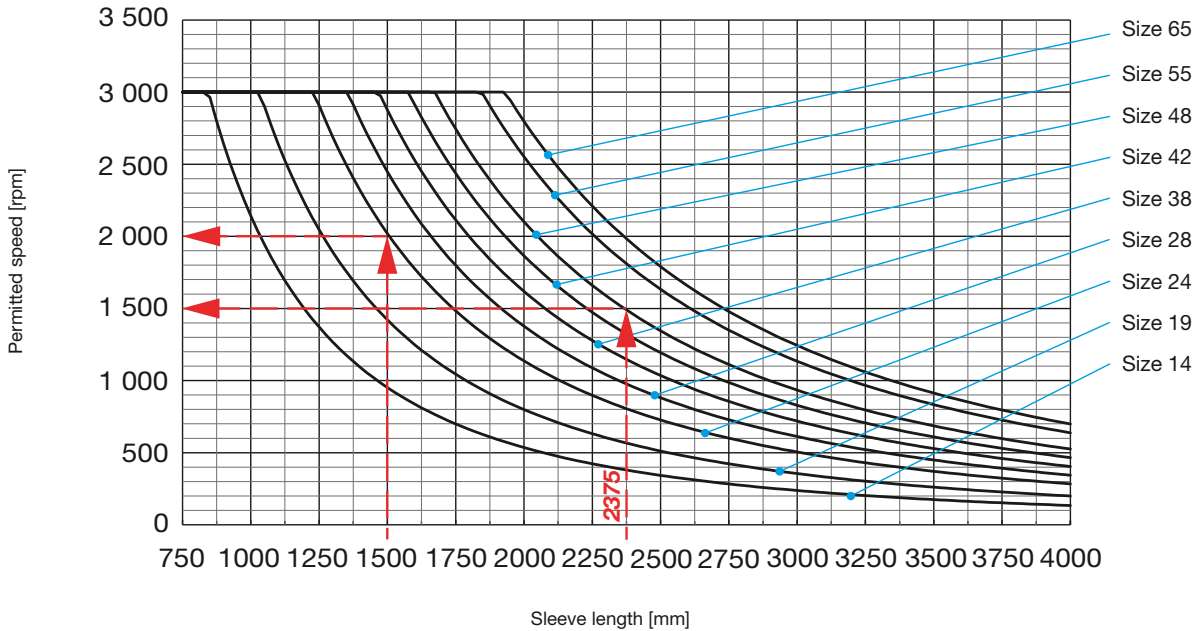

Examples

- ROBA[®]-ES, Size 48:

Sleeve length: $H_s = 2375 \text{ mm}$
=> permitted speed: **1500 rpm**

- ROBA[®]-ES, Size 24:

Sleeve length: $H_s = 1500 \text{ mm}$
=> permitted speed: **2000 rpm**

Using the coupling at high speeds

- Please keep to the maximum speeds defined in the catalogue. Higher speeds are only permitted after contacting the manufacturers.
- Please operate designs with sleeve at subcritical levels.
- Both hub variants clamping hub and split clamping hub may only be used within a limited speed range. At very high speeds, shrink disk hubs and key hubs (press fit) should be used.
- We recommend balancing the coupling in individual parts or complete.
- Shaft misalignments should be kept as low as possible to increase the smooth running of a system.
- When using double cardanic shafts, axial animation of the middle coupling part is possible due to operating speed and misalignment. In order to avoid this animation, please minimise the shaft misalignment.

Technical Explanations

Transmittable Torques

Shrink disk hubs made of aluminium Type 940._11.A			Bore	Size				
				14	19	24	28	38
Frictionally-locking transmittable torques Shrink disk hubs made of aluminium	T_R	[Nm]	Ø6	7	-	-	-	-
			Ø7	9	-	-	-	-
			Ø8	11	-	-	-	-
			Ø9	13	-	-	-	-
			Ø10	15	33	-	-	-
			Ø11	17	38	-	-	-
			Ø14	24	55	-	-	-
			Ø15	-	61	56	-	-
			Ø16	-	67	62	-	-
			Ø17	-	73	68	-	-
			Ø18	-	78	74	-	-
			Ø19	-	84	81	141	-
			Ø20	-	88	87	153	197
			Ø22	-	-	100	177	228
			Ø24	-	-	120	203	261
			Ø25	-	-	125	216	279
			Ø28	-	-	135	256	332
			Ø30	-	-	-	282	368
			Ø32	-	-	-	308	405
			Ø35	-	-	-	343	460
Ø38	-	-	-	373	513			
Ø40	-	-	-	-	547			
Ø42	-	-	-	-	577			
Ø45	-	-	-	-	617			

Suitable for H7 / k6
With larger fit clearance, the transmittable torque is reduced.

Shrink disk hubs made of steel Type 940._11.P			Bore	Size					
				14-32	19-37.5	19	24-50	24	28
Frictionally-locking transmittable torques Shrink disk hubs made of steel	T_R	[Nm]	Ø6	7	-	-	-	-	-
			Ø7	9	-	-	-	-	-
			Ø8	11	-	-	-	-	-
			Ø9	13	-	-	-	-	-
			Ø10	15	26	33	-	-	-
			Ø11	17	30	38	-	-	-
			Ø14	25	45	55	-	-	-
			Ø15	-	50	61	45	56	-
			Ø16	-	60	67	50	62	-
			Ø17	-	-	73	54	68	-
			Ø18	-	-	78	60	74	-
			Ø19	-	-	84	65	81	141
			Ø20	-	-	88	70	87	153
			Ø22	-	-	-	85	100	177
			Ø24	-	-	-	112	120	203
			Ø25	-	-	-	-	125	216
			Ø28	-	-	-	-	135	256
			Ø30	-	-	-	-	-	282
			Ø32	-	-	-	-	-	308
			Ø35	-	-	-	-	-	343
Ø38	-	-	-	-	-	373			
Ø40	-	-	-	-	-	-			
Ø42	-	-	-	-	-	-			
Ø45	-	-	-	-	-	-			

Suitable for H6 / k6
With larger fit clearance, the transmittable torque is reduced.

Shrink disk hubs made of steel Type 940._11.F			Bore	Size			
				42	48	55	65
Frictionally-locking transmittable torques Shrink disk hubs made of steel	T_R	[Nm]	Ø28	300	-	-	-
			Ø30	350	-	-	-
			Ø32	400	-	-	-
			Ø35	500	450	-	-
			Ø38	600	500	-	-
			Ø40	680	600	723	-
			Ø42	730	720	814	-
			Ø45	790	850	946	1402
			Ø48	850	1000	1085	1596
			Ø50	880	1180	1187	1731
			Ø52	-	1270	1284	1873
			Ø55	-	1353	1436	2095
			Ø58	-	1428	1585	2308
			Ø60	-	1471	1682	2420
			Ø62	-	-	1795	2570
			Ø65	-	-	1943	2750
			Ø68	-	-	2100	2989
Ø70	-	-	2207	3157			
Ø72	-	-	-	3306			
Ø75	-	-	-	3550			

Suitable for H7 / k6
With larger fit clearance, the transmittable torque is reduced.

Technical Explanations

Transmittable Torques

Clamping hubs Type 94_._00_.			Bore	Size									
				14	19	24	28	38	42	48	55	65	
Frictionally-locking transmittable torques Clamping hubs	T_R	[Nm]	Ø6	2.5	-	-	-	-	-	-	-	-	-
			Ø7	3.0	-	-	-	-	-	-	-	-	-
			Ø8	3.4	-	-	-	-	-	-	-	-	-
			Ø9	3.8	-	-	-	-	-	-	-	-	-
			Ø10	4.2	23	-	-	-	-	-	-	-	-
			Ø11	4.7	25	-	-	-	-	-	-	-	-
			Ø12	5.1	27	-	-	-	-	-	-	-	-
			Ø14	6.0	32	-	-	-	-	-	-	-	-
			Ø15	6.4	34	34	-	-	-	-	-	-	-
			Ø16	-	36	36	-	-	-	-	-	-	-
			Ø18	-	41	41	-	-	-	-	-	-	-
			Ø19	-	43	43	79	-	-	-	-	-	-
			Ø20	-	45	45	83	83	-	-	-	-	-
			Ø22	-	-	50	91	91	-	-	-	-	-
			Ø24	-	-	54	100	100	-	-	-	-	-
			Ø25	-	-	57	104	104	-	-	-	-	-
			Ø28	-	-	63	116	116	208	-	-	-	-
			Ø30	-	-	-	124	124	228	-	-	-	-
			Ø32	-	-	-	133	133	248	-	-	-	-
			Ø35	-	-	-	145	145	280	350	-	-	-
			Ø38	-	-	-	-	158	315	390	-	-	-
			Ø40	-	-	-	-	166	340	420	340	-	-
			Ø42	-	-	-	-	174	365	455	365	-	-
			Ø45	-	-	-	-	187	404	505	405	545	-
			Ø48	-	-	-	-	-	442	560	435	590	-
			Ø50	-	-	-	-	-	470	600	465	630	-
			Ø52	-	-	-	-	-	-	640	490	662	-
			Ø55	-	-	-	-	-	-	705	525	710	-
			Ø58	-	-	-	-	-	-	-	570	764	-
			Ø60	-	-	-	-	-	-	-	600	800	-
			Ø62	-	-	-	-	-	-	-	625	840	-
			Ø65	-	-	-	-	-	-	-	665	900	-
Ø68	-	-	-	-	-	-	-	700	954	-			
Ø70	-	-	-	-	-	-	-	740	990	-			
Ø72	-	-	-	-	-	-	-	-	1032	-			
Ø75	-	-	-	-	-	-	-	-	1095	-			
Ø78	-	-	-	-	-	-	-	-	1158	-			
Ø80	-	-	-	-	-	-	-	-	1200	-			

Suitable for F7 / k6
With larger fit clearance, the transmittable torque is reduced.

Clamping hubs Compact Type 94_._55_.			Bore	Size					
				14	19	24	28	38	
Frictionally-locking transmittable torques Clamping hubs Compact	T_R	[Nm]	Ø5	5	-	-	-	-	-
			Ø6	6	-	-	-	-	-
			Ø7	7	-	-	-	-	-
			Ø8	8	18	-	-	-	-
			Ø9	9	20	-	-	-	-
			Ø10	10	23	23	-	-	-
			Ø11	11	25	25	-	-	-
			Ø12	12	27	27	-	-	-
			Ø13	-	29	29	-	-	-
			Ø14	-	32	32	58	-	-
			Ø15	-	34	34	62	98	-
			Ø16	-	36	36	66	105	-
			Ø17	-	38	38	71	110	-
			Ø18	-	41	41	75	118	-
			Ø19	-	43	43	79	124	-
			Ø20	-	45	45	83	131	-
			Ø21	-	-	48	87	137	-
			Ø22	-	-	50	91	144	-
			Ø23	-	-	52	95	150	-
			Ø24	-	-	54	100	157	-
			Ø25	-	-	57	104	163	-
			Ø26	-	-	59	108	170	-
			Ø27	-	-	61	112	176	-
			Ø28	-	-	63	116	183	-
			Ø29	-	-	66	120	190	-
			Ø30	-	-	68	124	196	-
			Ø31	-	-	70	129	203	-
			Ø32	-	-	72	133	209	-
			Ø33	-	-	-	137	216	-
			Ø34	-	-	-	141	222	-
			Ø35	-	-	-	145	229	-
			Ø36	-	-	-	-	235	-
Ø37	-	-	-	-	242	-			
Ø38	-	-	-	-	248	-			
Ø39	-	-	-	-	255	-			
Ø40	-	-	-	-	261	-			
Ø41	-	-	-	-	268	-			
Ø42	-	-	-	-	274	-			
Ø43	-	-	-	-	281	-			
Ø44	-	-	-	-	288	-			
Ø45	-	-	-	-	294	-			

Suitable for F7 / k6
With larger fit clearance, the transmittable torque is reduced.

Technical Explanations

Transmittable Torques

Split Clamping Hubs			Size									
Type 94_._33_.			Bore	14	19	24	28	38	42	48	55	65
			Ø8	4	18							
			Ø9	4.5	20							
			Ø10	5	23	23						
			Ø11	5.5	25	25						
			Ø12	6	27	27						
			Ø13	6.5	29	29						
			Ø14	7	32	32	58					
			Ø15	7.5	34	34	62					
			Ø16		36	36	66					
			Ø17		38	38	71					
			Ø18		41	41	75	75				
			Ø19		43	43	79	79				
			Ø20		45	45	83	83				
			Ø21			48	87	87				
			Ø22			50	91	91	144	210		
			Ø23			52	95	95	150	220		
			Ø24			54	100	100	157	229		
			Ø25			57	104	104	163	239		
			Ø26			59	108	108	170	248		
			Ø27			61	112	112	176	258		
			Ø28			63	116	116	183	267		
			Ø29				120	120	190	277		
			Ø30				124	124	196	287		
			Ø31				129	129	203	296		
			Ø32				133	133	209	306		
			Ø33				137	137	216	315		
			Ø34				141	141	222	325		
			Ø35				145	145	229	334		
			Ø36					149	235	344		
			Ø37					153	242	353		
			Ø38					158	248	363		
			Ø39					162	255	372		
			Ø40					166	261	382	382	
			Ø41					170	268	392	392	
			Ø42					174	274	401	401	
			Ø43					178	281	411	411	
			Ø44					182	288	420	420	
			Ø45					187	294	430	430	430
			Ø46						301	439	439	439
			Ø47						307	449	449	449
			Ø48						314	458	458	458
			Ø49						320	468	468	468
			Ø50						327	478	478	478
			Ø51							487	487	487
			Ø52							497	497	497
			Ø53							506	506	506
			Ø54							516	516	516
			Ø55							525	525	525
			Ø56								535	535
			Ø57								544	544
			Ø58								554	554
			Ø59								563	563
			Ø60								573	573
			Ø61								583	583
			Ø62								592	592
			Ø63								602	602
			Ø64								611	611
			Ø65								621	621
			Ø66								630	630
			Ø67								640	640
			Ø68								649	649
			Ø69								659	659
			Ø70								669	669
			Ø71								678	678
			Ø72								688	688
			Ø73								697	697
			Ø74								707	707
			Ø75								716	716
			Ø76								726	726
			Ø77								735	735
			Ø78								745	745
			Ø79								755	755
			Ø80								764	764

Frictionally-locking transmittable torques

Split Clamping Hubs

Suitable for H7 / g6

With larger fit clearance, the transmittable torque is reduced.

T_R [Nm]

Expansion hubs			Size				
Type 94_._4_.			Bore	14	19	24	28
Frictionally-locking transmittable torques	T_R	[Nm]	Ø12	15.7			
			Ø20		36.6		
Suitable for H7 / h7	T_R	[Nm]	Ø25	84.4			
Expansion hubs made of steel			Ø35				188

Technical Explanations

ROBA[®]-ES stands for flexible (E), backlash-free (S) shaft coupling. The device consists of two coupling hubs and a flexible, star-shaped intermediate ring (Fig. 1).

ROBA[®]-ES couplings are conceived specially for backlash-free operation at comparatively high speeds.

ROBA[®]-ES couplings are mainly used in measurement and control engineering as well as in control and process engineering.

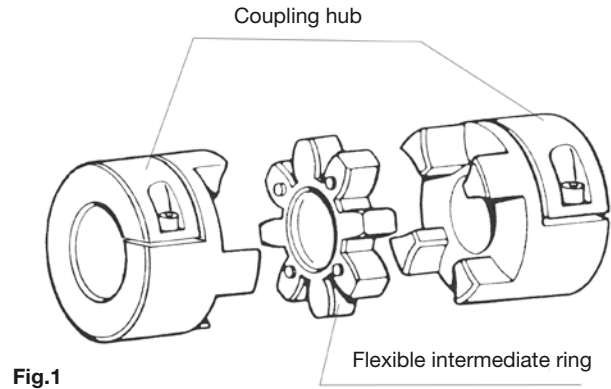

Fig.1

Shaft Misalignments

The ROBA[®]-ES coupling compensate for radial, axial and angular shaft misalignments (Fig. 3) without losing their backlash-free function. However, the permitted misalignments indicated on page 25 must not simultaneously reach their maximum value. If more than one kind of misalignment takes place simultaneously, they influence each other. This means that the permitted misalignment values are dependent on one another, see Fig. 2. The sum total of the actual misalignments – in percent of the maximum value – must not exceed 100 %.

The permitted misalignment values given on page 25 refer to coupling operation at nominal torque, an ambient temperature of +30 °C and an operating speed of 1500 rpm.

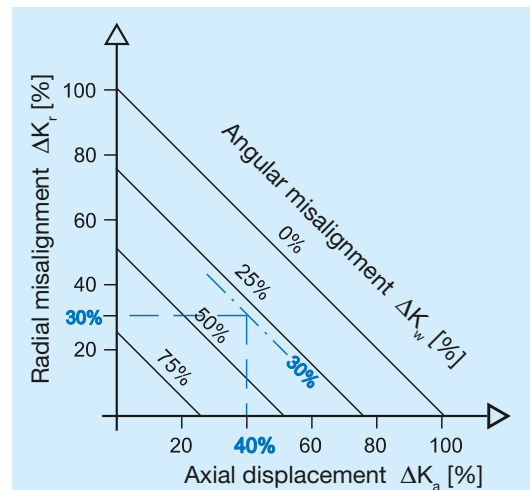

Fig. 2

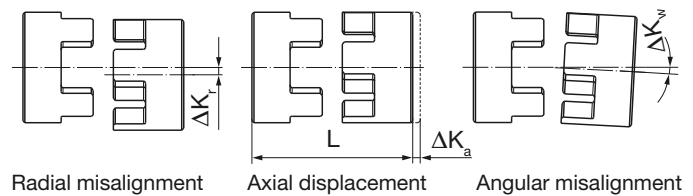

Fig. 3

Technical Explanations

State of Delivery

ROBA®-ES couplings are delivered manufacturer-assembled ready for installation.

The star-shaped intermediate ring is pressed into the specially designed claws (Fig. 4) under light pre-tension.

The principle of backlash-free torque transmission is possible due to this pre-tension.

ROBA®-ES couplings are delivered in four torque variations; that is with four different flexible intermediate rings varying in shore hardness and colour (see Type key page 24).

Due to the small structural dimensions and therefore the low mass moments of inertia, the device allows itself to be installed even into small installation spaces.

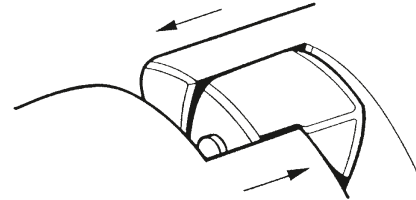

Fig. 4

Balancing

Key hubs and clamping hubs:

Key hubs and clamping hubs rotate at maximum speed with a circumferential speed of 30 m/s. They are not balanced for standard delivery.

Shrink disk hubs:

Shrink disk hubs maintain balance quality $G = 6.3$ up to speed n_G (equals approx. 30 m/s) without needing to be balanced. Above this speed, we recommend balancing. The hubs are balanced individually. Diagram 1 shows reference values. We recommend you use these values to balance the coupling components.

Smooth running of a machine or system is not only dependent on the balance quality of the coupling, but also on many parameters such as rigidity or distance to the adjacent bearing. Therefore there are no fixed rules in which conditions you have to balance.

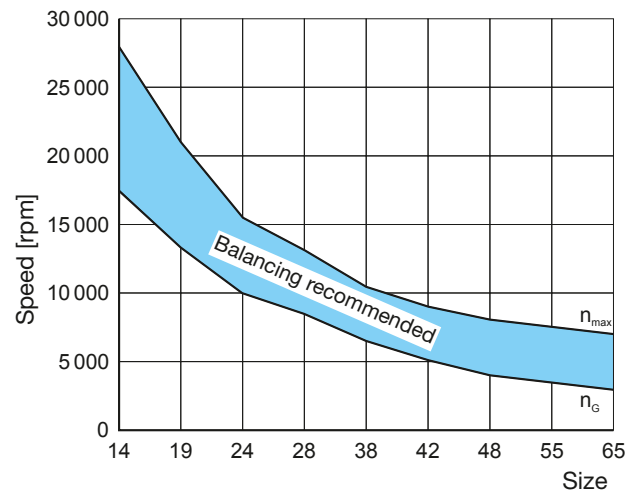

Diagram 1: Balancing the Shrink Disk Hubs



Headquarters

Chr. Mayr GmbH + Co. KG
Eichenstraße 1, D-87665 Mauerstetten
Tel.: +49 83 41/8 04-0, Fax: +49 83 41/80 44 21
www.mayr.com, E-Mail: info@mayr.com



your reliable partner

Service Germany/Austria

Baden-Württemberg

Esslinger Straße 7
 70771 Leinfelden-Echterdingen
 Tel.: 07 11/45 96 01 0
 Fax: 07 11/45 96 01 10

Bavaria

Industriestraße 51
 82194 Gröbenzell
 Tel.: 0 81 42/50 19 80-7

Chemnitz

Bornaer Straße 205
 09114 Chemnitz
 Tel.: 03 71/4 74 18 96
 Fax: 03 71/4 74 18 95

Franconia

Unterer Markt 9
 91217 Hersbruck
 Tel.: 0 91 51/81 48 64
 Fax: 0 91 51/81 62 45

Kamen

Herbert-Wehner-Straße 2
 59174 Kamen
 Tel.: 0 23 07/24 26 79
 Fax: 0 23 07/24 26 74

North

Schiefer Brink 8
 32699 Extertal
 Tel.: 0 57 54/9 20 77
 Fax: 0 57 54/9 20 78

Rhine-Main

Kreuzgrundweg 3a
 36100 Petersberg
 Tel.: 06 61/96 21 02 15

Austria

Pummerinplatz 1, TIZ I, A27
 4490 St. Florian, Österreich
 Tel.: 0 72 24/2 20 81-12
 Fax: 0 72 24/2 20 81 89

Branch Offices

China

Mayr Zhangjiagang
 Power Transmission Co., Ltd.
 Fuxin Road No.7, Yangshe Town
 215637 Zhangjiagang
 Tel.: 05 12/58 91-75 67
 Fax: 05 12/58 91-75 66
 info@mayr-ptc.cn

Great Britain

Mayr Transmissions Ltd.
 Valley Road, Business Park
 Keighley, BD21 4LZ
 West Yorkshire
 Tel.: 0 15 35/66 39 00
 Fax: 0 15 35/66 32 61
 sales@mayr.co.uk

France

Mayr France S.A.S.
 Z.A.L. du Minopole
 Rue Nungesser et Coli
 62160 Bully-Les-Mines
 Tel.: 03.21.72.91.91
 Fax: 03.21.29.71.77
 contact@mayr.fr

Italy

Mayr Italia S.r.l.
 Viale Veneto, 3
 35020 Saonara (PD)
 Tel.: 0498/79 10 20
 Fax: 0498/79 10 22
 info@mayr-italia.it

Singapore

Mayr Transmission (S) PTE Ltd.
 No. 8 Boon Lay Way Unit 03-06,
 TradeHub 21
 Singapore 609964
 Tel.: 00 65/65 60 12 30
 Fax: 00 65/65 60 10 00
 info@mayr.com.sg

Switzerland

Mayr Kupplungen AG
 Tobelackerstraße 11
 8212 Neuhausen am Rheinfall
 Tel.: 0 52/6 74 08 70
 Fax: 0 52/6 74 08 75
 info@mayr.ch

USA

Mayr Corporation
 10 Industrial Avenue
 Mahwah
 NJ 07430
 Tel.: 2 01/4 45-72 10
 Fax: 2 01/4 45-80 19
 info@mayrcorp.com

Turkey

Representative Office Türkei
 Kucukbakkalkoy Mah.
 Brandium Residence R2
 Blok D:254
 34750 Atasehir - Istanbul, Türkei
 Tel.: 02 16/2 32 20 44
 Fax: 02 16/5 04 41 72
 info@mayr.com.tr

Representatives

Australia

Drive Systems Pty Ltd.
 12 Sommersby Court
 Lysterfield, Victoria 3156
 Australia
 Tel.: 0 3/97 59 71 00
 dean.hansen@drivesystems.com.au

India

National Engineering
 Company (NENCO)
 J-225, M.I.D.C.
 Bhosari Pune 411026
 Tel.: 0 20/27 13 00 29
 Fax: 0 20/27 13 02 29
 nenco@nenco.org

Japan

MATSUI Corporation
 2-4-7 Azabudai
 Minato-ku
 Tokyo 106-8641
 Tel.: 03/35 86-41 41
 Fax: 03/32 24 24 10
 k.goto@matsui-corp.co.jp

Netherlands

Groneman BV
 Amarilstraat 11
 7554 TV Hengelo OV
 Tel.: 074/2 55 11 40
 Fax: 074/2 55 11 09
 aandrijftechniek@groneman.nl

Poland

Wamex Sp. z o.o.
 ul. Pozaryskiego, 28
 04-703 Warszawa
 Tel.: 0 22/6 15 90 80
 Fax: 0 22/8 15 61 80
 wamex@wamex.com.pl

South Korea

Mayr Korea Co. Ltd.
 15, Yeondeok-ro 9beon-gil
 Seongsan-gu
 51571 Changwon-si
 Gyeongsangnam-do. Korea
 Tel.: 0 55/2 62-40 24
 Fax: 0 55/2 62-40 25
 info@mayrkorea.com

Taiwan

German Tech Auto Co., Ltd.
 No. 28, Fenggong Zhong Road,
 Shengang Dist.,
 Taichung City 429, Taiwan R.O.C.
 Tel.: 04/25 15 05 66
 Fax: 04/25 15 24 13
 abby@zfgta.com.tw

Czech Republic

BMC - TECH s.r.o.
 Hviezdoslavova 29 b
 62700 Brno
 Tel.: 05/45 22 60 47
 Fax: 05/45 22 60 48
 info@bmc-tech.cz

More representatives:

Belgium, Brazil, Canada, Colombia, Croatia, Denmark, Finland, Greece, Hongkong, Hungary, Indonesia, Israel, Luxembourg, Malaysia, Mexico, New Zealand, Norway, Philippines, Portugal, Romania, Russia, Slovakia, Slovenia, South Africa, Spain, Sweden, Thailand

You can find the complete address for the representative responsible for your area under www.mayr.com in the internet.