

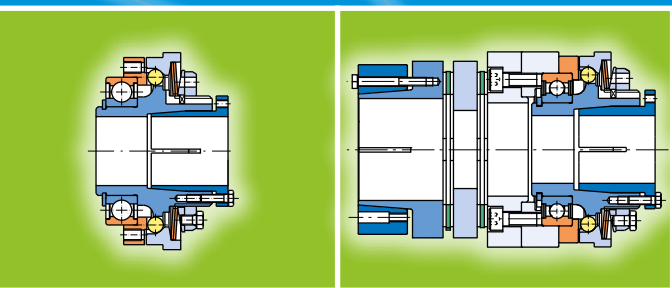

your reliable partner

EAS[®]-Compact[®]

**Backlash-free
Torque Limiting Clutches**



We safeguard the movements of this world



Specialists for power transmission for more than a century

mayr[®] power transmission is one of the most traditional and yet most innovative German companies in the field of power transmission. From modest beginnings in the year 1897, the family enterprise from the Allgäu region has developed into world market leader. Today, 550 employees work at the headquarters in Mauerstetten; more than 1000 employees work for the company worldwide.

Unsurpassed - our standard range

mayr[®] power transmission offers an extensive variety of torque limiters, safety brakes, backlash-free shaft misalignment compensation couplings and high-quality DC drives. Also when it comes to customer-specific requirements, the company possesses the expertise to develop customized and economical solutions. This is why numerous renowned machine manufacturers trust in holistic solutions by *mayr*[®] power transmission.

Available worldwide

With eight subsidiaries in Germany, sales offices in the USA, France, Great Britain, Italy, Singapore and Switzerland as well as 36 additional country representatives, *mayr*[®] is available in all important industrial areas, guaranteeing optimum customer service around the globe.

Never compromise on safety

We make no compromises where safety is concerned. Only top products of a perfect quality guarantee that no people are injured or machines damaged in case of operational malfunctions, collisions and other hazardous situations. The safety of your employees and machines is our motivation to always provide the best and most reliable clutches, couplings or brakes.

mayr[®] power transmission holds numerous ground-breaking patents, and is the global market or technological leader for

- application-optimised **safety brakes**, for example for passenger elevators, stage technology and gravity loaded axes
- **torque limiters** to protect against expensive overload damage and production losses and
- backlash-free **servo couplings**.

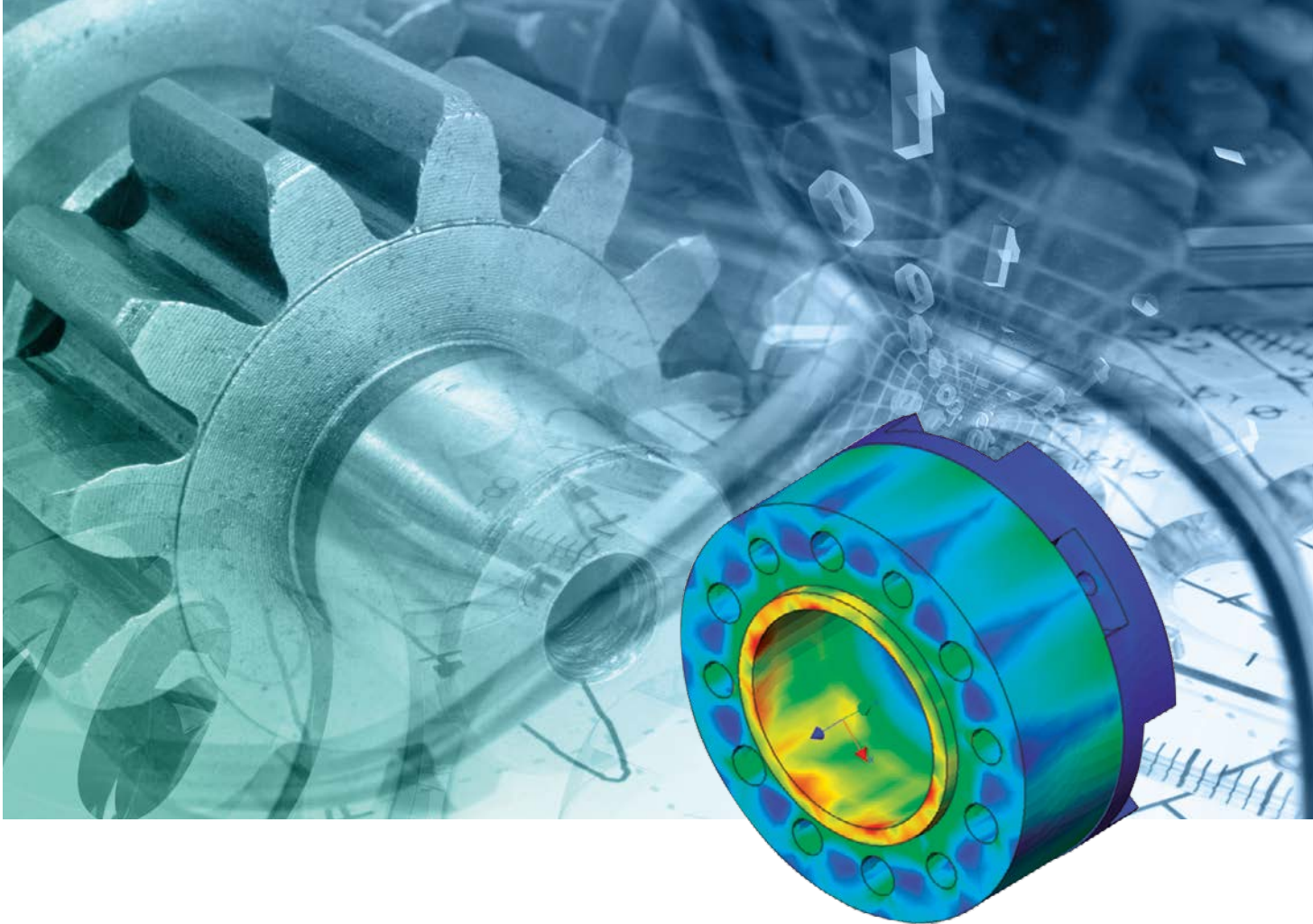

Tradition and innovation – the best of both worlds

Tradition and innovation do not contradict each other - on the contrary. They are the two supporting pillars which have guaranteed stability and reliability for generations. Long-term stability, independence as well as a good reputation and satisfied customers are important values for a family enterprise rich in tradition.

Therefore, we place emphasis on:

- Tested product quality
- Optimum customer service
- Comprehensive know-how
- Global presence
- Successful innovations
- Effective cost management

Following our own objective of always offering our customers the technologically most advanced and economical solution, we have been able to gain the trust of many leading industrial companies from all branches and from all over the world as a reliable partner.

Place your trust in our know-how and our more than 50 years of experience in torque limiters, safety brakes and shaft couplings.

Tested quality and reliability

mayr[®] products are subject to meticulous quality inspections. These include quality assurance measures during the construction process as well as a comprehensive final inspection. Only the best, tested quality leaves our factory. All products are rigorously tested on calibrated test stands, and adjusted precisely to the requested values. An electronic database in which the measurement values are archived together with the associated serial numbers guarantees 100 % traceability. On request, we confirm the product characteristics with a test protocol.

The certification of our quality management according to DIN EN ISO 9001:2000 confirms the quality-consciousness of our colleagues at every level of the company.

EAS[®]-Compact[®] - the economically viable protection for machines

Function

If the set limit torque is exceeded, the clutch disengages. The torque drops immediately. A mounted limit switch registers the disengagement movement and switches off the drive. The limit switch signal can also be used for further control functions.

After the malfunction has been rectified, the EAS[®]-Compact[®] ratchetting clutches and the EAS[®]-Compact[®] synchronous clutches automatically re-engage (for a detailed description of the re-engagement behaviour, see page 5). EAS[®]-Compact[®] overload clutches separate the input and the output side completely and remain in this state until they are intentionally re-engaged by hand or via a suitable device. A detailed description of the overload clutches starts on page 26.



The EAS[®]-Compact[®] matrix for success

Product characteristics	Your advantages	Your benefits
Backlash-free torque transmission	Long lifetime, Low wear	Lowest maintenance effort
Safe, readable torque adjustment	Simple installation and operation	Time-saving during initial operation
High performance density	Low mass moment of inertia, compact construction	High machine dynamic
Convenient torque course in the drive line on overload	Optimised dimensioning	Effective and efficient machine construction

EAS[®]-Compact[®] – the backlash-free principle

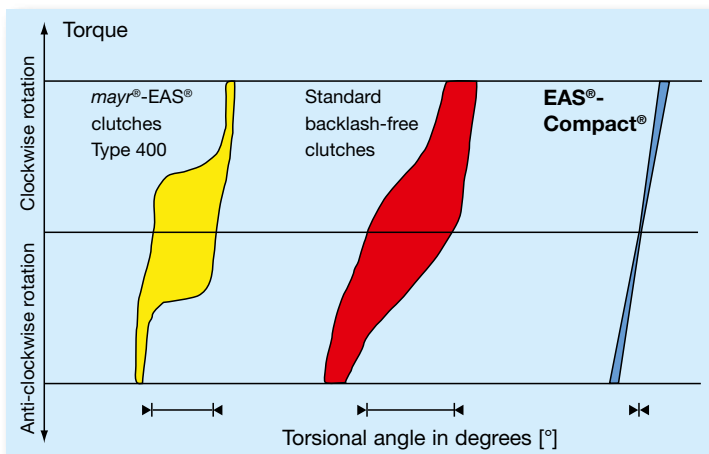

Backlash means:

- The torsional angle between the input and output of the clutch
- Also known as a “torsional backlash”
- Not to be confused with the transmission backlash from the shaft onto the hub
- **At mayr[®], backlash-free means: Backlash → 0** (see diagram)

EAS[®]-Compact[®]/EAS[®]-NC Ratchetting clutch

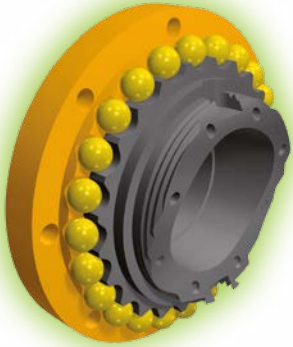

- When the set limit torque is reached, the clutch disengages; the torque drops immediately.
- The clutch ratchets.
- After the cause of overload has been removed, the clutch automatically re-engages into the next of the series of ball detents.
- The clutch is ready for operation again.

EAS[®]-Compact[®]/EAS[®]-NC Synchronous clutch

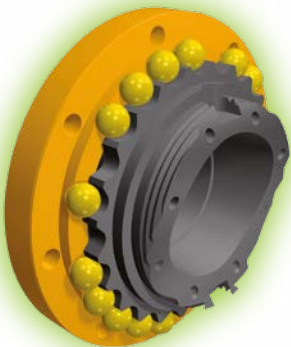

- When the set limit torque is reached, the clutch disengages; the torque drops immediately.
- After the cause of overload has been removed, the clutch re-engages automatically after 360 angular degrees. Other cycle sequences, for example 180 degrees, are also available.
- The clutch is ready for operation again.

EAS[®]-Compact[®] overload clutch

If overload occurs, the EAS[®]-Compact[®] overload clutches separate the input and output almost residual torque-free. Therefore, they are the ideal protective element for fast-running drives and high mass moments of inertia.

A detailed description starts on **page 26**.

Contents

	Page
EAS[®]-Compact[®] ratchetting clutches	
EAS[®]-Compact[®] synchronous clutches	
<i>Torque range: 5 to 1500 Nm</i>	
Description	5
Summary of constructional designs	6
Data sheets	
• EAS [®] -Compact [®] short hub	8
• EAS [®] -Compact [®] double bearing design	10
• EAS [®] -Compact [®] long protruding hub	12
• EAS [®] -Compact [®] with steel bellows coupling	14
• EAS [®] -Compact [®] torsionally rigid	16
• EAS [®] -Compact [®] lastic backlash-free	18
 <i>For small torques:</i>	
EAS[®]-NC ratchetting clutches	
EAS[®]-NC synchronous clutches	
<i>Torque range: 0.65 to 15 Nm</i>	
Data sheets	
• EAS [®] -NC short hub	20
• EAS [®] -NC long protruding hub	20
• EAS [®] -NC double bearing design	22
• EAS [®] -NC with steel bellows coupling	24
 EAS[®]-Compact[®] overload clutches	
<i>Torque range: 5 to 3000 Nm</i>	
Description	26
Summary of constructional designs	27
Data sheets	
• EAS [®] -Compact [®] overload short hub	28
• EAS [®] -Compact [®] overload long protruding hub	30
• EAS [®] -Compact [®] overload torsionally rigid, Sizes 01 to 3	32
• EAS [®] -Compact [®] overload torsionally rigid, Sizes 4 and 5	34
• EAS [®] -Compact [®] overload lastic backlash-free	36
• EAS [®] -Compact [®] overload lastic	40
 EAS [®] -Compact [®] Options	42
Technical Explanations	44
Frictionally-Locking Transmittable Torques	50
Limit Switch	51
Installation Examples	54

Summary of constructional designs EAS®-Compact® ratchetting clutch/synchronous clutch

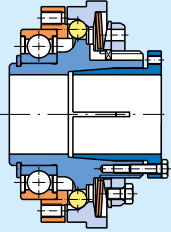
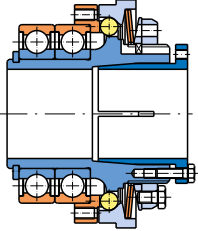
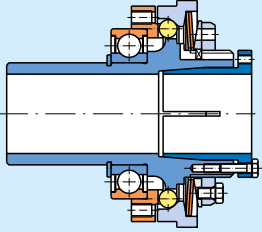
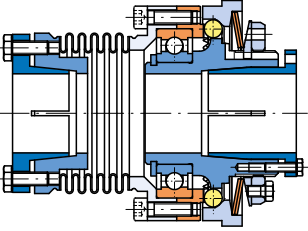
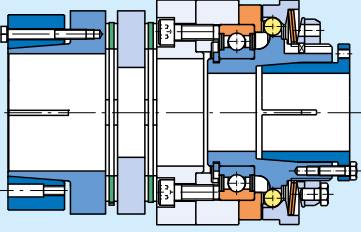
<p>EAS®-Compact® short hub</p> 	<p>Torque: 5 to 1500 Nm</p> <p>Sizes 01 to 4 Type 490.____0</p> <p>Also available in rustproof design!</p>	<ul style="list-style-type: none"> Flange clutch for direct installation of the drive element with the resulting radial force approximately in the bearing centre See installation example, Fig. 1, page 54 <p>With cone bushing Type 490._1_.0 With keyway Type 490._2_.0</p> <p style="text-align: right;">Page 8</p>
<p>EAS®-Compact® double bearing design</p> 	<p>Torque: 5 to 1500 Nm</p> <p>Sizes 01 to 4 Type 490.____2</p>	<ul style="list-style-type: none"> Flange clutch with a stable, double bearing for the drive element <p>With cone bushing Type 490._1_.2 With keyway Type 490._2_.2</p> <p style="text-align: right;">Page 10</p>
<p>EAS®-Compact® long protruding hub</p> 	<p>Torque: 5 to 1500 Nm</p> <p>Sizes 01 to 4 Type 490.____1</p>	<ul style="list-style-type: none"> Flange clutch for very wide drive elements or elements with a very small diameter Suitable bearings for the drive element are ball bearings, needle bearings or plain bearings. See installation example, Fig. 2, page 54 <p>With cone bushing Type 490._1_.1 With keyway Type 490._2_.1</p> <p style="text-align: right;">Page 12</p>
<p>EAS®-Compact® with steel bellows coupling</p> 	<p>Torque: 5 to 350 Nm</p> <p>Sizes 01 to 3 Type 493.____0</p>	<ul style="list-style-type: none"> Double shaft design with a torsionally rigid steel bellows coupling Compensation for axial, radial and angular shaft misalignments See installation example, Fig. 4, page 54 <p>Hub designs: <u>EAS®-side/steel bellows-side</u> Cone bushing/cone bushing Type 493._1_.0 Key hub/key hub Type 493._2_.0 Cone bushing/clamping hub Type 493._3_.0</p> <p style="text-align: right;">Page 14</p>
<p>EAS®-Compact® torsionally rigid</p> 	<p>Torque: 5 to 1500 Nm</p> <p>Sizes 01 to 4 Type 496.____0</p>	<ul style="list-style-type: none"> Double shaft design with a robust disk pack coupling Compensation for axial, radial and angular shaft misalignments High torsional rigidity <p>Hub designs: <u>EAS®-side/torsionally rigid side</u> Cone bushing/shrink disk hub Type 496._1_.0 Key hub/clamping hub Type 496._2_.0 Key hub/key hub Type 496._2_.0</p> <p style="text-align: right;">Page 16</p>

Summary of constructional designs EAS®-Compact® ratchetting clutch/synchronous clutch

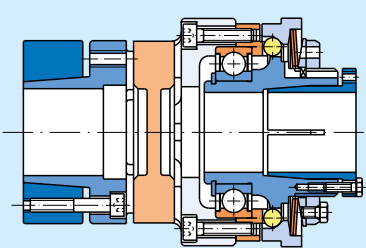
<p>EAS®-Compact® lastic backlash-free</p> 	<p>Torque: 5 to 1200 Nm</p> <p>Sizes 01 to 4 Type 494.____</p>	<ul style="list-style-type: none"> • Double shaft design with a flexible, backlash-free coupling • Compensation for axial, radial and angular shaft misalignments • High damping characteristics <p>See installation example, Fig. 3, page 54</p> <p>Hub designs: <u>EAS®-side/flexible side</u> Cone bushing/clamping hub Type 494._0_._ Cone bushing/shrink disk hub Type 494._1_._ Key hub/key hub Type 494._2_._</p> <p style="text-align: right;">Page 18</p>
--	--	--

Summary of constructional designs EAS®-NC miniature clutch

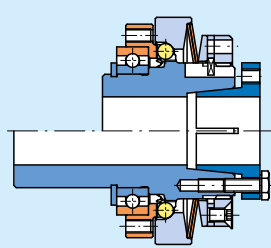
<p>EAS®-NC short hub EAS®-NC long protruding hub</p> 	<p>Torque: 0.65 to 15 Nm</p> <p>Sizes 03 and 02 Type 450.____</p>	<p>EAS®-NC short hub</p> <ul style="list-style-type: none"> • Flange clutch for direct installation of drive elements with the resulting radial force approximately in the bearing centre <p>With cone bushing Type 450._1_._0 With keyway Type 450._2_._0</p> <p>EAS®-NC long protruding hub</p> <ul style="list-style-type: none"> • Flange clutch for very wide drive elements or elements with a very small diameter <p>With cone bushing Type 450._1_._1 With keyway Type 450._2_._1</p> <p style="text-align: right;">Page 20</p>
--	---	--

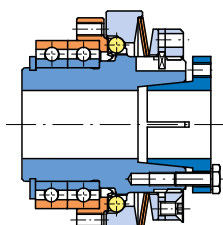
<p>EAS®-NC double bearing design</p> 	<p>Torque: 0.65 to 15 Nm</p> <p>Sizes 03 and 02 Type 450.____2</p>	<ul style="list-style-type: none"> • Flange clutch with a stable, double bearing for the drive element <p>With cone bushing Type 450._1_._2 With keyway Type 450._2_._2</p> <p style="text-align: right;">Page 22</p>
--	--	--

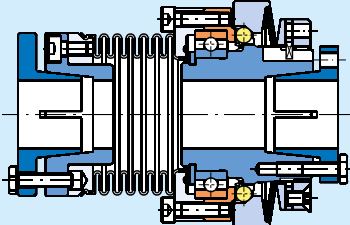
<p>EAS®-NC with steel bellows coupling</p> 	<p>Torque: 0.65 to 15 Nm</p> <p>Sizes 03 and 02 Type 453.____0</p>	<ul style="list-style-type: none"> • Double shaft design with a torsionally rigid steel bellows coupling • Compensation for axial, radial and angular shaft misalignments <p>Hub designs: <u>EAS®-side/steel bellows-side</u> Cone bushing/cone bushing Type 453._1_._0 Key hub/key hub Type 453._2_._0</p> <p style="text-align: right;">Page 24</p>
--	--	--

EAS[®]-Compact[®] ratchetting clutch/synchronous clutch

EAS[®]-Compact[®] short hub with cone bushing

Type 490._1_.0

Sizes 01 to 4

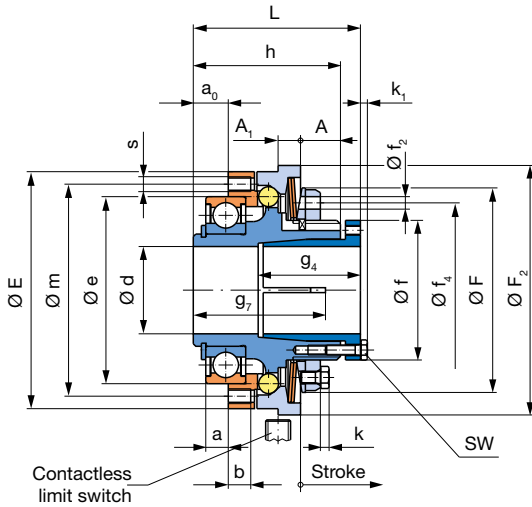

For information on rustproof designs, please order catalogue!

EAS[®]-Compact[®] short hub with keyway

Type 490._2_.0

Sizes 01 to 4

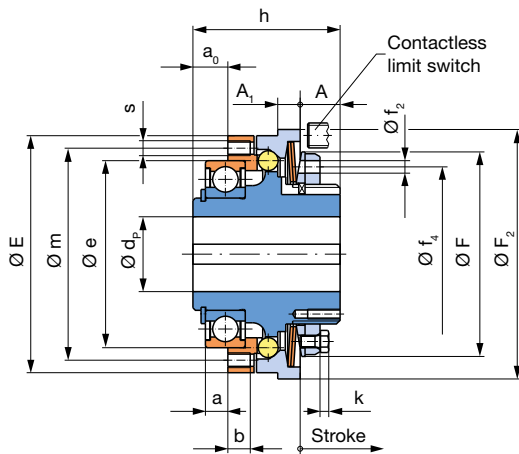

For information on rustproof designs, please order catalogue!

Order Number

		with cone bushing	1	0	Ratchetting clutch ³⁾	Torque adjustment value (Optional)	
		with keyway	2	5	Synchronous clutch		
			▼	▼		▼	
		_ / 4 9 0 . _ _ . 0 / _ / _ / _ / _					
		▲	▲	▲	▲	▲	▲
Sizes	Torque range ¹⁾		5		Hub bore	With limit switch	Radial torque adjustment
01	medium		6		bore	see	see
to	high		7		Ø d ^{H7}	pages 51 – 53	page 42
4	very high		8		Ø d _P ^{H7}	(Option)	(Option)
	maximum ²⁾						

Example: Order number 1 / 490.620.0 / 25 / 60 / limit switch 055.002.5 / radial adjustment

- 1) See Technical Data, limit torque for overload M_G
- 2) Max. torque range only available as synchronous clutch, speed < 250 rpm
- 3) Standard ratchetting division is 15°; other ratchetting divisions optionally available (45°/60°/90°/120°/180°/...)

EAS®-Compact® ratchetting clutch/synchronous clutch

Technical Data				Size ¹⁾					
				01	0	1	2	3	4
Limit torques for overload ¹⁾²⁾	Type 490.5_..0	M _G	[Nm]	5 – 12.5	10 – 25	20 – 50	40 – 100	70 – 175	120 – 300
	Type 490.6_..0	M _G	[Nm]	10 – 25	20 – 50	40 – 100	80 – 200	140 – 350	240 – 600
	Type 490.7_..0	M _G	[Nm]	20 – 50	40 – 100	80 – 200	160 – 400	280 – 700	480 – 1200
	Type 490.8_ 5.0 ¹¹⁾	M _G	[Nm]	25 – 62.5	50 – 125	100 – 250	200 – 500	350 – 875	600 – 1500
Max. speed	n _{max}	[rpm]		4000	3000	2500	2000	1200	800
Thrust washer stroke on overload		[mm]		1.2	1.5	1.8	2.0	2.2	2.5

Mass moments of inertia and weights				Size					
				01	0	1	2	3	4
Hub-side	Type 490_ 1_..0	I	[10 ⁻³ kgm ²]	0.211	0.531	1.388	2.846	6.858	29.432
	Type 490_ 2_..0	I	[10 ⁻³ kgm ²]	0.205	0.505	1.302	2.630	6.329	28.443
Pressure flange-side	Type 490_ 1_..0	I	[10 ⁻³ kgm ²]	0.093	0.234	0.643	1.306	2.649	6.690
	Type 490_ 2_..0	I	[10 ⁻³ kgm ²]	0.093	0.234	0.643	1.306	2.649	6.690
Weights	Type 490_ 1_..0	m	[kg]	0.68	1.14	1.98	2.88	4.59	10.63
	Type 490_ 2_..0	m	[kg]	0.63	1.02	1.75	2.55	4.07	10.06

Tensioning screws and screw-on bores				Size					
				01	0	1	2	3	4
Tensioning screws in cone bushing	Number, dimensions	M	[mm]	6 x M4	6 x M4	8 x M4	8 x M5	8 x M6	8 x M8
	Wrench opening	SW	[mm]	7	7	7	8	10	13
	Tightening torque	T _A	[Nm]	4	4	4	8	12	25
Screw-on bores in pressure flange	Number, dimensions	s	[mm]	8 x M4	8 x M5	8 x M6	8 x M6	8 x M8	8 x M10
	Screws quality class 12.9 must be used to secure the drive element.								

Dimensions [mm]	Size						
	01	0	1	2	3	4	
A	12	13.5	16	17	20.5	46	
A ₁	7	8	9	10	12	16	
a ⁵⁾	5	7	9	10	10	12	
a ₀	8	11	14	16	18	21	
b	6	7	9	10	12	15	
E	65	80	95	110	130	166	
e _{h5} ⁶⁾	47	62	75	90	100	130	
F	61.5	67	82	97	117	150	
F ₂	70	85	100	115	135	166	
f	38	44	56	70	84	100	
f ₂	5	5	5	6	7	-	
f ₄	50	55	70	84	100	-	
Minimum shaft length	g ₄	34	39	42	48	53	93
	g ₇	31	36	48	49	62	78
h	40	48	59	64	75	115	
k	2.8	2.8	3.5	4.0	4.0	-	
k ₁	2.8	2.8	2.8	3.5	4.0	5.3	
L ⁷⁾	47	56	67	73	86	130	
m	56	71	85	100	116	150	

Bores [mm]		Size					
		01	0	1	2	3	4
d ²⁾³⁾⁴⁾	d _{min}	10	15	22	32	35	40
	d _{max}	20	25	35	45	55	65
d _P ²⁾¹⁰⁾	d _{P min} ⁸⁾	12	15	22	28	32	40
	d _{P max} ⁹⁾	20	25	30	40	50	65

We reserve the right to make dimensional and constructional alterations.

- 1) Further sizes for smaller and larger torques available on request
- 2) Please observe the shaft load in max. torque range.
- 3) Shaft tolerance up to Ø 38_{H6} over Ø 38_{H8}
- 4) Transmittable torques available with smaller bores on request
- 5) Mounting tolerance + 0.1
- 6) Tolerance user-side H7
- 7) Dimensions in untensioned condition (shorter in tensioned condition)
- 8) Smaller bores for low torques available on request
- 9) Larger bores available on request
- 10) The position of the keyway to the mounting bore "s" in the pressure flange is not defined. Defined position available on request
- 11) Maximum speed: 250 rpm

EAS®-Compact® ratchetting clutch/synchronous clutch

EAS®-Compact® double bearing design with cone bushing

Type 490_1_2

Sizes 01 to 4

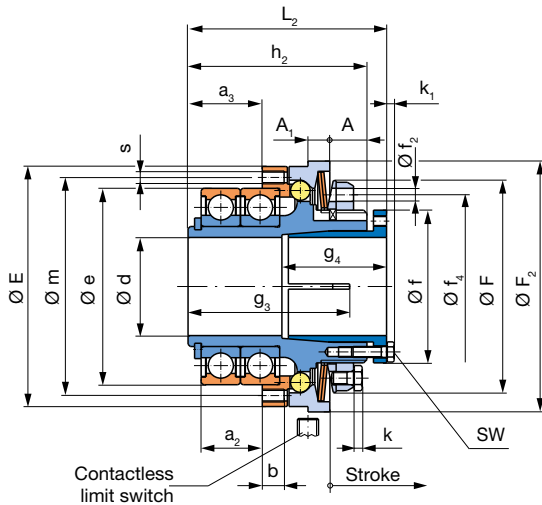

EAS®-Compact® double bearing design with keyway

Type 490_2_2

Sizes 01 to 4

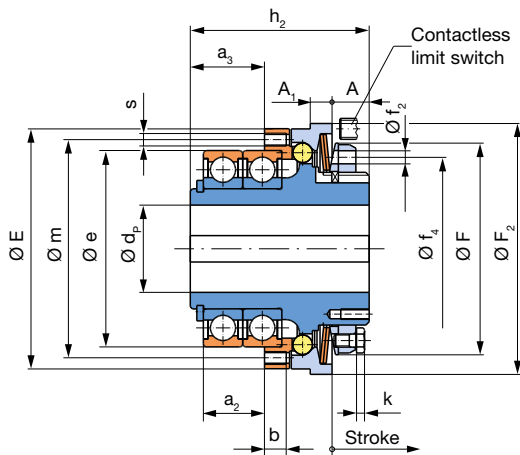

Order Number

with cone bushing		1	0	Ratchetting clutch ³⁾	Torque adjustment value (Optional)	With limit switch see pages 51 – 53 (Option)
with keyway		2	5	Synchronous clutch		
Sizes	Torque range ¹⁾		2-bearing design	2	Hub bore Ø d ^{H7} Ø d _p ^{H7}	Radial torque adjustment see page 42 (Option)
01 to 4	medium high very high maximum ²⁾	5 6 7 8				

Example: Order number 1 / 490.610.2 / 25 / 60 / limit switch 055.002.5 / radial adjustment

1) See Technical Data, limit torque for overload M_G
 2) Max. torque range only available as synchronous clutch, speed < 250 rpm
 3) Standard ratchetting division is 15°; other ratchetting divisions optionally available (45°/60°/90°/120°/180°/...)

EAS®-Compact® ratchetting clutch/synchronous clutch

Technical Data				Size ¹⁾					
				01	0	1	2	3	4
Limit torques for overload ¹⁾²⁾	Type 490.5_..2	M _G	[Nm]	5 – 12.5	10 – 25	20 – 50	40 – 100	70 – 175	120 – 300
	Type 490.6_..2	M _G	[Nm]	10 – 25	20 – 50	40 – 100	80 – 200	140 – 350	240 – 600
	Type 490.7_..2	M _G	[Nm]	20 – 50	40 – 100	80 – 200	160 – 400	280 – 700	480 – 1200
	Type 490.8_ 5.2 ¹⁾	M _G	[Nm]	25 – 62.5	50 – 125	100 – 250	200 – 500	350 – 875	600 – 1500
Max. speed	n _{max}	[rpm]		4000	3000	2500	2000	1200	800
Thrust washer stroke on overload		[mm]		1.2	1.5	1.8	2.0	2.2	2.5

Mass moments of inertia and weights				Size					
				01	0	1	2	3	4
Hub-side	Type 490_..1_..2	I	[10 ⁻³ kgm ²]	0215	0.552	1.450	2.998	7.081	30.990
	Type 490_..2_..2	I	[10 ⁻³ kgm ²]	0.209	0.526	1.364	2.782	6.552	30.000
Pressure flange-side	Type 490_..1_..2	I	[10 ⁻³ kgm ²]	0.100	0.273	0.799	1.675	3.162	8.570
	Type 490_..2_..2	I	[10 ⁻³ kgm ²]	0.100	0.273	0.799	1.675	3.162	8.570
Weights	Type 490_..1_..2	m	[kg]	0.79	1.35	2.35	3.45	5.27	11.96
	Type 490_..2_..2	m	[kg]	0.74	1.23	2.12	3.12	4.75	11.35

Tensioning screws and screw-on bores				Size					
				01	0	1	2	3	4
Tensioning screws in cone bushing	Number, dimensions	M	[mm]	6 x M4	6 x M4	8 x M4	8 x M5	8 x M6	8 x M8
	Wrench opening	SW	[mm]	7	7	7	8	10	13
	Tightening torque	T _A	[Nm]	4	4	4	8	12	25
Screw-on bores in pressure flange	Number, dimensions	s	[mm]	8 x M4	8 x M5	8 x M6	8 x M6	8 x M8	8 x M10
	Screws quality class 12.9 must be used to secure the drive element.								

Dimensions [mm]	Size						
	01	0	1	2	3	4	
A	12	13.5	16	17	20.5	46	
A ₁	7	8	9	10	12	16	
a ₂ ⁵⁾	14	19	25	28	28	34	
a ₃	17	23	30	34	36	43	
b	6	7	9	10	12	15	
E	65	80	95	110	130	166	
e _{h5} ⁶⁾	47	62	75	90	100	130	
F	61.5	67	82	97	117	150	
F ₂	70	85	100	115	135	166	
f	38	44	56	70	84	100	
f ₂	5	5	5	6	7	-	
f ₄	50	55	70	84	100	-	
Minimum shaft length	g ₃	40	48	63	67	80	100
	g ₄	34	39	42	48	53	93
h ₂	49	60	75	82	93	137	
k	2.8	2.8	3.5	4.0	4.0	-	
k ₁	2.8	2.8	2.8	3.5	4.0	5.3	
L ₂ ⁷⁾	56	68	83	91	104	152	
m	56	71	85	100	116	150	

Bores [mm]	Size						
	01	0	1	2	3	4	
d ²⁾³⁾⁴⁾	d _{min}	10	15	22	32	35	40
	d _{max}	20	25	35	45	55	65
d _P ²⁾¹⁰⁾	d _{P min} ⁸⁾	12	15	22	28	32	40
	d _{P max} ⁹⁾	20	25	30	40	50	65

We reserve the right to make dimensional and constructional alterations.

- 1) Further sizes for smaller and larger torques available on request
- 2) Please observe the shaft load in max. torque range.
- 3) Shaft tolerance up to $\varnothing 38_{h6}$, over $\varnothing 38_{h8}$
- 4) Transmittable torques available with smaller bores on request
- 5) Mounting tolerance + 0.1
- 6) Tolerance user-side H7
- 7) Dimensions in untensioned condition (shorter in tensioned condition)
- 8) Smaller bores for low torques available on request
- 9) Larger bores available on request
- 10) The position of the keyway to the mounting bore "s" in the pressure flange is not defined. Defined position available on request
- 11) Maximum speed: 250 rpm

EAS[®]-Compact[®] ratchetting clutch/synchronous clutch

EAS[®]-Compact[®] long protruding hub with cone bushing

Type 490.1.1
Sizes 01 to 4

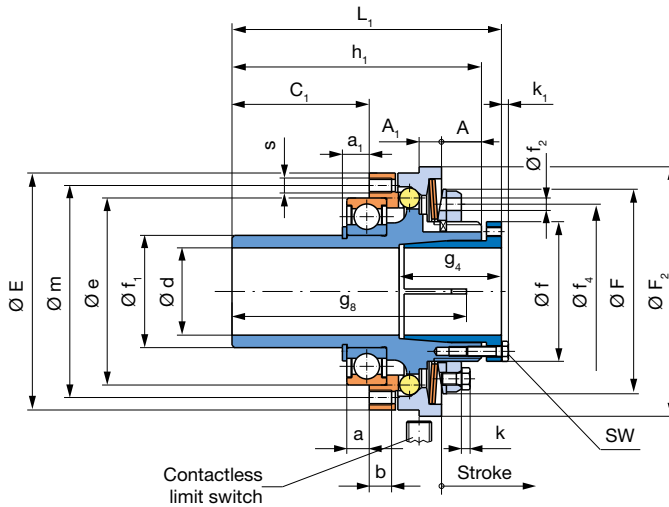

EAS[®]-Compact[®] long protruding hub with keyway

Type 490.2.1
Sizes 01 to 4

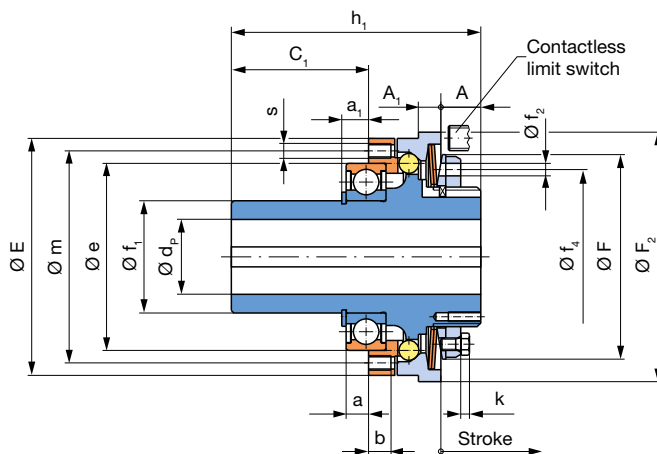

Order Number

with cone bushing		1	0	Ratchetting clutch ³⁾	Torque adjustment value (Optional)	With limit switch see pages 51 – 53 (Option)
with keyway		2	5	Synchronous clutch		
__ / 4 9 0 . __ __ . 1 / __ / __ / __ / __						
Sizes	Torque range¹⁾		long protruding hub	1	Hub bore	Radial torque adjustment see page 42 (Option)
01	medium	5			Ø d ^{H7}	
to	high	6			Ø d _p ^{H7}	
4	very high maximum ²⁾	7 8				

Example: Order number 1 / 490.610.1 / 25 / 60 / limit switch 055.002.5 / radial adjustment

- 1) See Technical Data, limit torque for overload M_G
- 2) Max. torque range only available as synchronous clutch, speed < 250 rpm
- 3) Standard ratchetting division is 15°; other ratchetting divisions optionally available (45°/60°/90°/120°/180°/...)

EAS®-Compact® ratchetting clutch/synchronous clutch

Technical Data				Size ¹⁾					
				01	0	1	2	3	4
Limit torques for overload ¹⁾²⁾	Type 490.5_._1	M _G	[Nm]	5 – 12.5	10 – 25	20 – 50	40 – 100	70 – 175	120 – 300
	Type 490.6_._1	M _G	[Nm]	10 – 25	20 – 50	40 – 100	80 – 200	140 – 350	240 – 600
	Type 490.7_._1	M _G	[Nm]	20 – 50	40 – 100	80 – 200	160 – 400	280 – 700	480 – 1200
	Type 490.8_ 5.1 ¹¹⁾	M _G	[Nm]	25 – 62.5	50 – 125	100 – 250	200 – 500	350 – 875	600 – 1500
Max. speed	n _{max}	[rpm]		4000	3000	2500	2000	1200	800
Thrust washer stroke on overload		[mm]		1.2	1.5	1.8	2.0	2.2	2.5

Mass moments of inertia and weights				Size					
				01	0	1	2	3	4
Hub-side	Type 490_1_1	I	[10 ⁻³ kgm ²]	0.225	0.588	1.491	3.105	7.350	30.890
	Type 490_2_1	I	[10 ⁻³ kgm ²]	0.219	0.562	1.405	2.889	6.851	29.900
Pressure flange-side	Type 490_1_1	I	[10 ⁻³ kgm ²]	0.093	0.234	0.643	1.306	2.649	6.690
	Type 490_2_1	I	[10 ⁻³ kgm ²]	0.093	0.234	0.643	1.306	2.649	6.690
Weights	Type 490_1_1	m	[kg]	0.78	1.36	2.26	3.34	5.18	11.65
	Type 490_2_1	m	[kg]	0.73	1.24	2.04	3.00	4.66	11.04

Tensioning screws and screw-on bores				Size					
				01	0	1	2	3	4
Tensioning screws in cone bushing	Number, dimensions	M	[mm]	6 x M4	6 x M4	8 x M4	8 x M5	8 x M6	8 x M8
	Wrench opening	SW	[mm]	7	7	7	8	10	13
	Tightening torque	T _A	[Nm]	4	4	4	8	12	25
Screw-on bores in pressure flange	Number, dimensions	s	[mm]	8 x M4	8 x M5	8 x M6	8 x M6	8 x M8	8 x M10
	Screws quality class 12.9 must be used to secure the drive element.								

Dimensions [mm]	Size						
	01	0	1	2	3	4	
A	12	13.5	16	17	20.5	46	
A ₁	7	8	9	10	12	16	
a ⁵⁾	5	7	9	10	10	12	
a ₁	6.5	8.75	11.5	13	14	16	
b	6	7	9	10	12	15	
C ₁	33	43	55	67	73	76	
E	65	80	95	110	130	166	
e _{h5} ⁶⁾	47	62	75	90	100	130	
F	61.5	67	82	97	117	150	
F ₂	70	85	100	115	135	166	
f	38	44	56	70	84	100	
f _{1h6}	30	40	45	55	65	85	
f ₂	5	5	5	6	7	-	
f ₄	50	55	70	84	100	-	
Minimum shaft length	g ₄	34	39	42	48	53	93
	g ₈	56	68	89	100	117	133
h ₁	65	80	100	115	130	170	
k	2.8	2.8	3.5	4.0	4.0	-	
k ₁	2.8	2.8	2.8	3.5	4.0	5.3	
L ₁ ⁷⁾	72	88	108	124	141	185	
m	56	71	85	100	116	150	

Bores [mm]	Size						
	01	0	1	2	3	4	
d ²⁾³⁾⁴⁾	d _{min}	10	15	22	32	35	40
	d _{max}	20	25	35	45	55	65
d _p ²⁾¹⁰⁾	d _{p min} ⁸⁾	12	15	22	28	32	40
	d _{p max} ⁹⁾	20	25	30	40	50	65

We reserve the right to make dimensional and constructional alterations.

- 1) Further sizes for smaller and larger torques available on request
- 2) Please observe the shaft load in max. torque range.
- 3) Shaft tolerance up to $\varnothing 38_{h6}$ over $\varnothing 38_{h8}$
- 4) Transmittable torques available with smaller bores on request
- 5) Mounting tolerance + 0.1
- 6) Tolerance user-side H7
- 7) Dimensions in untensioned condition (shorter in tensioned condition)
- 8) Smaller bores for low torques available on request
- 9) Larger bores available on request
- 10) The position of the keyway to the mounting bore "s" in the pressure flange is not defined. Defined position available on request
- 11) Maximum speed: 250 rpm

EAS®-Compact® ratchetting clutch/synchronous clutch

EAS®-Compact® with steel bellows coupling

Type 493.____.0
 Sizes 01 to 3

EAS®-side cone bushing,
 Steel bellows-side cone bushing
 Type 493.1_0

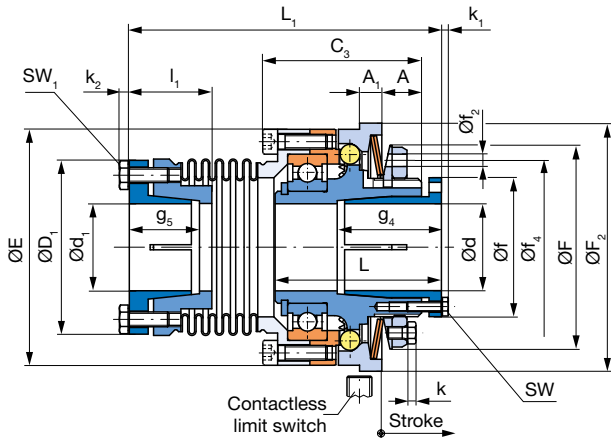

EAS®-side cone bushing,
 Steel bellows-side clamping hub
 Type 493.3_0

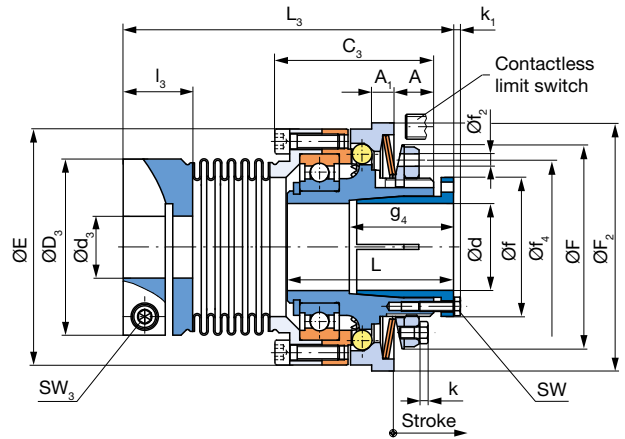

EAS®-side key hub,
 Steel bellows-side key hub
 Type 493.2_0

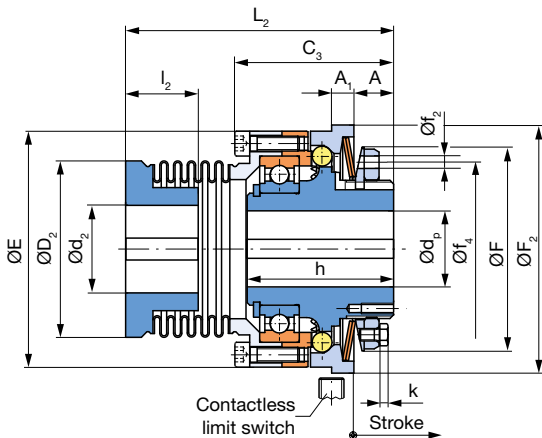

Order Number

EAS®-side	Steel bellows-side				Torque adjustment value (Optional)	With limit switch see pages 51 – 53 (Option)
Cone bushing	Cone bushing	1	0	Ratchetting clutch ²⁾		
Key hub	Key hub	2	5	Synchronous clutch		
Cone bushing	Clamping hub	3				

___ / 4 9 3 . ___ ___ . 0 / ___ / ___ / ___ / ___ / ___

Sizes 01 to 3	Torque range ¹⁾ medium to high	5 to 6	Hub 1 bore $\varnothing d^{H7}$ $\varnothing d_p^{H7}$	Hub 2 bore $\varnothing d_1^{H7}$ $\varnothing d_2^{H7}$ $\varnothing d_3^{H7}$	Radial torque adjustment see page 42 (Option)
---------------	---	--------	--	---	---

Example: Order number 1 / 493.615.0 / 22 / 25 / 60 / limit switch 055.002.5 / radial adjustment

1) See Technical Data, limit torque for overload M_G
 2) Standard ratchetting division is 15°; other ratchetting divisions optionally available (45°/60°/90°/120°/180°/...)

EAS®-Compact® ratchetting clutch/synchronous clutch

Technical Data				Size ¹⁾				
				01	0	1	2	3
Limit torques for overload ¹⁾	Type 493.5__0	M _G	[Nm]	5 – 12.5	10 – 25	20 – 50	40 – 100	70 – 175
	Type 493.6__0	M _G	[Nm]	10 – 25	20 – 50	40 – 100	80 – 200	140 – 350
Max. speed		n _{max}	[rpm]	4000	3000	2500	2000	1200
Thrust washer stroke on overload			[mm]	1.2	1.5	1.8	2.0	2.2
Nominal torques, steel bellows coupling		T _{KN}	[Nm]	50	100	200	350	600
Permitted misalignments	axial	ΔK _a	[mm]	0.4	0.6	0.8	1.0	1.0
	radial	ΔK _r	[mm]	0.15	0.15	0.20	0.25	0.30
	angular	ΔK _w	[°]	2	2	2	2	2

Mass moments of inertia and weights				Size				
				01	0	1	2	3
EAS®-hub-side	Type 493._1_0	I	[10 ⁻³ kgm ²]	0.211	0.531	1.388	2.846	6.858
	Type 493._2_0	I	[10 ⁻³ kgm ²]	0.205	0.505	1.302	2.630	6.359
	Type 493._3_0	I	[10 ⁻³ kgm ²]	0.211	0.531	1.388	2.846	6.858
Steel bellows-side	Type 493._1_0	I	[10 ⁻³ kgm ²]	0.269	0.753	1.764	3.602	7.789
	Type 493._2_0	I	[10 ⁻³ kgm ²]	0.249	0.690	1.546	3.018	6.818
	Type 493._3_0	I	[10 ⁻³ kgm ²]	0.286	0.789	1.772	3.773	8.087
Weights	Type 493._1_0	m	[kg]	1.09	1.88	3.08	4.60	7.19
	Type 493._2_0	m	[kg]	1.04	1.76	2.85	4.27	6.90
	Type 493._3_0	m	[kg]	1.22	1.91	3.10	4.65	7.12

Tensioning screws				Size				
				01	0	1	2	3
In cone bushing EAS®-side	Number, dimensions	M	[mm]	6 x M4	6 x M4	8 x M4	8 x M5	8 x M6
	Wrench opening	SW	[mm]	7	7	7	8	10
	Tightening torque	T _A	[Nm]	4	4	4	8	12
In cone bushing steel bellows-side	Number, dimensions	M ₁	[mm]	4 x M4	6 x M5	6 x M6	6 x M8	6 x M8
	Wrench opening	SW ₁	[mm]	7	8	10	13	13
	Tightening torque	T _A	[Nm]	3	5	9.5	17	17
In clamping hub steel bellows-side	Number, dimensions	M ₃	[mm]	1 x M5	1 x M6	1 x M6	1 x M8	1 x M10
	Wrench opening	SW ₃	[mm]	4	5	5	6	8
	Tightening torque	T _A	[Nm]	10	18	18	43	87

Dimensions [mm]		Size				
		01	0	1	2	3
A		12	13.5	16	17	20.5
A ₁		7	8	9	10	12
C ₃		45	53	64	70	81
D ₁		47	60	70	81	98
D ₂		47	60	71	81	98
D ₃		50	60	71	82	98
E		65	80	95	110	130
F		61.5	67	82	97	117
F ₂		70	85	100	115	135
f		38	44	56	70	84
f ₂		5	5	5	6	7
f ₄		50	55	70	84	100
Minimum shaft length	g ₄	34	39	42	48	53
	g ₅	24	27	29	32	35
	l ₃	24	28	28	36	40
h		40	48	59	64	75
k		2.8	2.8	3.5	4.0	4.0
k ₁		2.8	2.8	2.8	3.5	4.0
L ⁴⁾		47	56	67	73	86
L ₁ ⁴⁾		93	109	125.5	138	164
L ₂		77.5	92	107.5	119	140.5
L ₃ ⁴⁾		102	119	133	150	177
l ₁ ⁴⁾		27.5	29	33	37	45
l ₂		25	27	29	36	44

Bores [mm]		Size					
		01	0	1	2	3	
EAS®-side	d ^{2) 3)}	d _{min}	10	15	22	32	35
		d _{max}	20	25	35	45	55
	d _p	d _{p min}	12	15	22	28	32
		d _{p max}	20	25	30	40	50
Steel bellows-side	d ₁ ^{2) 3)}	d _{1 min}	9	12	15	22	32
		d _{1 max}	20	25	35	42	50
	d ₂	d _{2 min}	9	12	15	22	32
		d _{2 max}	20 ⁵⁾	25 ⁶⁾	35 ⁷⁾	42 ⁸⁾	50
	d ₃	d _{3 min}	12	15	25	30	35
		d _{3 max}	25	32	42	45	55

We reserve the right to make dimensional and constructional alterations.

- 1) Further sizes for smaller and larger torques available on request
- 2) Shaft tolerance up to Ø 38_{h6} over Ø 38_{h6}
- 3) Transmittable torques available with smaller bores on request
- 4) Dimensions in intensioned condition (shorter in tensioned condition)
- 5) Up to Ø 18 keyway acc. DIN 6885/1, over Ø 18 keyway acc. DIN 6885/3
- 6) Up to Ø 22 keyway acc. DIN 6885/1, over Ø 22 keyway acc. DIN 6885/3
- 7) Up to Ø 33 keyway acc. DIN 6885/1, over Ø 33 keyway acc. DIN 6885/3
- 8) Up to Ø 38 keyway acc. DIN 6885/1, over Ø 38 keyway acc. DIN 6885/3

EAS®-Compact® ratchetting clutch/synchronous clutch

EAS®-Compact® torsionally rigid

Type 496. _ _ _ .0

EAS®-side cone bushing,
ROBA®-DS-side shrink disk hub
Type 496. _1_ .0, Sizes 01 to 4

Sizes 01 to 4

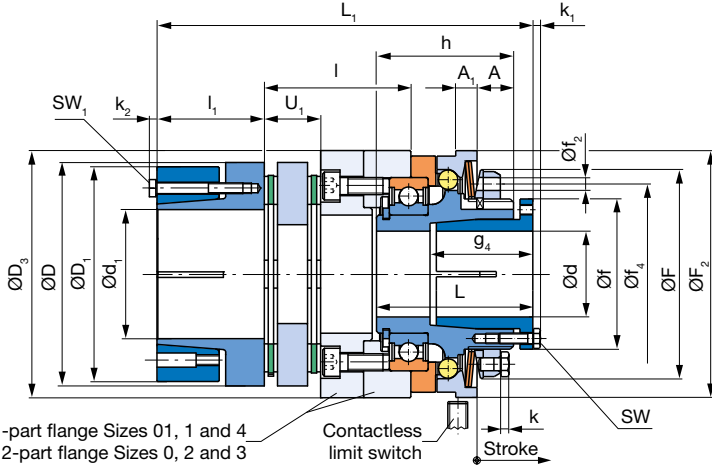

All EAS®-Compact® clutches can be combined with almost all components of the ROBA®-DS backlash-free shaft coupling. The Types shown here represent only a selection of the most established designs.

For further combination possibilities, see page 43.

We are happy to advise you on the dimensioning and configuration of your optimum clutch.

EAS®-side key hub,
ROBA®-DS-side clamping hub with keyway Type 496. _2_ .0, Sizes 01 and 0

EAS®-side key hub,
ROBA®-DS-side key hub Type 496. _2_ .0, Sizes 1 to 4

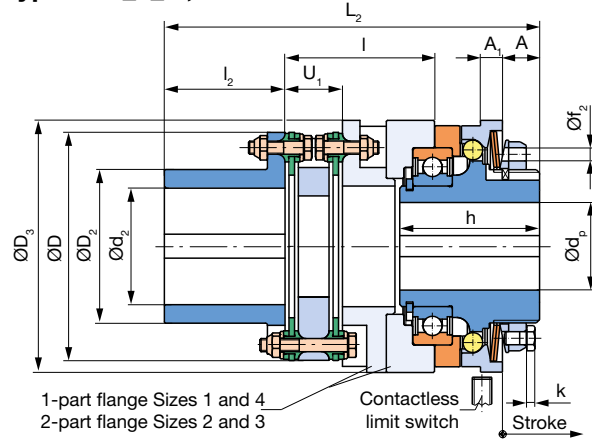
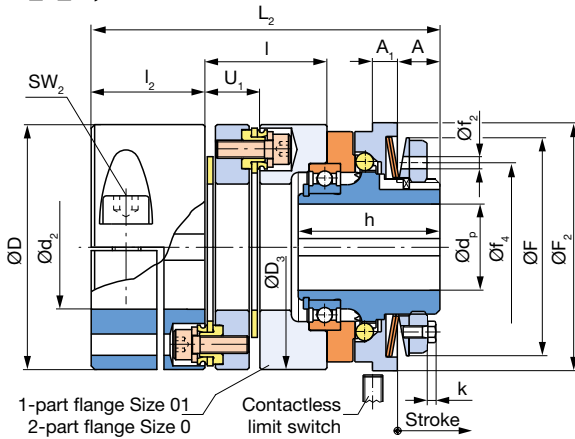

The missing dimensions ($\text{Ø}f_4$, $\text{Ø}F$ and $\text{Ø}F_2$) are identical to Type 496. _2_ .0

Order Number

EAS®-side	ROBA®-DS-side						
Cone bushing	Shrink disk hub	1	0	Ratchetting clutch ³⁾	Torque adjustment value (Optional)	With limit switch see pages 51 – 53 (Option)	
Key hub	Clamping hub ⁴⁾ with keyway (Sizes 01 – 0) / key hub (Sizes 1 – 4)	2	5	Synchronous clutch			

__ / 4 9 6 . __ . 0 / __ / __ / __ / __ / __

Sizes	Torque range ¹⁾		Hub 1 bore	Hub 2 bore	Radial torque adjustment
01	medium	5	$\text{Ø } d^{H7}$	$\text{Ø } d_1^{H7}$	see page 42 (Option)
to	high	6	$\text{Ø } d_p^{H7}$	$\text{Ø } d_2^{H7}$	
4	very high	7			
	maximum ²⁾	8			

Example: Order number 1 / 496.625.0 / 22 / 25 / 60 / limit switch 055.002.5 / radial adjustment

1) See Technical Data, limit torque for overload M_G
 2) Max. torque range only available as synchronous clutch, speed < 250 rpm
 3) Standard ratchetting division is 15°; other ratchetting divisions optionally available (45°/60°/90°/120°/180°/...)
 4) Clamping hub also available without keyway (Sizes 01-0)

EAS®-Compact® ratchetting clutch/synchronous clutch

Technical Data				Size ¹⁾					
				01	0	1	2	3	4
Limit torques for overload ¹⁾	Type 496.5_..0	M _G	[Nm]	5 – 12.5	10 – 25	20 – 50	40 – 100	70 – 175	120 – 300
	Type 496.6_..0	M _G	[Nm]	10 – 25	20 – 50	40 – 100	80 – 200	140 – 350	240 – 600
	Type 496.7_..0	M _G	[Nm]	20 – 50	40 – 100	80 – 200	160 – 400	280 – 700	480 – 1200
	Type 496.8_5.0 ⁵⁾	M _G	[Nm]	25 – 62.5	50 – 125	100 – 250	200 – 500	350 – 875	600 – 1500
Max. speed	n _{max}	[rpm]	4000	3000	2500	2000	1200	800	
Thrust washer stroke on overload		[mm]	1.2	1.5	1.8	2.0	2.2	2.5	
Nominal torques, torsionally rigid coupling	T _{KN}	[Nm]	100	150	300	650	1100	1600	
Permitted misalignments	axial ⁶⁾	ΔK _a	[mm]	0.9	1.1	0.8	1.1	1.3	1.5
	radial	ΔK _r	[mm]	0.20	0.20	0.20	0.25	0.30	0.30
	angular	ΔK _w	[°]	2.0	2.0	1.4	1.4	1.4	1.4

Mass moments of inertia and weights				Size					
				01	0	1	2	3	4
EAS®-hub-side	Type 496_1_0	I	[10 ⁻³ kgm ²]	0.211	0.531	1.388	2.846	6.858	29.432
	Type 496_2_0	I	[10 ⁻³ kgm ²]	0.205	0.505	1.302	2.630	6.359	28.443
ROBA®-DS-side	Type 496_1_0	I	[10 ⁻³ kgm ²]	0.849	2.395	2.915	9.543	21.443	38.996
	Type 496_2_0	I	[10 ⁻³ kgm ²]	0.709	2.086	2.417	7.815	18.215	31.480
Weights	Type 496_1_0	m	[kg]	1.63	2.95	3.80	7.04	11.45	19.16
	Type 496_2_0	m	[kg]	1.43	2.61	3.50	6.35	10.81	17.31

Tensioning screws				Size					
				01	0	1	2	3	4
In cone bushing EAS®-side	Number, dimensions	M	[mm]	6 x M4	6 x M4	8 x M4	8 x M5	8 x M6	8 x M8
	Wrench opening	SW	[mm]	7	7	7	8	10	13
	Tightening torque	T _A	[Nm]	4	4	4	8	12	25
In shrink disk ROBA®-DS-side	Number, dimensions	M ₁	[mm]	4 x M5	6 x M5	6 x M5	6 x M5	6 x M6	6 x M8
	Wrench opening	SW ₁	[mm]	8	8	8	8	10	13
	Tightening torque	T _A	[Nm]	6	6	6	8.5	10	25
In clamping hub ROBA®-DS-side	Number, dimensions	M ₂	[mm]	1 x M8	1 x M8	-	-	-	-
	Wrench opening	SW ₂	[mm]	6	6	-	-	-	-
	Tightening torque	T _A	[Nm]	33	33	-	-	-	-

Dimensions [mm]	Size					
	01	0	1	2	3	4
A	12	13.5	16	17	20.5	46
A ₁	7	8	9	10	12	16
D	69	79	77	104	123	143
D ₁	68	78	77	100	115	143
D ₂	-	-	50	70	80	100
D ₃	69	85	100	115	135	172
F	61.5	67	82	97	117	150
F ₂	70	85	100	115	135	166
f	38	44	56	70	84	100
f ₂	5	5	5	6	7	-
f ₄	50	55	70	84	100	-
Min. shaft length g ₄	34	39	42	48	53	93
h	40	48	59	64	75	115
k	2.8	2.8	3.5	4.0	4.0	-
k ₁	2.8	2.8	2.8	3.5	4.0	5.3
k ₂	3.5	3.5	3.5	3.5	4.0	5.3
L ⁴⁾	47	56	67	73	86	130
L ₁ ⁴⁾	105.3	132.8	141.2	175.2	208	237
L ₂	98.3	120.3	133.2	171.2	207	237
l	34.3	49.8	48.2	68.2	85	68
l ₁	32	37.5	40	50	55	60
l ₂	32	33.5	40	55	65	75
U ₁	15.3	15.8	21.2	26.2	34	35.2

Bores [mm]		Size						
		01	0	1	2	3	4	
EAS®-side	d ²⁾	d _{min}	10	15	22	32	35	40
		d _{max}	20	25	35	45	55	65
	d _p	d _{p min}	12	15	22	28	32	40
		d _{p max}	20	25	30	40	50	65
ROBA®-DS-side	d ₁ ³⁾	d _{1 min}	19	25	25	40	45	55
		d _{1 max}	38	45	45	60	70	90
	d ₂	d _{2 min}	19	25	16	25	30	35
		d _{2 max}	35	42	32	50	55	70

We reserve the right to make dimensional and constructional alterations.

- 1) Further sizes for smaller and larger torques available on request
- 2) Shaft tolerance up to Ø 38_{h6/g6} over Ø 38_{h8}
- 3) Recommended shaft tolerance g₆
- 4) Dimensions in untensioned condition (shorter in tensioned condition)
- 5) Maximum speed: 250 rpm
- 6) Only permitted as a static or virtually static value.

EAS[®]-Compact[®] ratchetting clutch/synchronous clutch

EAS[®]-Compact[®] lastic backlash-free

Type 494. _ _ _ _
Sizes 01 to 4

EAS[®]-side cone bushing,
ROBA[®]-ES-side clamping hub
Type 494. _ 0 _ _

EAS[®]-side cone bushing,
ROBA[®]-ES-side shrink disk hub
Type 494. _ 1 _ _

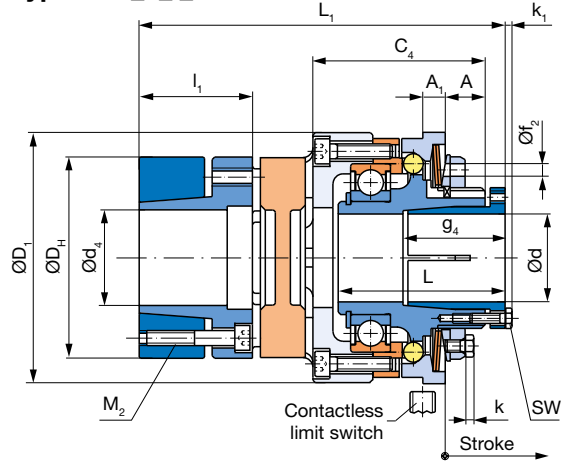
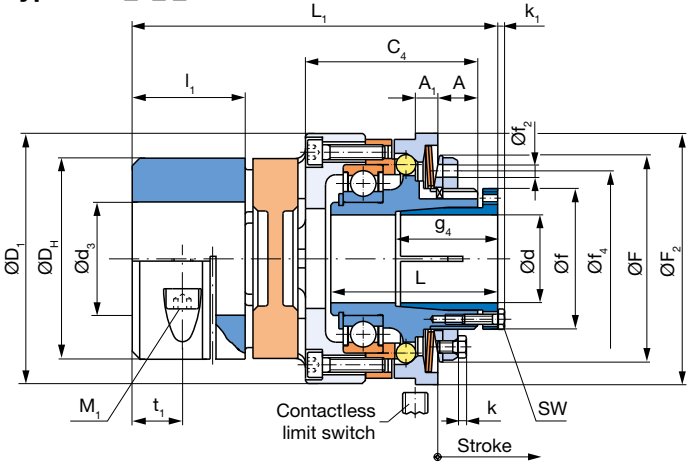

The missing dimensions (Øf, Øf₄, ØF and ØF₂) are identical to Type 494. _ 0 _ _

EAS[®]-side key hub,
ROBA[®]-ES-side key hub
Type 494. _ 2 _ _

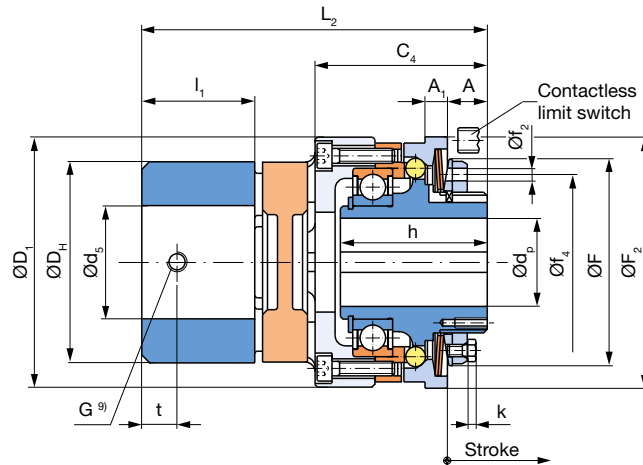

Order Number

EAS[®]-side	ROBA[®]-ES-side								
Cone bushing	Clamping hub	0							
Cone bushing	Shrink disk hub	1	0	Ratchetting clutch ²⁾		Torque adjustment value (Optional)			With limit switch see pages 51 – 53 (Option)
Key hub	Key hub	2	5	Synchronous clutch					



Sizes	Torque range ¹⁾		Flexible coupling		Hub 1 bore	Hub 2 bore	Radial torque adjustment
01	medium	5	92 Shore A	3	Ø d ^{H7}	Ø d ₃ ^{F7}	see page 42 (Option)
to	high	6	98 Shore A	4	Ø d _p ^{H7}	Ø d ₄ ^{H7}	
4	very high	7	64 Shore D	6		Ø d ₅ ^{H7}	

Example: Order number 1 / 494.615.3 / 22 / 25 / 60 / limit switch 055.002.5 / radial adjustment

- 1) See Technical Data, limit torque for overload M_G
- 2) Standard ratchetting division is 15°; other ratchetting divisions optionally available (45°/60°/90°/120°/180°/...)
- 3) The transmittable torques on the flexible coupling "T_{KN}" are dependent on factors such as temperature, torsional rigidity, etc., see also coupling dimensioning ROBA[®]-ES catalogue K.940.V_ _ or contact the manufacturer. Furthermore, the transmittable torques of the flexible coupling are dependent on the bore diameter d₃ or d₄, see also Table 1 on page 50.
- 4) Shaft tolerance up to Ø 38_{h6}, over Ø 38_{h8}
- 5) Transmittable torques available with smaller bores on request
- 6) Smaller bores for smaller torques available on request
- 7) Larger bores available on request
- 8) Shaft tolerance up to Ø 40_{h6}
- 9) Keyway 180° offset to "G"
- 10) Dimensions in untensioned condition (shorter in tensioned condition)

EAS®-Compact® ratchetting clutch/synchronous clutch

Technical Data				Size						
				01	0	1	2	3	4	
Limit torques for overload ³⁾	Type 494.5 _ _ _	M_G	[Nm]	5 – 12.5	10 – 25	20 – 50	40 – 100	70 – 175	120 – 300	
	Type 494.6 _ _ _	M_G	[Nm]	10 – 25	20 – 50	40 – 100	80 – 200	140 – 350	240 – 600	
	Type 494.7 _ _ _	M_G	[Nm]	20 – 50	40 – 100	80 – 200	160 – 400	280 – 700	480 – 1200	
Max. speed		n_{max}	[rpm]	4000	3000	2500	2000	1200	800	
Thrust washer stroke on overload			[mm]	1.2	1.5	1.8	2.0	2.2	2.5	
Nominal and maximum torques ³⁾ , flexible coupling	92 Shore A	T_{KN}/T_{max}	[Nm]	35 / 70	95 / 190	190 / 380	265 / 530	310 / 620	900 / 1800	
	98 Shore A	T_{KN}/T_{max}	[Nm]	60 / 120	160 / 320	325 / 650	450 / 900	525 / 1050	1040 / 2080	
	64 Shore D	T_{KN}/T_{max}	[Nm]	75 / 150	200 / 400	405 / 810	560 / 1120	655 / 1310	1250 / 2500	
Permitted misalignments	axial	ΔK_a	[mm]	1.4	1.5	1.8	2.0	2.1	2.6	
		92 Shore A	ΔK_r	[mm]	0.14	0.15	0.17	0.19	0.21	0.25
	radial	98 Shore A	ΔK_r	[mm]	0.10	0.11	0.12	0.14	0.16	0.18
		64 Shore D	ΔK_r	[mm]	0.07	0.08	0.09	0.10	0.11	0.13
	angular	92 Shore A	ΔK_w	[°]	1.0	1.0	1.0	1.0	1.0	1.0
		98 Shore A	ΔK_w	[°]	0.9	0.9	0.9	0.9	0.9	0.9
	64 Shore D	ΔK_w	[°]	0.8	0.8	0.8	0.8	0.8	0.8	

Mass moments of inertia and weights				Size					
				01	0	1	2	3	4
EAS®-hub-side	Type 494. 0 _ _	I	[10 ⁻³ kgm ²]	0.211	0.531	1.388	2.846	6.858	29.432
	Type 494. 1 _ _	I	[10 ⁻³ kgm ²]	0.211	0.531	1.388	2.846	6.858	29.432
	Type 494. 2 _ _	I	[10 ⁻³ kgm ²]	0.205	0.505	1.302	2.630	6.359	28.443
ROBA®-ES-side	Type 494. 0 _ _	I	[10 ⁻³ kgm ²]	0.322	0.700	1.846	7.627	14.530	48.570
	Type 494. 1 _ _	I	[10 ⁻³ kgm ²]	0.381	0.833	2.280	7.475	14.167	43.038
	Type 494. 2 _ _	I	[10 ⁻³ kgm ²]	0.324	0.696	1.847	7.613	14.520	49.106
Weights	Type 494. 0 _ _	m	[kg]	1.06	1.58	2.69	6.31	9.23	21.53
	Type 494. 1 _ _	m	[kg]	1.18	1.74	3.05	6.20	8.91	21.44
	Type 494. 2 _ _	m	[kg]	1.02	2.09	2.70	6.23	9.56	21.09

Tensioning screws				Size					
				01	0	1	2	3	4
In cone bushing EAS®-side	Number, dimensions	M	[mm]	6 x M4	6 x M4	8 x M4	8 x M5	8 x M6	8 x M8
	Wrench opening	SW	[mm]	7	7	7	8	10	13
	Tightening torque	T_A	[Nm]	4	4	4	8	12	25
In clamping hub ROBA®-ES-side	Number, dimensions	M_1	[mm]	1 x M6	1 x M8	1 x M8	1 x M10	1 x M12	1 x M14
	Wrench opening	SW ₁	[mm]	5	6	6	8	10	12
	Tightening torque	T_A	[Nm]	10.5	25	25	70	120	200
In shrink disk ROBA®-ES-side	Number, dimensions	M_2	[mm]	4 x M5	8 x M5	8 x M6	4 x M8	4 x M8	4 x M12
	Wrench opening	SW ₂	[mm]	4	4	5	6	6	10
	Tightening torque	T_A	[Nm]	6	6	10.5	25	30	90

Dimensions [mm]	Size					
	01	0	1	2	3	4
A	12	13.5	16	17	20.5	46
A ₁	7	8	9	10	12	16
C ₄	47	56.5	69	74	87	130
D ₁	70	85	100	115	135	175
D _H	55	65	80	95	105	135
F	61.5	67	82	97	117	150
F ₂	70	85	100	115	135	166
f	38	44	56	70	84	100
f ₂	5	5	5	6	7	-
f ₄	50	55	70	84	100	-
G ⁹⁾	M5	M6	M8	M8	M8	M10
Min. shaft length g ₄	34	39	42	48	53	93
h	40	48	59	64	75	115
k	2.8	2.8	3.5	4.0	4.0	-
k ₁	2.8	2.8	2.8	3.5	4.0	5.3
L ¹⁰⁾	47	56	67	73	86	130
L ₁ ¹⁰⁾	102	119.5	146	159	182	255
L ₂	95	111.5	138	150	171	240
l ₁	30	35	45	50	56	75
t	10	15	15	20	25	20
t ₁	12	13.5	20	20	21	27.5

Bores [mm]		Size						
		01	0	1	2	3	4	
EAS®-side	d ^{4) 5)}	d _{min}	10	15	22	32	35	40
		d _{max}	20	25	35	45	55	65
	d _P ^{6) 7)}	d _{P min}	12	15	22	28	32	40
		d _{P max}	20	25	30	40	50	65
ROBA®-ES-side	d ₃ ³⁾	d _{3 min}	15	19	20	28	35	45
		d _{3 max}	28	35	45	50	55	80
	d ₄ ³⁾	d _{4 min}	15	19	20	28	35 ⁸⁾	45
		d _{4 max}	28	38	45	50	60 ⁸⁾	75
	d ₅ ³⁾	d _{5 min}	8	10	12	14	20	38
		d _{5 max}	28	38	45	55	60	80

We reserve the right to make dimensional and constructional alterations.

EAS[®]-NC ratchetting clutch/synchronous clutch

EAS[®]-NC short hub

Type 450.____.0
Sizes 03 and 02

with cone bushing
Type 450._1_.0

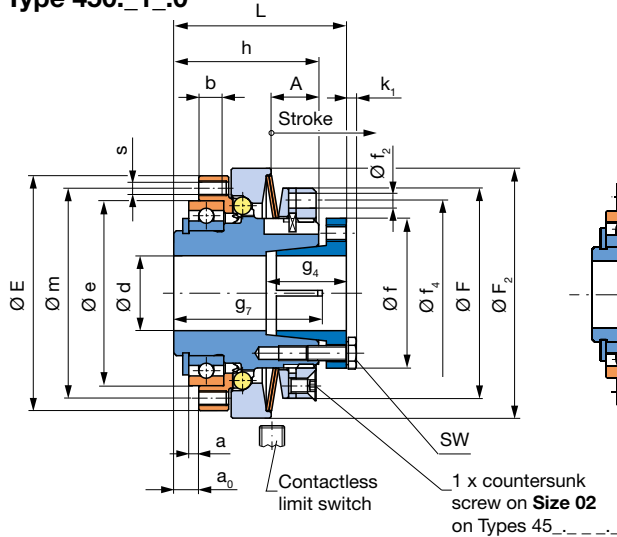

with keyway
Type 450._2_.0

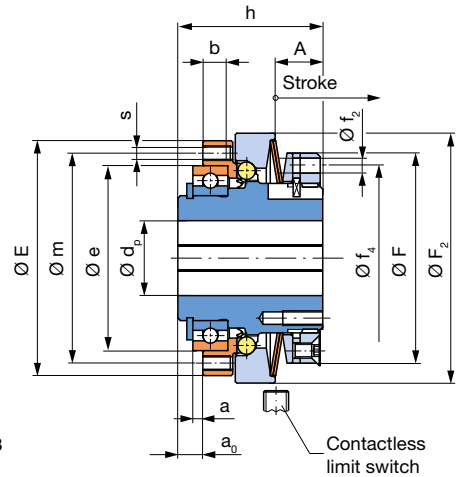

EAS[®]-NC long protruding hub

Type 450.____.1
Sizes 03 and 02

with cone bushing
Type 450._1_.1

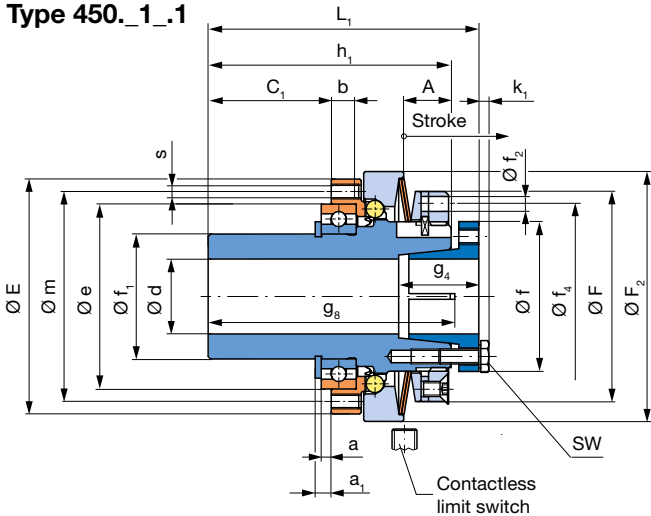

with keyway
Type 450._2_.1

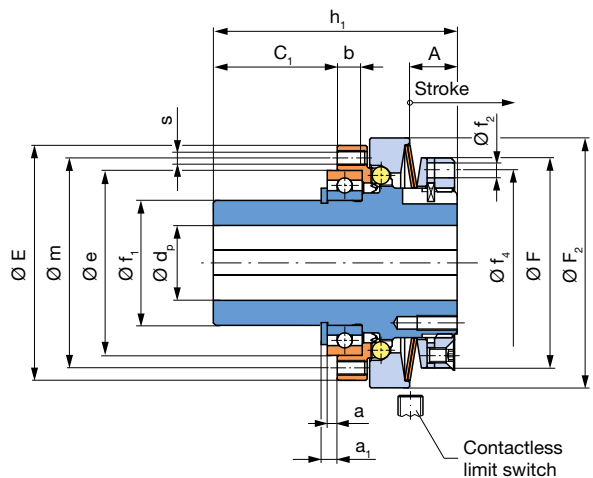

Order Number

	with cone bushing	1	0	Ratchetting clutch	Torque adjustment value (Optional)
	with keyway	2	5	Synchronous clutch	
▼					
__	/	4	5	0	. __ __ . __ / __ / __ / __
▲					
Sizes 03 and 02	Torque range ¹⁾ medium high very high	5 6 7	short hub long protruding hub	0 1	Hub bore Ø d ^{H7} Ø d _p ^{H7}
					With limit switch see pages 51 – 53 (Option)

Example: Order number 02 / 450.610.0 / 15 / 8 / limit switch 055.002.5

1) See Technical Data, limit torque for overload M_G

EAS®-NC ratchetting clutch/synchronous clutch

Technical Data				Size ¹⁾	
				03	02
Limit torques for overload ¹⁾	Type 450.5_ _ _	M _G	[Nm]	0.65 – 1.30	2 – 5
	Type 450.6_ _ _	M _G	[Nm]	1.30 – 2.60	5 – 10
	Type 450.7_ _ _	M _G	[Nm]	2.00 – 3.80	6 – 15
Max. speed		n _{max}	[rpm]	4000	4000
Thrust washer stroke on overload			[mm]	0.8	1.0

Mass moments of inertia and weights				Size	
				03	02
Hub-side	Type 450._1_0	I	[10 ⁻³ kgm ²]	0.027	0.054
	Type 450._2_0	I	[10 ⁻³ kgm ²]	0.025	0.051
	Type 450._1_1	I	[10 ⁻³ kgm ²]	0.028	0.058
	Type 450._2_1	I	[10 ⁻³ kgm ²]	0.026	0.055
Pressure flange-side	Type 450. _ _ _ _	I	[10 ⁻³ kgm ²]	0.008	0.018
Weights	Type 450._1_0	m	[kg]	0.18	0.28
	Type 450._2_0	m	[kg]	0.17	0.26
	Type 450._1_1	m	[kg]	0.20	0.32
	Type 450._2_1	m	[kg]	0.19	0.30

Tensioning screws and screw-on bores				Size	
				03	02
Tensioning screws in cone bushing	Number, dimensions	M	[mm]	4 x M3	4 x M3
	Wrench opening	SW	[mm]	5.5	5.5
	Tightening torque	T _A	[Nm]	1	1
Screw-on bores in pressure flange	Number, dimensions	s	[mm]	6 x M3	6 x M3

Dimensions [mm]	Size		
	03	02	
A	7.2	9.5	
a ²⁾	2	2	
a ₀	4.5	5.0	
a ₁	3.0	3.2	
b	5	5	
C ₁	20.5	25	
E	40	47	
e _{h5} ⁴⁾	30	37	
F	37	42	
F ₂	45	50	
f	26	30	
f _{1 h6}	17	25	
f ₂	-	3	
f ₄	-	37	
Minimum shaft length	g ₄	11.5	15.5
	g ₇	25.5	30.5
	g ₈	41.5	50.5
h	24	29	
h ₁	40	49	
k ₁	2	2	
L ⁶⁾	28.5	34.5	
L ₁ ⁶⁾	44.5	54.5	
m	35	42	

Bores [mm]		Size	
		03	02
d	d _{min}	6	8
	d _{max}	12	15
d _p ³⁾	d _{p min}	6	8
	d _{p max}	11	16 ⁵⁾

We reserve the right to make dimensional and constructional alterations.

- 1) Further sizes for smaller and larger torques available on request
- 2) Mounting tolerance + 0.1
- 3) The position of the keyway to the mounting bore "s" in the pressure flange is not defined. Defined position available on request
- 4) Tolerance user-side H7
- 5) Up to Ø 14 keyway acc. DIN 6885/1, over Ø 14 keyway acc. DIN 6885/3
- 6) Dimensions in untensioned condition (shorter in tensioned condition)

EAS[®]-NC ratchetting clutch/synchronous clutch

EAS[®]-NC double bearing design with cone bushing

Type 450._1_.2
Sizes 03 and 02

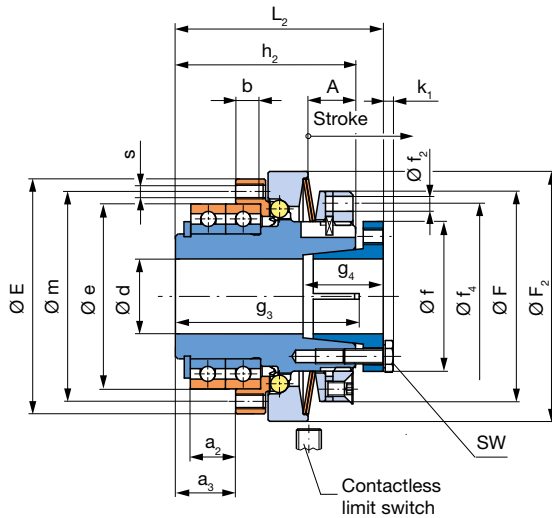

EAS[®]-NC double bearing design with keyway

Type 450._2_.2
Sizes 03 and 02

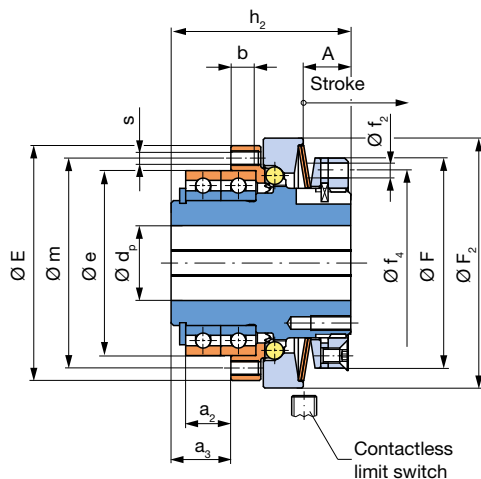

Order Number

	with cone bushing with keyway	1 2	0 5	Ratchetting clutch Synchronous clutch	Torque adjustment value (Optional)
		▽	▽		▽
	__ / 4 5 0 . __			2 / __ / __ / __	
▲		▲		▲	▲
Sizes 03 and 02	Torque range ¹⁾ medium high very high	5 6 7	2-bearing design	2	Hub bore Ø d ^{H7} Ø d _p ^{H7}
					With limit switch see pages 51 – 53 (Option)

Example: Order number 02 / 450.610.2 / 15 / 8 / limit switch 055.002.5

EAS[®]-NC ratchetting clutch/synchronous clutch

Technical Data				Size ¹⁾	
				03	02
Limit torques for overload ¹⁾	Type 450.5_..2	M _G	[Nm]	0.65 – 1.30	2 – 5
	Type 450.6_..2	M _G	[Nm]	1.30 – 2.60	5 – 10
	Type 450.7_..2	M _G	[Nm]	2.00 – 3.80	6 – 15
Max. speed		n _{max}	[rpm]	4000	4000
Thrust washer stroke on overload			[mm]	0.8	1.0

Mass moments of inertia and weights				Size	
				03	02
Hub-side	Type 450._1_..2	I	[10 ⁻³ kgm ²]	0.028	0.058
	Type 450._2_..2	I	[10 ⁻³ kgm ²]	0.026	0.055
Pressure flange-side	Type 450.2	I	[10 ⁻³ kgm ²]	0.008	0.018
Weights	Type 450._1_..2	m	[kg]	0.13	0.31
	Type 450._2_..2	m	[kg]	0.18	0.29

Tensioning screws and screw-on bores				Size	
				03	02
Tensioning screws in cone bushing	Number, dimensions	M	[mm]	4 x M3	4 x M3
	Wrench opening	SW	[mm]	5.5	5.5
	Tightening torque	T _A	[Nm]	1	1
Screw-on bores in pressure flange	Number, dimensions	s	[mm]	6 x M3	6 x M3

Dimensions [mm]	Size		
	03	02	
A	7.2	9.5	
a ₂ ²⁾	9	9	
a ₃	11.5	12	
b	5	5	
E	40	47	
e _{h5} ⁴⁾	30	37	
F	37	42	
F ₂	45	50	
f	26	30	
f ₂	-	3	
f ₄	-	37	
Minimum shaft length	g ₃	32.5	37.5
	g ₄	11.5	15.5
h ₂	31	36	
k ₁	2	2	
L ₂ ⁶⁾	35.5	41.5	
m	35	42	

Bores [mm]		Size	
		03	02
d	d _{min}	6	8
	d _{max}	12	15
d _p ³⁾	d _{p min}	6	8
	d _{p max}	11	16 ⁵⁾

We reserve the right to make dimensional and constructional alterations.

- 1) Further sizes for smaller and larger torques available on request
- 2) Mounting tolerance + 0.1
- 3) The position of the keyway to the mounting bore "s" in the pressure flange is not defined. Defined position available on request
- 4) Tolerance user-side H7
- 5) Up to Ø 14 keyway acc. DIN 6885/1, over Ø 14 keyway acc. DIN 6885/3
- 6) Dimensions in untensioned condition (shorter in tensioned condition)

EAS[®]-NC ratchetting clutch/synchronous clutch

EAS[®]-NC with steel bellows coupling

Type 453.____.0
Sizes 03 and 02

EAS[®]-side cone bushing,
Steel bellows-side cone bushing
Type 453.1_0

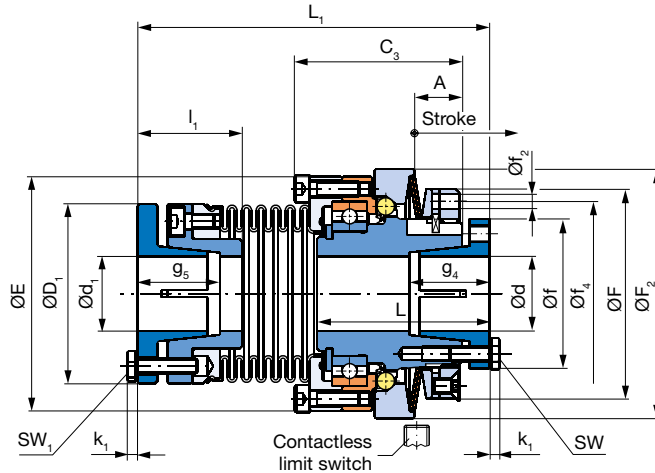

EAS[®]-side key hub,
Steel bellows-side key hub
Type 453.2_0

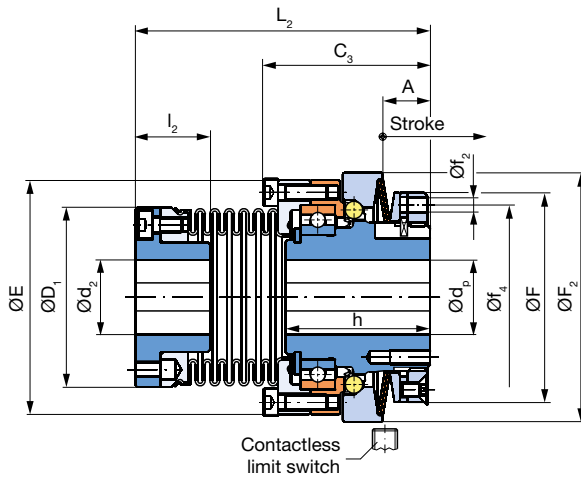

Order Number

EAS[®]-side Cone bushing Key hub	Steel bellows-side Cone bushing Key hub	1 2	0 5	Ratchetting clutch Synchronous clutch	Torque adjustment value (Optional)
--	--	----------------------	----------------------	--	---------------------------------------

___ / 4 5 3 . ___ ___ . 0 / ___ / ___ / ___ / ___

Sizes 03 and 02	Torque range ¹⁾ medium high very high	5 6 7	Hub 1 bore Ø d ^{H7} Ø d _p ^{H7}	Hub 2 bore Ø d ₁ ^{H7} Ø d ₂ ^{H7}	With limit switch see pages 51 – 53 (Option)
---------------------------------	--	----------------------------------	---	--	--

Example: Order number 02 / 453.615.0 / 15 / 15 / 8 / limit switch 055.002.5

1) See Technical Data, limit torque for overload M_G

EAS®-NC ratchetting clutch/synchronous clutch

Technical Data				Size ¹⁾	
				03	02
Limit torques for overload ¹⁾	Type 453.5_ _0	M_G	[Nm]	0.65 – 1.30	2 – 5
	Type 453.6_ _0	M_G	[Nm]	1.30 – 2.60	5 – 10
	Type 453.7_ _0	M_G	[Nm]	2.00 – 3.80	6 – 15
Max. speed		n_{max}	[rpm]	4000	4000
Thrust washer stroke on overload			[mm]	0.8	1.0
Nominal torques, steel bellows coupling		T_{KN}	[Nm]	12	25
Permitted misalignments	axial	ΔK_a	[mm]	0.2	0.3
	radial	ΔK_r	[mm]	0.1	0.1
	angular	ΔK_w	[°]	2	2

Mass moments of inertia and weights				Size	
				03	02
Hub-side	Type 453.1_0	I	[10 ⁻³ kgm ²]	0.027	0.054
	Type 453.2_0	I	[10 ⁻³ kgm ²]	0.025	0.051
Steel bellows-side	Type 453.1_0	I	[10 ⁻³ kgm ²]	0.027	0.063
	Type 453.2_0	I	[10 ⁻³ kgm ²]	0.025	0.057
Weights	Type 453.1_0	m	[kg]	0.27	0.45
	Type 453.2_0	m	[kg]	0.24	0.39

Tensioning screws				Size	
				03	02
In cone bushing EAS®-side	Number, dimensions	M	[mm]	4 x M3	4 x M3
	Wrench opening	SW	[mm]	5.5	5.5
	Tightening torque	T_A	[Nm]	1.3	1.3
In cone bushing steel bellows-side	Number, dimensions	M_1	[mm]	4 x M3	4 x M3
	Wrench opening	SW_1	[mm]	5.5	5.5
	Tightening torque	T_A	[Nm]	1.3	1.3

Dimensions [mm]	Size		
	03	02	
A	7.2	9.5	
C_3	28	33.5	
D_1	30	36	
E	40	47	
F	37	42	
F_2	45	50	
f	26	30	
f_2	-	3	
f_4	-	37	
Minimum shaft length	g_4	11.5	15.5
	g_5	12.5	16
h	24	29	
k_1	2	2	
$L^{3)}$	28.5	34.5	
$L_1^{3)}$	58.5	70.5	
L_2	49.3	59	
$l_1^{3)}$	14	21	
l_2	9.5	15	

Bores [mm]		Size		
		03	02	
EAS®-side	d	d_{min}	6	8
		d_{max}	12	15
	d_p	$d_{p min}$	6	8
		$d_{p max}$	11	16 ²⁾
Steel bellows-side	d_1	$d_{1 min}$	6	8
		$d_{1 max}$	12	15
	d_2	$d_{2 min}$	6	8
		$d_{2 max}$	11	16 ²⁾

We reserve the right to make dimensional and constructional alterations.

- 1) Further sizes for smaller and larger torques available on request
- 2) Up to \varnothing 14 keyway acc. DIN 6885/1, over \varnothing 14 keyway acc. DIN 6885/3
- 3) Dimensions in untensioned condition (shorter in tensioned condition)

EAS[®]-Compact[®] overload clutch

Function

If the set limit torque is exceeded, the clutch disengages. The torque drops immediately. A mounted limit switch registers the disengagement movement and switches off the drive. The limit switch signal can also be used for further control functions.

EAS[®]-Compact[®] overload clutches separate the input and the output side completely and remain in this state until they are intentionally re-engaged by hand or via a suitable device.

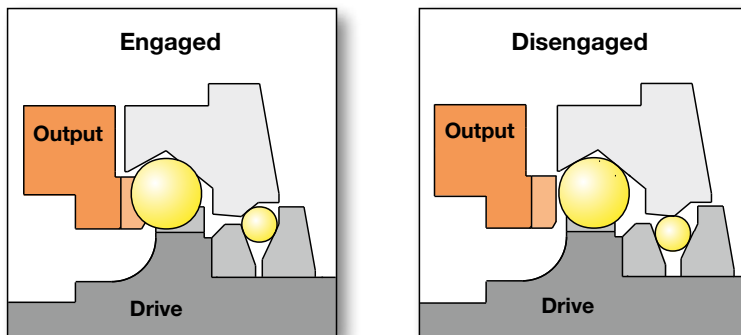
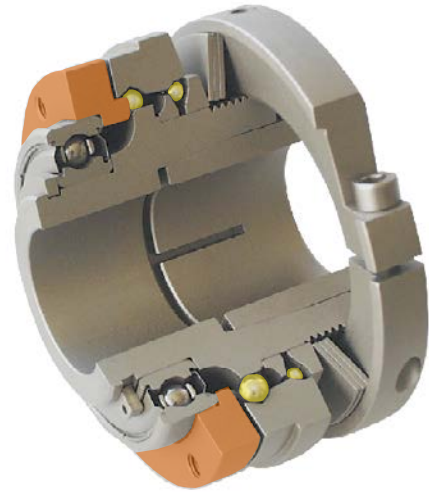

When in operation, the EAS[®]-Compact[®] overload clutches transmit the torque backlash-free. On overload occurrence, they ensure free run-out of the drive components.



The EAS[®]-Compact[®] overload clutches
Types 49_.5_4._, 49_.6_4._ and 49_.7_4._
are also available in ATEX design according
to directive 94/9 EC (ATEX 95).

Summary of constructional designs EAS®-Compact® overload clutch

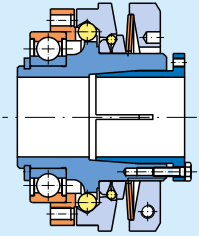
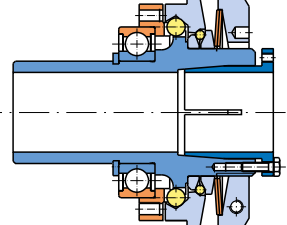
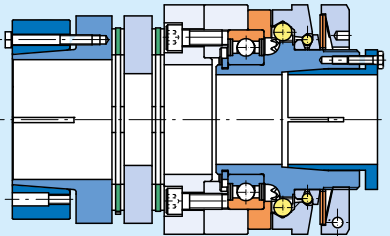
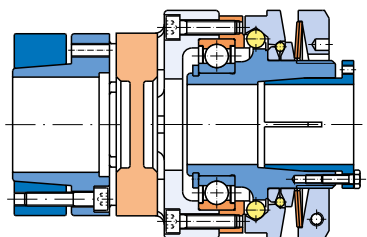
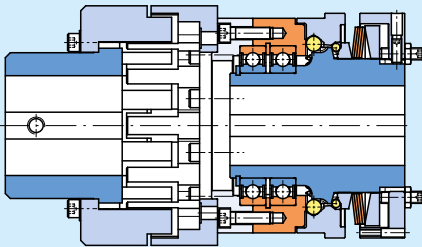
<p>EAS®-Compact® overload short hub</p> 	<p>Torque: 5 to 3000 Nm</p> <p>Sizes 01 to 3 Type 490._ _ 4.0</p> <p>Sizes 4 and 5 as 2-bearing design Type 490._ _ 4.2</p>	<ul style="list-style-type: none"> Flange clutch for direct installation of drive elements with the resulting radial force approximately in the bearing centre <p>With cone bushing Type 490._14._ With key hub Type 490._24._</p> <p style="text-align: right;">Page 28</p>
<p>EAS®-Compact® overload long protruding hub</p> 	<p>Torque: 5 to 1000 Nm</p> <p>Sizes 01 to 3 Type 490._ _ 4.1</p>	<ul style="list-style-type: none"> Flange clutch for very wide drive elements or elements with a very small diameter Suitable bearings for the drive element are ball bearings, needle bearings or plain bearings. <p>With cone bushing Type 490._14.1 With key hub Type 490._24.1</p> <p style="text-align: right;">Page 30</p>
<p>EAS®-Compact® overload torsionally rigid</p> 	<p>Torque: 5 to 3000 Nm</p> <p>Sizes 01 to 3 Type 496._ _ 4.0</p> <p>Sizes 4 and 5 as 2-bearing design Type 496._ _ 4.2</p>	<ul style="list-style-type: none"> Double shaft design with a robust disk pack coupling Compensation for axial, radial and angular shaft misalignments High torsional rigidity <p>Hub designs: <u>EAS®-side/torsionally rigid side</u> Cone bushing/shrink disk hub Type 496._14._ Key hub/clamping hub Type 496._24.0 Key hub/key hub Type 496._24._</p> <p style="text-align: right;">Page 32</p>
<p>EAS®-Compact® overload lastic backlash-free</p> 	<p>Torque: 5 to 1500 Nm</p> <p>Sizes 01 to 3 Type 494._ _ 4._</p> <p>Size 4 as 2-bearing design Type 494._ _ 4._</p>	<ul style="list-style-type: none"> Double shaft design with a flexible, backlash-free coupling Compensation for axial, radial and angular shaft misalignments High damping characteristics <p>Hub designs: <u>EAS®-side/flexible side</u> Cone bushing/clamping hub Type 494._04._ Cone bushing/shrink disk hub Type 494._14._ Key hub/key hub Type 494._24._</p> <p style="text-align: right;">Page 36</p>
<p>EAS®-Compact® overload lastic</p> 	<p>Torque: 240 to 3000 Nm</p> <p>Size 5 as 2-bearing design Type 494._ _ 4.2</p>	<ul style="list-style-type: none"> Double shaft design with a flexible coupling Compensation for axial, radial and angular shaft misalignments <p>Hub designs: <u>EAS®-side/flexible side</u> Key hub/key hub Type 494._24.2 Cone bushing/key hub Type 494._34.2</p> <p style="text-align: right;">Page 40</p>

EAS[®]-Compact[®] overload clutch

EAS[®]-Compact[®] overload short hub with cone bushing

**Type 490._14._
Sizes 01 to 5**

Type 490._14.0, Sizes 01 to 3

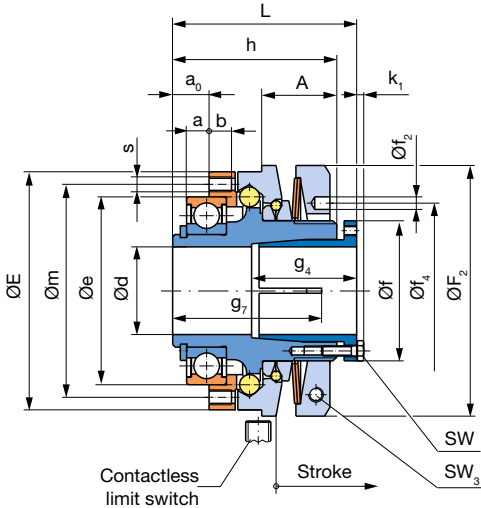

Type 490._14.2, Sizes 4 to 5

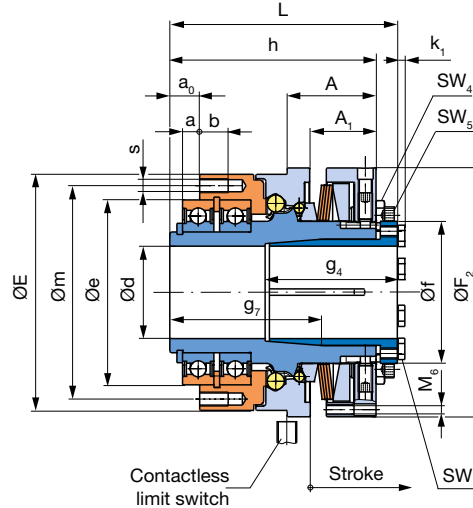

EAS[®]-Compact[®] overload short hub with keyway

**Type 490._24._
Sizes 01 to 5**

Type 490._24.0, Sizes 01 to 3

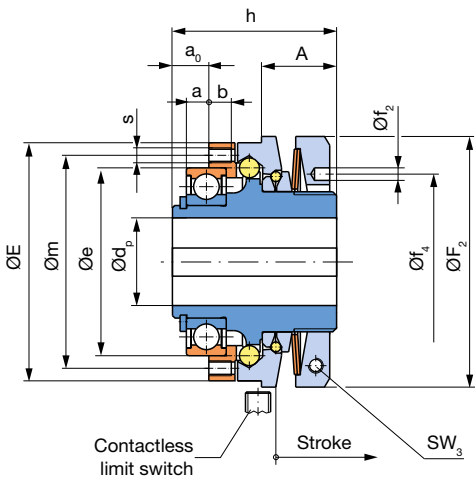

Type 490._24.2, Sizes 4 to 5

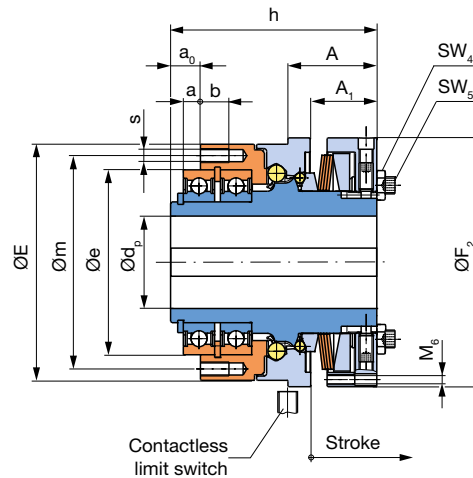

Order Number

		with cone bushing	1			Torque adjustment value (Optional)	
		with keyway	2	4	Overload clutch		
Sizes	Torque range ¹⁾						
01	medium	5	1-bearing design	0	Hub bore	With limit switch	
to	high	6	(Sizes 01-3)		Ø d ^{H7}	see page 51	
5	very high	7	2-bearing design	2	Ø d _p ^{H7}	(Option)	
	maximum	8	(Sizes 4-5)				

Example: Order number 1 / 490.614.0 / 25 / 60 / limit switch 055.002.5

1) See Technical Data, limit torque for overload M_G

EAS®-Compact® overload clutch

Technical Data				Size ¹⁾						
				01	0	1	2	3	4	5
Limit torques for overload ¹⁾	Type 490.5_4_	M _G	[Nm]	5–12.5	10–25	20–50	40–100	80–200	120–300	240–600
	Type 490.6_4_	M _G	[Nm]	10–25	20–50	40–100	80–200	160–400	240–600	480–1200
	Type 490.7_4_	M _G	[Nm]	20–50	40–100	80–200	160–400	320–800	480–1200	960–2400
	Type 490.8_4_	M _G	[Nm]	25–62.5	50–125	100–250	200–500	400–1000	600–1500	1200–3000
Max. speed	n _{max}	[rpm]	8000	7000	6000	5000	4000	3500	3000	
Thrust washer stroke on overload		[mm]	2.0	2.6	3.2	3.8	4.5	5.5	6.5	

Mass moments of inertia and weights				Size						
				01	0	1	2	3	4	5
Hub-side	Type 490_14_	I	[10 ⁻³ kgm ²]	0.383	0.943	2.279	4.421	10.396	39.730	120.834
	Type 490_24_	I	[10 ⁻³ kgm ²]	0.377	0.917	2.193	4.205	9.867	37.215	112.399
Pressure flange-side	Type 490_14_	I	[10 ⁻³ kgm ²]	0.093	0.234	0.643	1.306	2.649	19.950	65.760
	Type 490_24_	I	[10 ⁻³ kgm ²]	0.093	0.234	0.643	1.306	2.649	19.950	65.760
Weights	Type 490_14_	m	[kg]	0.92	1.55	2.58	3.70	5.83	17.10	34.70
	Type 490_24_	m	[kg]	0.87	1.43	2.35	3.37	5.31	16.50	34.30

Screws and screw-on bores				Size						
				01	0	1	2	3	4	5
Tensioning screws in cone bushing	Number, dimensions	M	[mm]	6 x M4	6 x M4	8 x M4	8 x M5	8 x M6	8 x M8	8 x M10
	Wrench opening	SW	[mm]	7	7	7	8	10	13	16
	Tightening torque	T _A	[Nm]	4	4	4	8	12	25	71
Locking screw in adjusting nut Sizes 01 - 3	Number, dimensions	M ₃	[mm]	1 x M4	1 x M4	1 x M5	1 x M5	1 x M6	-	-
	Wrench opening	SW ₃	[mm]	3	3	4	4	5	-	-
	Tightening torque	T _A	[Nm]	3	5	9	9	15	-	-
Pins/threads in adjusting nut Sizes 4 - 5	Wrench opening	SW ₄	[mm]	-	-	-	-	-	18	18
	Wrench opening	SW ₅	[mm]	-	-	-	-	-	6	6
	Number, dimensions	M ₆	[mm]	-	-	-	-	-	3 x M8	3 x M8
Screw-on bores in pressure flange	Number, dimensions	s	[mm]	8 x M4	8 x M5	8 x M6	8 x M6 *	8 x M8 *	8 x M10	8 x M12
	* Screws quality class 12.9 must be used to secure the drive element.									

Dimensions [mm]	Size							
	01	0	1	2	3	4	5	
A	24	28	30	34	40	62.5	80	
A ₁	-	-	-	-	-	46.5	60	
a ²⁾	5	7	9	10	10	12	13	
a ₀	8	11	14	16	18	21	23	
b	6	7	9	10	12	20	20	
E	65	80	95	110	130	166	215	
e _{h5} ³⁾	47	62	75	90	100	130	160	
F ₂	70	85	100	115	135	175	225	
f	38	44	56	70	84	100	134	
f ₂	5	5	5	6	7	-	-	
f ₄	50	55	70	84	100	-	-	
Minimum shaft length	g ₄	34	39	42	48	53	93	
	g ₇	36	43	54	57	69	110	
h	45	55	65	72	82	145	175	
k ₁	2.8	2.8	2.8	3.5	4.0	5.3	6.4	
L ⁴⁾	52	63	73	81	93	160	193	
m	56	71	85	100	116	150	185	

Bores [mm]		Size						
		01	0	1	2	3	4	5
d ^{5) 6)}	d _{min}	10	15	22	32	35	40	45
	d _{max}	20	25	35	45	55	65	85
d _p	d _{p min} ⁷⁾	12	15	22	28	32	40	45
	d _{p max} ⁸⁾	20	25	30	40	50	65	80

We reserve the right to make dimensional and constructional alterations.

- 1) Further sizes for smaller and larger torques available on request
- 2) Mounting tolerance + 0.1
- 3) Tolerance user-side H7
- 4) Dimensions in tensioned condition (shorter in tensioned condition)
- 5) Shaft tolerance up to Ø 38_{h6} over Ø 38_{h8}
- 6) Transmittable torques available with smaller bores on request
- 7) Smaller bores for low torques available on request
- 8) Larger bores available on request

EAS[®]-Compact[®] overload clutch

EAS[®]-Compact[®] overload
long protruding hub with cone bushing

Type 490._14.1
Sizes 01 to 3

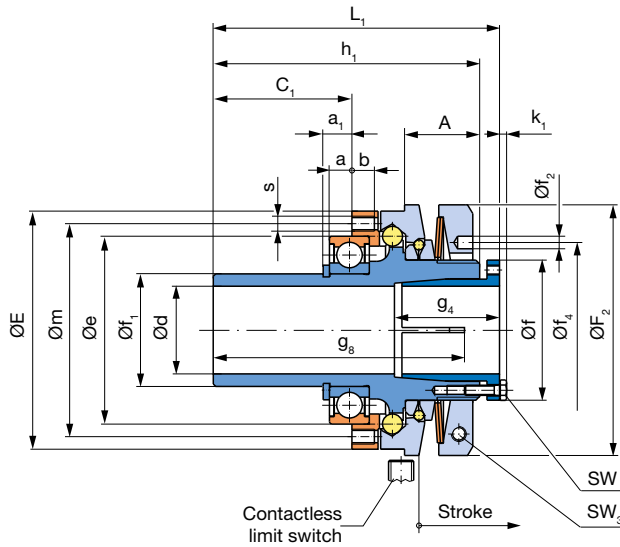

EAS[®]-Compact[®] overload
long protruding hub with keyway

Type 490._24.1
Sizes 01 to 3

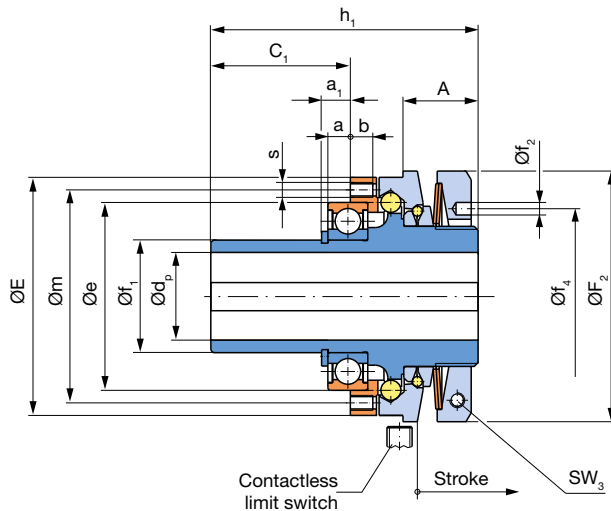

Order Number

		with cone bushing with keyway	1 2		4	Overload clutch		Torque adjustment value (Optional)								
__	/	4	9	0	.	__	__	4	.	1	/	__	/	__	/	__
▲			▲			▲	▲				▲			▲		
Sizes	Torque range ¹⁾					long protruding hub	1	Hub bore					With limit switch			
01	medium		5					Ø d ^{H7}					see			
to	high		6					Ø d ^{H7}					page 51			
3	very high		7					Ø d _p ^{H7}					(Option)			
	maximum		8													

Example: Order number 1 / 490.614.1 / 25 / 60 / limit switch 055.002.5

1) See Technical Data, limit torque for overload M_G

EAS®-Compact® overload clutch

Technical Data				Size ¹⁾				
				01	0	1	2	3
Limit torques for overload ¹⁾	Type 490.5_4.1	M _G	[Nm]	5 – 12.5	10 – 25	20 – 50	40 – 100	80 – 200
	Type 490.6_4.1	M _G	[Nm]	10 – 25	20 – 50	40 – 100	80 – 200	160 – 400
	Type 490.7_4.1	M _G	[Nm]	20 – 50	40 – 100	80 – 200	160 – 400	320 – 800
	Type 490.8_4.1	M _G	[Nm]	25 – 62.5	50 – 125	100 – 250	200 – 500	400 – 1000
Max. speed	n _{max}		[rpm]	8000	7000	6000	5000	4000
Thrust washer stroke on overload			[mm]	2.0	2.6	3.2	3.8	4.5

Mass moments of inertia and weights				Size				
				01	0	1	2	3
Hub-side	Type 490._14.1	I	[10 ⁻³ kgm ²]	0.397	1.000	2.382	4.680	10.888
	Type 490._24.1	I	[10 ⁻³ kgm ²]	0.391	0.974	2.296	4.464	10.389
Pressure flange-side	Type 490._14.1	I	[10 ⁻³ kgm ²]	0.093	0.234	0.643	1.306	2.649
	Type 490._24.1	I	[10 ⁻³ kgm ²]	0.093	0.234	0.643	1.306	2.649
Weights	Type 490._14.1	m	[kg]	1.02	1.77	2.86	4.16	6.42
	Type 490._24.1	m	[kg]	0.97	1.65	2.64	3.82	5.90

Screws and screw-on bores				Size				
				01	0	1	2	3
Tensioning screws in cone bushing	Number, dimensions	M	[mm]	6 x M4	6 x M4	8 x M4	8 x M5	8 x M6
	Wrench opening	SW	[mm]	7	7	7	8	10
	Tightening torque	T _A	[Nm]	4	4	4	8	12
Locking screw in adjusting nut	Number, dimensions	M ₃	[mm]	1 x M4	1 x M4	1 x M5	1 x M5	1 x M6
	Wrench opening	SW ₃	[mm]	3	3	4	4	5
	Tightening torque	T _A	[Nm]	3	5	9	9	15
Screw-on bores in pressure flange	Number, dimensions	s	[mm]	8 x M4	8 x M5	8 x M6	8 x M6 *	8 x M8 *
	* Screws quality class 12.9 must be used to secure the drive element.							

Dimensions [mm]	Size					
	01	0	1	2	3	
A	24	28	30	34	40	
a ²⁾	5	7	9	10	10	
a ₁	6.5	8.75	11.5	13	14	
b	6	7	9	10	12	
C ₁	33	43	55	67	73	
E	65	80	95	110	130	
e _{h5} ³⁾	47	62	75	90	100	
F ₂	70	85	100	115	135	
f	38	44	56	70	84	
f _{1,h6}	30	40	45	55	65	
f ₂	5	5	5	6	7	
f ₄	50	55	70	84	100	
Minimum shaft length	g ₄	34	39	42	48	53
	g ₈	61	75	95	108	124
h ₁	70	87	106	123	137	
k ₁	2.8	2.8	2.8	3.5	4.0	
L ₁ ⁴⁾	77	95	114	132	148	
m	56	71	85	100	116	

Bores [mm]		Size				
		01	0	1	2	3
d ^{5) 6)}	d _{min}	10	15	22	32	35
	d _{max}	20	25	35	45	55
d _P	d _{P min} ⁷⁾	12	15	22	28	32
	d _{P max} ⁸⁾	20	25	30	40	50

We reserve the right to make dimensional and constructional alterations.

- 1) Further sizes for smaller and larger torques available on request
- 2) Mounting tolerance + 0.1
- 3) Tolerance user-side H7
- 4) Dimensions in untensioned condition (shorter in tensioned condition)
- 5) Shaft tolerance up to Ø 38_{h6} over Ø 38_{h8}
- 6) Transmittable torques available with smaller bores on request
- 7) Smaller bores for low torques available on request
- 8) Larger bores available on request

EAS[®]-Compact[®] overload clutch

EAS[®]-Compact[®] overload torsionally rigid

Type 496.__4.0

Sizes 01 to 3

EAS[®]-side cone bushing,
ROBA[®]-DS-side shrink disk hub
Type 496._14.0, Sizes 01 to 3

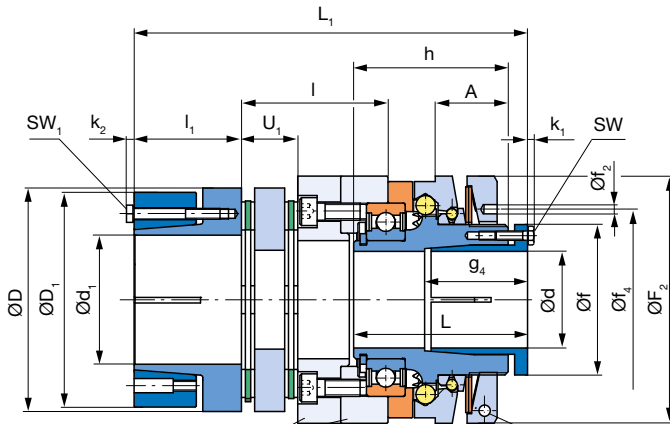

1-part flange Sizes 01 and 1
2-part flange Sizes 0, 2 and 3
Contactless limit switch
Stroke SW₃

All EAS[®]-Compact[®] clutches can be combined with almost all components of the ROBA[®]-DS backlash-free shaft coupling. The Types shown here represent only a selection of the most established designs.

For further combination possibilities, see page 43.

We are happy to advise you on the dimensioning and configuration of your optimum clutch.

EAS[®]-side key hub,
ROBA[®]-DS-side clamping hub with keyway
Type 496._24.0, Sizes 01 and 0

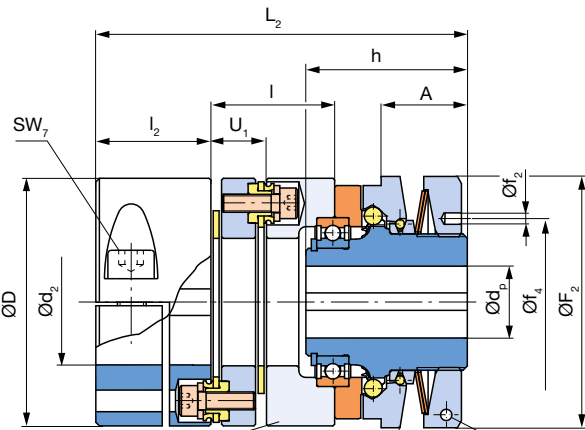

1-part flange Size 01
2-part flange Size 0
Contactless limit switch
Stroke SW₃

EAS[®]-side key hub,
ROBA[®]-DS-side key hub
Type 496._24.0, Sizes 1 to 3

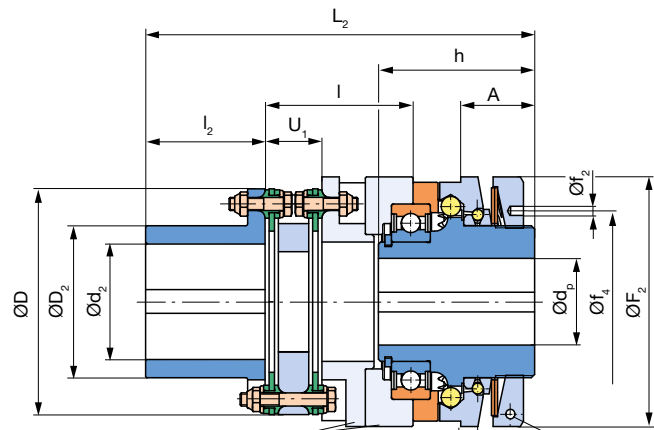

1-part flange Size 1
2-part flange Sizes 2 and 3
Contactless limit switch
Stroke SW₃

Order Number

EAS[®]-side	ROBA[®]-DS-side	1									Torque adjustment value (Optional)
Cone bushing	Shrink disk hub										
Key hub	Clamping hub with keyway (Sizes 01-0) / key hub (Sizes 1-3)	2			4	Overload clutch					

_ / 4 9 6 . _ _ 4 . 0 / _ / _ / _ / _											
Sizes	Torque range ¹⁾										
01	medium		5				Hub 1 bore	Hub 2 bore			With limit switch see page 51 (Option)
to	high		6				Ø d ^{H7}	Ø d ^{H7}			
3	very high maximum		7 8				Ø d ^{pH7}	Ø d ^{pH7}			

Example: Order number 1 / 496.614.0 / 30 / 30 / 60 / limit switch 055.002.5

1) See Technical Data, limit torque for overload M_G

EAS®-Compact® overload clutch

Technical Data				Size				
				01	0	1	2	3
Limit torques for overload	Type 496.5_4.0	M_G	[Nm]	5 – 12.5	10 – 25	20 – 50	40 – 100	80 – 200
	Type 496.6_4.0	M_G	[Nm]	10 – 25	20 – 50	40 – 100	80 – 200	160 – 400
	Type 496.7_4.0	M_G	[Nm]	20 – 50	40 – 100	80 – 200	160 – 400	320 – 800
	Type 496.8_4.0	M_G	[Nm]	25 – 62.5	50 – 125	100 – 250	200 – 500	400 – 1000
Max. speed	n_{max}	[rpm]	8000	7000	6000	5000	4000	
Thrust washer stroke on overload		[mm]	2.0	2.6	3.2	3.8	4.5	
Nominal torques, torsionally rigid coupling	T_{KN}	[Nm]	100	150	300	650	1100	
Permitted misalignments	axial ¹⁾	ΔK_a	[mm]	0.9	1.1	0.8	1.1	1.3
	radial	ΔK_r	[mm]	0.20	0.20	0.20	0.25	0.30
	angular	ΔK_w	[°]	2.0	2.0	1.4	1.4	1.4

Mass moments of inertia and weights				Size				
				01	0	1	2	3
EAS®-hub-side	Type 496_14.0	I	[10 ⁻³ kgm ²]	0.383	0.943	2.279	4.421	10.396
	Type 496_24.0	I	[10 ⁻³ kgm ²]	0.377	0.917	2.193	4.205	9.867
ROBA®-DS-side	Type 496_14.0	I	[10 ⁻³ kgm ²]	0.894	2.395	2.915	9.543	21.443
	Type 496_24.0	I	[10 ⁻³ kgm ²]	0.709	2.086	2.417	7.815	18.215
Weights	Type 496_14.0	m	[kg]	1.81	3.34	4.34	7.81	12.75
	Type 496_24.0	m	[kg]	1.65	3.07	4.01	7.12	14.94

Screws				Size				
				01	0	1	2	3
In cone bushing EAS®-side	Number, dimensions	M	[mm]	6 x M4	6 x M4	8 x M4	8 x M5	8 x M6
	Wrench opening	SW	[mm]	7	7	7	8	10
	Tightening torque	T_A	[Nm]	4	4	4	8	12
Locking screw in adjusting nut	Number, dimensions	M_3	[mm]	1 x M4	1 x M4	1 x M5	1 x M5	1 x M6
	Wrench opening	SW_3	[mm]	3	3	4	4	5
	Tightening torque	T_A	[Nm]	3	5	9	9	15
In shrink disk ROBA®-DS-side	Number, dimensions	M_1	[mm]	4 x M5	6 x M5	6 x M5	6 x M5	6 x M6
	Wrench opening	SW_1	[mm]	8	8	8	8	10
	Tightening torque	T_A	[Nm]	6	6	6	8.5	10
In clamping hub ROBA®-DS-side	Number, dimensions	M_7	[mm]	1 x M8	1 x M8	-	-	-
	Wrench opening	SW_7	[mm]	6	6	-	-	-
	Tightening torque	T_A	[Nm]	33	33	-	-	-

Dimensions [mm]	Size				
	01	0	1	2	3
A	24	28	30	34	40
D	69	79	77	104	123
D ₁	68	78	77	100	115
D ₂	-	-	50	70	80
F ₂	70	85	100	115	135
f	38	44	56	70	84
f ₂	5	5	5	6	7
f ₄	50	55	70	84	100
Min. shaft length g ₄	34	39	42	48	53
h	45	55	65	72	82
k ₁	2.8	2.8	2.8	3.5	4.0
k ₂	3.5	3.5	3.5	3.5	4.0
L ²⁾	52	63	73	81	93
L ₁ ²⁾	110.3	139.3	147.1	183.2	215
L ₂	103.3	127.3	139.2	179.2	214
l	34.3	49.8	48.2	68.2	85
l ₁	32	37.5	40	50	55
l ₂	32	33.5	40	55	65
U ₁	15.3	15.8	21.2	26.2	34

Bores [mm]		Size					
		01	0	1	2	3	
EAS®-side	d ³⁾	d _{min}	10	15	22	32	35
		d _{max}	20	25	35	45	55
	d _P	d _{P min}	12	15	22	28	32
		d _{P max}	20	25	30	40	50
ROBA®-DS-side	d ₁ ⁴⁾	d _{1 min}	19	25	25	40	45
		d _{1 max}	38	45	45	60	70
	d ₂	d _{2 min}	19 ⁵⁾	25 ⁵⁾	16	25	30
		d _{2 max}	35 ⁵⁾	42 ⁵⁾	32	50	55

We reserve the right to make dimensional and constructional alterations.

- 1) Only permitted as a static or virtually static value.
- 2) Dimensions in untensioned condition (shorter in tensioned condition)
- 3) Shaft tolerance up to $\varnothing 38_{h6}$ over $\varnothing 38_{h8}$
- 4) Recommended shaft tolerance
- 5) Recommended shaft tolerance

EAS[®]-Compact[®] overload clutch

EAS[®]-Compact[®] overload torsionally rigid

Type 496.__4.2

Sizes 4 and 5

EAS[®]-side cone bushing,
ROBA[®]-DS-side shrink disk hub
Type 496._14.2

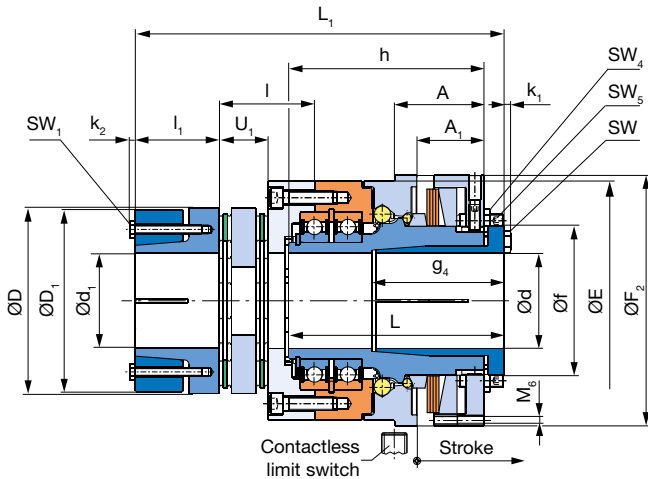

All EAS[®]-Compact[®] clutches can be combined with almost all components of the ROBA[®]-DS backlash-free shaft coupling. The Types shown here represent only a selection of the most established designs.

For further combination possibilities, see page 43.

We are happy to advise you on the dimensioning and configuration of your optimum clutch.

EAS[®]-side key hub,
ROBA[®]-DS-side key hub
Type 496._24.2

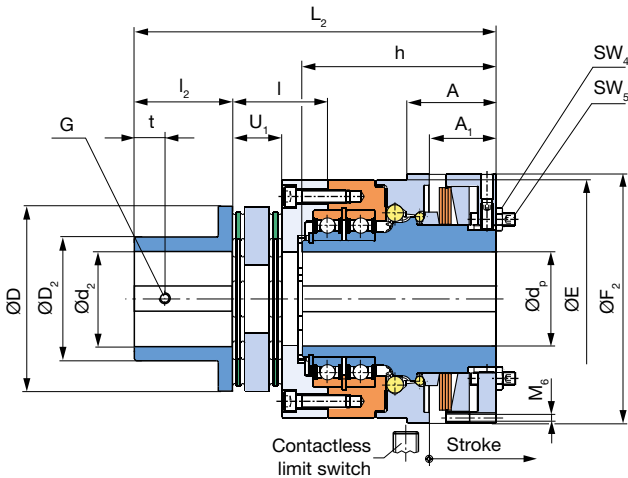

Order Number

EAS [®] -side Cone bushing	ROBA [®] -DS-side Shrink disk hub	1	4	Overload clutch	Torque adjustment value (Optional)
Key hub	Key hub	2			

___ / 4 9 6 . ___ ___ 4 . 2 / ___ / ___ / ___ / ___

Sizes 4 and 5	Torque range ¹⁾ medium high very high maximum	5 6 7 8	2-bearing design	2	Hub 1 bore Ø d ^{H7} Ø d _p ^{H7}	Hub 2 bore Ø d ₁ ^{H7} Ø d ₂ ^{H7}	With limit switch see page 51 (Option)
-------------------------------	---	------------------	------------------	---	--	---	---

Example: Order number 5 / 496.714.2 / 70 / 70 / 1500 / limit switch 055.002.5

1) See Technical Data, limit torque for overload M_G

EAS®-Compact® overload clutch

Technical Data				Size					
				4			5		
Limit torques for overload	Type 496.5_4.2	M_G	[Nm]	120	–	300	240	–	600
	Type 496.6_4.2	M_G	[Nm]	240	–	600	480	–	1200
	Type 496.7_4.2	M_G	[Nm]	480	–	1200	960	–	2400
	Type 496.8_4.2	M_G	[Nm]	600	–	1500	1200	–	3000
Max. speed		n_{max}	[rpm]	3500			3000		
Thrust washer stroke on overload			[mm]	5.5			6.5		
Nominal torques, torsionally rigid coupling		T_{KN}	[Nm]	1600			3500		
Permitted misalignments	axial ¹⁾	ΔK_a	[mm]	1.5			1.2		
	radial	ΔK_r	[mm]	0.30			0.25		
	angular	ΔK_w	[°]	1.4			1.0		

Mass moments of inertia and weights				Size					
				4			5		
EAS®-hub-side	Type 496._14.2	I	[10 ⁻³ kgm ²]	39.730			120.834		
	Type 496._24.2	I	[10 ⁻³ kgm ²]	37.215			112.399		
ROBA®-DS-side	Type 496._14.2	I	[10 ⁻³ kgm ²]	32.310			147.080		
	Type 496._24.2	I	[10 ⁻³ kgm ²]	26.050			128.580		
Weights	Type 496._14.2	m	[kg]	27.30			52.18		
	Type 496._24.2	m	[kg]	26.10			48.60		

Screws				Size					
				4			5		
In cone bushing EAS®-side	Number, dimensions	M	[mm]	8 x M8			8 x M10		
	Wrench opening	SW	[mm]	13			16		
	Tightening torque	T_A	[Nm]	25			71		
In shrink disk ROBA®-DS-side	Number, dimensions	M_1	[mm]	6 x M8			8 x M8		
	Wrench opening	SW_1	[mm]	13			13		
	Tightening torque	T_A	[Nm]	25			35		
Pins/threads in adjusting nut	Wrench opening	SW_4	[mm]	18			18		
	Wrench opening	SW_5	[mm]	6			6		
	Number, dimensions	M_6	[mm]	3 x M8			3 x M8		

Dimensions [mm]	Size	
	4	5
A	62.5	80
A ₁	46.5	60
D	143	167
D ₁	143	164
D ₂	100	121
E	166	215
F ₂	175	225
f	100	134
G	²⁾	M12
Min. shaft length g ₄	93	118
h	145	175
k ₁	5.3	6.4
k ₂	5.3	5.3
L ³⁾	160	193
L ₁ ³⁾	267	331
L ₂	267	328
l	68	86
l ₁	60	75
l ₂	75	90
t	21	25
U ₁	35.2	44.4

Bores [mm]		Size		
		4	5	
EAS®- side	d ⁴⁾	d _{min}	40	45
		d _{max}	65	85
	d _p	d _{p min}	40	45
		d _{p max}	65	80
ROBA®-DS - side	d ₁ ⁵⁾	d _{1 min}	55	50
		d _{1 max}	90	85
	d ₂	d _{2 min}	35	45
		d _{2 max}	70	90

We reserve the right to make dimensional and constructional alterations.

- 1) Only permitted as a static or virtually static value
- 2) Up to Ø 44 M8, over Ø 44 M10
- 3) Dimensions in untensioned condition (shorter in tensioned condition)
- 4) Shaft tolerance $_{H6}$
- 5) Recommended shaft tolerance $_{g6}$

EAS®-Compact® overload clutch

EAS®-Compact® overload lastic backlash-free

Type 494._4._

EAS®-side cone bushing, ROBA®-ES-side shrink disk hub

Sizes 01 to 4

Type 494._14._, Sizes 01 to 3

Type 494._14._, Size 4

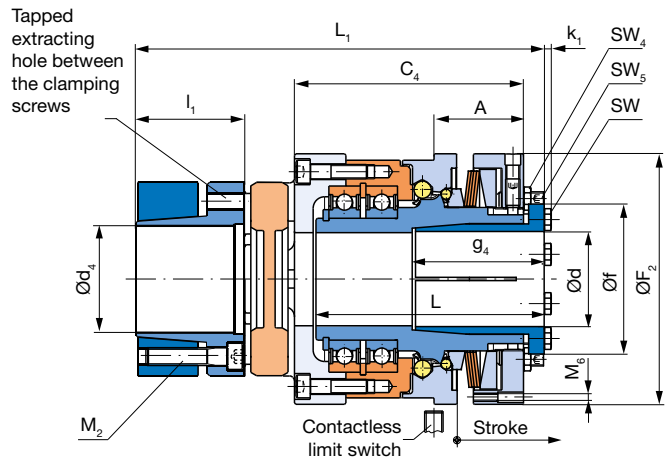
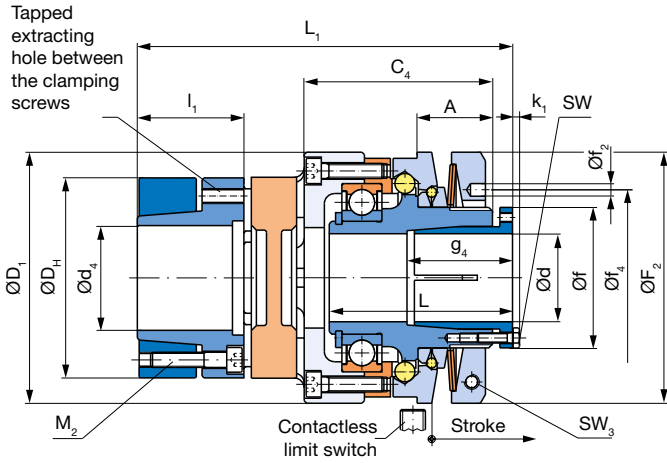

The missing dimensions ($\text{Ø}D_1$ and $\text{Ø}D_H$) are identical to Sizes 01 to 3, Type 494._14._

EAS®-side cone bushing, ROBA®-ES-side clamping hub

Type 494._04._, Sizes 01 to 3

Type 494._04._, Size 4

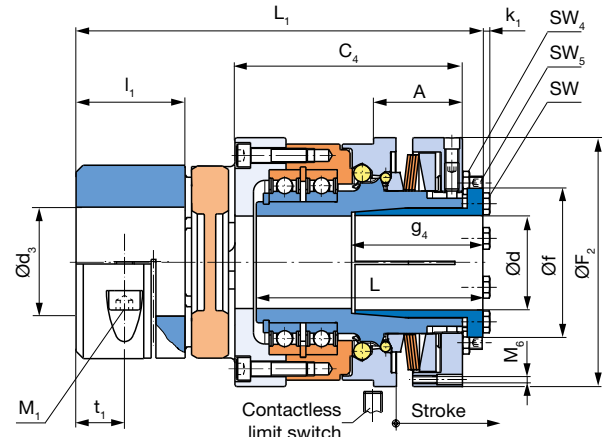
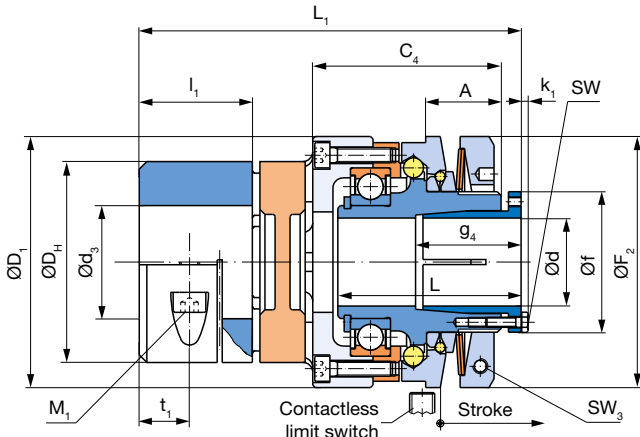

The missing dimensions ($\text{Ø}D_1$ and $\text{Ø}D_H$) are identical to Sizes 01 to 3, Type 494._04._

Order Number

EAS®-side	ROBA®-ES-side												Torque adjustment value (Optional)
Cone bushing	Clamping hub	0											
Cone bushing	Shrink disk hub	1											
						4	Overload clutch						
<p style="text-align: center;">_ / 4 9 4 . _ _ 4 . _ / _ / _ / _ / _</p>													
Sizes	Torque range ¹⁾			Flexible coupling			Hub 1 bore		Hub 2 bore				With limit switch
01	medium	5		92 Shore A	3		$\text{Ø} d^{H7}$		$\text{Ø} d_3^{F7}$				see
to	high	6		98 Shore A	4				$\text{Ø} d_4^{H7}$				page 51
4	very high	7		64 Shore D	6								(Option)
	maximum	8											

Example: Order number 1 / 494.614.3 / 22 / 25 / 60 / limit switch 055.002.5

- See Technical Data, limit torque for overload M_G
- The transmittable torques on the flexible coupling “ T_{KN} ” are dependent on factors such as temperature, torsional rigidity, etc., see also coupling dimensioning ROBA®-ES catalogue K.940.V._ or contact the manufacturer.
Furthermore, the transmittable torques of the flexible coupling are

- dependent on the bore diameter d_3 or d_4 , see also Table 1 on page 50.
- Dimensions in untensioned condition (shorter in tensioned condition)
- Shaft tolerance up to $\text{Ø} 38_{H6}$, over $\text{Ø} 38_{H6}$
- Transmittable torques available with smaller bores on request
- Shaft tolerance up to $\text{Ø} 40_{F6}$

EAS®-Compact® overload clutch

Technical Data				Size						
				01	0	1	2	3	4	
Limit torques ²⁾ for overload	Type 494.5_4_	M _G	[Nm]	5 – 12.5	10 – 25	20 – 50	40 – 100	80 – 200	120 – 300	
	Type 494.6_4_	M _G	[Nm]	10 – 25	20 – 50	40 – 100	80 – 200	160 – 400	240 – 600	
	Type 494.7_4_	M _G	[Nm]	20 – 50	40 – 100	80 – 200	160 – 400	320 – 800	480 – 1200	
	Type 494.8_4_	M _G	[Nm]	25 – 62.5	50 – 125	100 – 250	200 – 500	400 – 1000	600 – 1500	
Max. speed	n _{maxi}	[rpm]	8000	7000	6000	5000	4000	3500		
Thrust washer stroke on overload		[mm]	2.0	2.6	3.2	3.8	4.5	5.5		
Nominal and maximum torques ²⁾ , flexible coupling	92 Shore A	T _{KN} /T _{K max}	[Nm]	35 / 70	95 / 190	190 / 380	265 / 530	310 / 620	900 / 1800	
	98 Shore A	T _{KN} /T _{K max}	[Nm]	60 / 120	160 / 320	325 / 650	450 / 900	525 / 1050	1040 / 2080	
	64 Shore D	T _{KN} /T _{K max}	[Nm]	75 / 150	200 / 400	405 / 810	560 / 1120	655 / 1310	1250 / 2500	
Permitted misalignments	axial	ΔK _a	[mm]	1.4	1.5	1.8	2.0	2.1	2.6	
		radial	92 Shore A	ΔK _r	[mm]	0.14	0.15	0.17	0.19	0.21
	98 Shore A		ΔK _r	[mm]	0.10	0.11	0.12	0.14	0.16	0.18
	64 Shore D		ΔK _r	[mm]	0.07	0.08	0.09	0.10	0.11	0.13
	angular	92 Shore A	ΔK _w	[°]	1.0	1.0	1.0	1.0	1.0	1.0
		98 Shore A	ΔK _w	[°]	0.9	0.9	0.9	0.9	0.9	0.9
64 Shore D		ΔK _w	[°]	0.8	0.8	0.8	0.8	0.8	0.8	

Mass moments of inertia and weights				Size					
				01	0	1	2	3	4
EAS®-hub-side	Type 494_4_	I	[10 ⁻³ kgm ²]	0.383	0.943	2.279	4.421	10.396	39.730
ROBA®-ES-side	Type 494_14_	I	[10 ⁻³ kgm ²]	0.378	0.832	2.277	7.25	14.167	61.674
	Type 494_04_	I	[10 ⁻³ kgm ²]	0.320	0.691	1.843	7.40	14.529	62.369
Weights	Type 494_14_	m	[kg]	1.38	2.16	3.64	6.69	10.11	27.61
	Type 494_04_	m	[kg]	1.27	1.98	3.25	6.81	10.42	27.67

Screws				Size					
				01	0	1	2	3	4
In cone bushing EAS®-side	Number, dimensions	M	[mm]	6 x M4	6 x M4	8 x M4	8 x M5	8 x M6	8 x M8
	Wrench opening	SW	[mm]	7	7	7	8	10	13
	Tightening torque	T _A	[Nm]	4	4	4	8	12	25
In shrink disk ROBA®-ES-side	Number, dimensions	M ₂	[mm]	4 x M5	8 x M5	8 x M6	4 x M8	4 x M8	4 x M12
	Wrench opening	SW ₂	[mm]	4	4	5	6	8	10
	Tightening torque	T _A	[Nm]	6	6	10.5	25	30	120
In clamping hub ROBA®-ES-side	Number, dimensions	M ₁	[mm]	1 x M6	1 x M8	1 x M8	1 x M10	1 x M12	1 x M14
	Wrench opening	SW ₁	[mm]	5	6	6	8	10	12
	Tightening torque	T _A	[Nm]	10	25	25	70	120	200
Locking screw in adjusting nut Sizes 01 - 3	Number, dimensions	M ₃	[mm]	1 x M4	1 x M4	1 x M5	1 x M5	1 x M6	-
	Wrench opening	SW ₃	[mm]	3	3	4	4	5	-
	Tightening torque	T _A	[Nm]	3	5	9	9	15	-
Pins/threads in adjusting nut Size 4	Wrench opening	SW ₄	[mm]	-	-	-	-	-	18
	Wrench opening	SW ₅	[mm]	-	-	-	-	-	6
	Number, dimensions	M ₆	[mm]	-	-	-	-	-	3 x M8

Dimensions [mm]	Size					
	01	0	1	2	3	4
A	24	28	30	34	40	62.5
C ₄	52	63.5	75	82	94	160
D ₁	70	85	100	115	135	175
D _H	55	65	80	95	105	135
F ₂	70	85	100	115	135	175
f	38	44	56	70	84	100
f ₂	5	5	5	6	7	-
f ₄	50	55	70	84	100	-
Min. shaft length g ₄	34	39	42	48	53	93
k ₁	2.8	2.8	2.8	3.5	4.0	5.3
L ³⁾	52	63	73	81	93	160
L ₁ ³⁾	107	126.5	152	167	189	270
l ₁	30	35	45	50	56	75
t ₁	12	13.5	20	20	21	27.5

Bores [mm]		Size						
		01	0	1	2	3	4	
EAS®- side	d ^{4) 5)}	d _{min}	10	15	22	32	35	40
		d _{max}	20	25	35	45	55	65
ROBA®-ES - side	d ₃ ²⁾	d _{3 min}	15	19	20	28	35	45
		d _{3 max}	28	35	45	50	55	80
	d ₄ ²⁾	d _{4 min}	15	19	20	28	35 ⁶⁾	45
		d _{4 max}	28	38	45	50	60 ⁶⁾	75

We reserve the right to make dimensional and constructional alterations.

EAS[®]-Compact[®] overload clutch

EAS[®]-Compact[®] overload lastic backlash-free

Type 494._24._
Sizes 01 to 4

EAS[®]-side key hub, ROBA[®]-ES-side key hub
Type 494._24._, Sizes 01 to 3

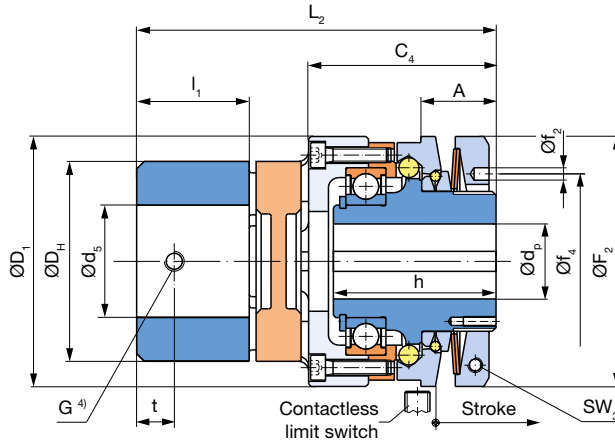

Type 494._24._, Size 4

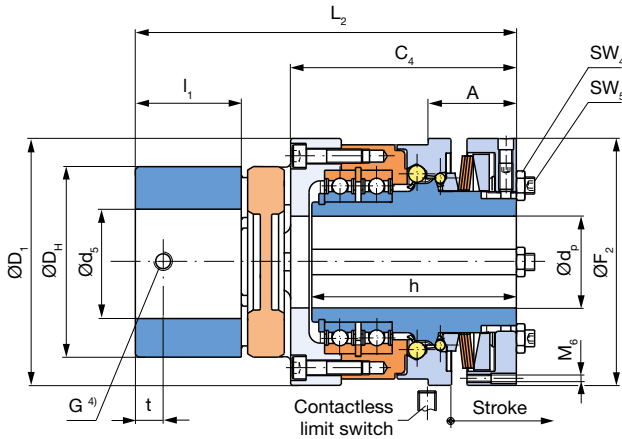

Order Number

EAS [®] -side Key hub	ROBA [®] -ES-side Key hub	2	4	Overload clutch	Torque adjustment value (Optional)
-----------------------------------	---------------------------------------	---	---	-----------------	--

___ / 4 9 4 . ___ 2 4 . ___ / ___ / ___ / ___ / ___

Sizes 01 to 4	Torque range ¹⁾ medium high very high maximum	5 6 7 8	Flexible coupling 92 Shore A 98 Shore A 64 Shore D	3 4 6	Hub 1 bore Ø d _p ^{H7}	Hub 2 bore Ø d ₅ ^{H7}	With limit switch see page 51 (Option)
-------------------------------	---	------------------	--	-------------	---	---	---

Example: Order number 1 / 494.624.3 / 22 / 25 / 60 / limit switch 055.002.5

1) See Technical Data, limit torque for overload M_G

EAS®-Compact® overload clutch

Technical Data				Size						
				01	0	1	2	3	4	
Limit torques ¹⁾ for overload	Type 494.524._	M_G	[Nm]	5 – 12.5	10 – 25	20 – 50	40 – 100	80 – 200	120 – 300	
	Type 494.624._	M_G	[Nm]	10 – 25	20 – 50	40 – 100	80 – 200	160 – 400	240 – 600	
	Type 494.724._	M_G	[Nm]	20 – 50	40 – 100	80 – 200	160 – 400	320 – 800	480 – 1200	
	Type 494.824._	M_G	[Nm]	25 – 62.5	50 – 125	100 – 250	200 – 500	400 – 1000	600 – 1500	
Max. speed	n_{max}	[rpm]		8000	7000	6000	5000	4000	3500	
Thrust washer stroke on overload			[mm]	2.0	2.6	3.2	3.8	4.5	5.5	
Nominal and maximum torques ¹⁾ , flexible coupling	92 Shore A	$T_{KN}/T_{K max}$	[Nm]	35 / 70	95 / 190	190 / 380	265 / 530	310 / 620	900 / 1800	
	98 Shore A	$T_{KN}/T_{K max}$	[Nm]	60 / 120	160 / 320	325 / 650	450 / 900	525 / 1050	1040 / 2080	
	64 Shore D	$T_{KN}/T_{K max}$	[Nm]	75 / 150	200 / 400	405 / 810	560 / 1120	655 / 1310	1250 / 2500	
Permitted misalignments	axial	ΔK_a	[mm]	1.4	1.5	1.8	2.0	2.1	2.6	
	radial	92 Shore A	ΔK_r	[mm]	0.14	0.15	0.17	0.19	0.21	0.25
		98 Shore A	ΔK_r	[mm]	0.10	0.11	0.12	0.14	0.16	0.18
	angular	92 Shore A	ΔK_w	[°]	1.0	1.0	1.0	1.0	1.0	1.0
		98 Shore A	ΔK_w	[°]	0.9	0.9	0.9	0.9	0.9	0.9
	64 Shore D	ΔK_w	[°]	0.8	0.8	0.8	0.8	0.8	0.8	

Mass moments of inertia and weights				Size					
				01	0	1	2	3	4
EAS®-hub-side	Type 494._24._	I	[10 ⁻³ kgm ²]	0.377	0.917	2.193	4.205	9.867	37.215
ROBA®-ES-side	Type 494._24._	I	[10 ⁻³ kgm ²]	0.321	0.695	1.844	7.39	14.519	62.873
Weights	Type 494._24._	m	[kg]	1.23	1.92	3.26	6.73	10.28	27.19

Screws				Size					
				01	0	1	2	3	4
Locking screw in adjusting nut Sizes 01 - 3	Number, dimensions	M_3	[mm]	1 x M4	1 x M4	1 x M5	1 x M5	1 x M6	-
	Wrench opening	SW_3	[mm]	3	3	4	4	5	-
	Tightening torque	T_A	[Nm]	3	5	9	9	15	-
Pins/threads in adjusting nut Size 4	Wrench opening	SW_4	[mm]	-	-	-	-	-	18
	Wrench opening	SW_5	[mm]	-	-	-	-	-	6
	Number, dimensions	M_6	[mm]	-	-	-	-	-	3 x M8

Dimensions [mm]	Size					
	01	0	1	2	3	4
A	24	28	30	34	40	62.5
C_4	52	63.5	75	82	94	160
D_1	70	85	100	115	135	175
D_H	55	65	80	95	105	135
F_2	70	85	100	115	135	175
f_2	5	5	5	6	7	-
f_4	50	55	70	84	100	-
G ⁴⁾	M5	M6	M8	M8	M8	M10
h	45	55	65	72	82	145
L_2	100	118.5	144	158	178	270
l_1	30	35	45	50	56	75
t	10	15	15	20	25	20

Bores [mm]		Size						
		01	0	1	2	3	4	
EAS®- side	d_p	$d_{p min}^{2)}$	12	15	22	28	32	40
		$d_{p max}^{3)}$	20	25	30	40	50	65
ROBA®- ES-side	d_s	$d_{s min}$	8	10	12	14	20	38
		$d_{s max}$	28	38	45	55	60	80

We reserve the right to make dimensional and constructional alterations.

- 1) The transmittable torques on the flexible coupling " T_{KN} " are dependent on factors such as temperature, torsional rigidity, etc., see also coupling dimensioning ROBA®-ES catalogue K.940.V_ _ or contact the manufacturer.
- 2) Smaller bores for smaller torques available on request
- 3) Larger bores available on request
- 4) Keyway 180° offset to "G"

EAS®-Compact® overload clutch

EAS®-Compact® overload lastic

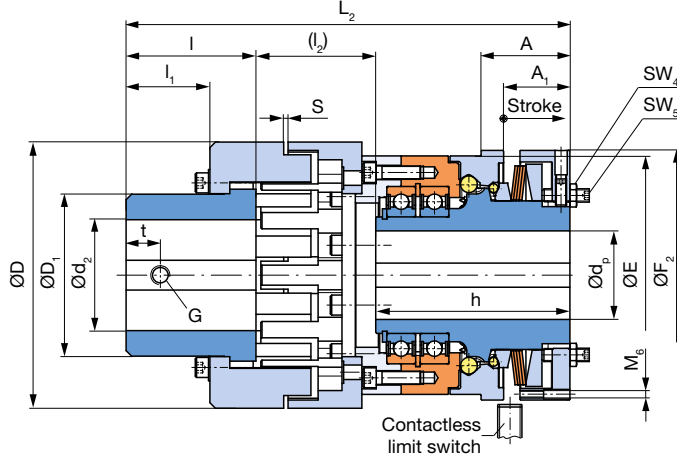
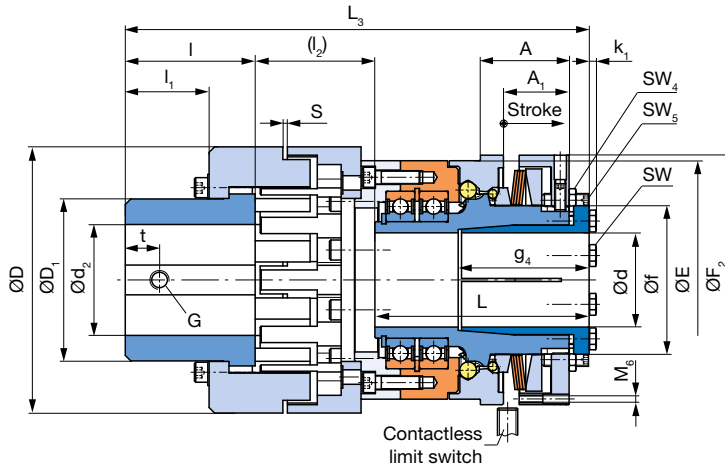
Type 494._4.2
Size 5
Key hub on both sides
Type 494._24.2

EAS®-side cone bushing,
lastic-side key hub
Type 494._34.2

Order Number

EAS®-side	lastic-side	2	4	Overload clutch	Torque adjustment value (Optional)
Key hub	Key hub	3			
Cone bushing	Key hub				

__ / 4 9 4 . __ __ 4 . 2 / __ / __ / __ / __

Size 5	Torque range ¹⁾ medium high very high maximum	5 6 7 8	2-bearing design	2	Hub 1 bore Ø d ^{H7} Ø d _p ^{H7}	Hub 2 bore Ø d ₂ ^{H7}	With limit switch see page 51 (Option)
------------------	---	--	-------------------------	----------	--	---	--

Example: Order Number 5 / 494.624.2 / 60 / 60 / 800 / limit switch 055.002.5

 1) See Technical Data, limit torque for overload M_G

EAS®-Compact® overload clutch

Technical Data				Size	
				5	
Limit torques for overload	Type 494.5_4.2	M_G	[Nm]	240 – 600	
	Type 494.6_4.2	M_G	[Nm]	480 – 1200	
	Type 494.7_4.2	M_G	[Nm]	960 – 2400	
	Type 494.8_4.2	M_G	[Nm]	1200 – 3000	
Max. speed		n_{max}	[rpm]	3000	
Thrust washer stroke on overload			[mm]	6.5	
Nominal torques, flexible coupling	Type 494.5_4.2	T_{KN}	[Nm]	2400	
	Type 494.6_4.2	T_{KN}	[Nm]	2400	
	Type 494.7_4.2	T_{KN}	[Nm]	2400	
	Type 494.8_4.2	T_{KN}	[Nm]	3700	
Permitted misalignments ²⁾	axial	ΔK_a	[mm]	2.0	
	radial	ΔK_r	[mm]	0.3	
	angular	ΔK_w	[°]	0.07	

Mass moments of inertia and weights				Size	
				5	
EAS®-hub-side	Type 494._ 24.2	I	[10 ⁻³ kgm ²]	112.399	
	Type 494._ 34.2	I	[10 ⁻³ kgm ²]	120.834	
lastic-side	Type 494._ 4.2	I	[10 ⁻³ kgm ²]	420.870	
Weights	Type 494._ 24.2	m	[kg]	69.780	
	Type 494._ 34.2	m	[kg]	70.150	

Screws				Size	
				5	
In cone bushing EAS®-side	Number, dimensions	M	[mm]	8 x M10	
	Wrench opening	SW	[mm]	16	
	Tightening torque	T_A	[Nm]	71	
Pins/threads in adjusting nut	Wrench opening	SW ₄	[mm]	18	
	Wrench opening	SW ₅	[mm]	6	
	Number, dimensions	M ₆	[mm]	3 x M8	

Dimensions [mm]	Size	
	5	
A	80	
A ₁	60	
D	240	
D ₁	146	
E	215	
F ₂	225	
f	134	
G	M12	
g ₄	118	
h	175	
k ₁	6.4	
L ¹⁾	193	
L ₂	400	
L ₃ ¹⁾	418	
l	117	
l ₁	75.5	
l ₂	108	
S	4	
t	35	

Bores [mm]			Size	
			5	
EAS®-side	d _p	d _{p min}	45	
		d _{p max}	80	
lastic-side	d	d _{min}	45	
		d _{max}	85	
lastic-side	d ₂	d _{2 min}	60	
		d _{2 max}	100	

We reserve the right to make dimensional and constructional alterations.

- 1) Dimensions in untensioned condition (shorter in tensioned condition)
- 2) The values refer to 1500 rpm.

EAS®-Compact® Options

EAS®-Compact® with adjusting nut for radial torque adjustment

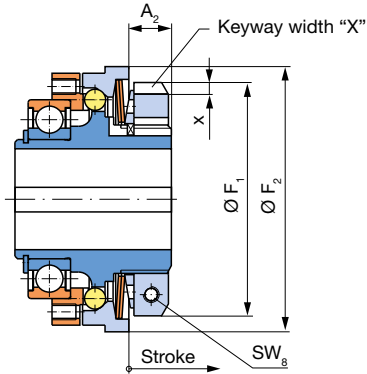

The EAS®-Compact® can be equipped with an adjusting nut for radial torque adjustment if the clutch cannot be accessed axially due to narrow installation conditions.

On this variant, the graduation for reading and adjusting the torque is mounted radially visible on the outer diameter.

Dimensions [mm]	Size				
	01	0	1	2	3
A ₂	12	13.5	16	17	20.5
F ₁	59	73	88	104	125
F ₂	70	85	100	115	135
X	6	7	7	8	10
x	3	4	4	4.5	4

EAS®-Compact® with clamping ring

EAS®-Compact® clutches with clamping ring hub can be mounted extremely quickly and easily onto the shaft. The slotted clamping ring is tensioned using one single screw. Due to the equipment with an adjusting nut for radial torque adjustment, the limit torque for overload can be altered even in installed condition.

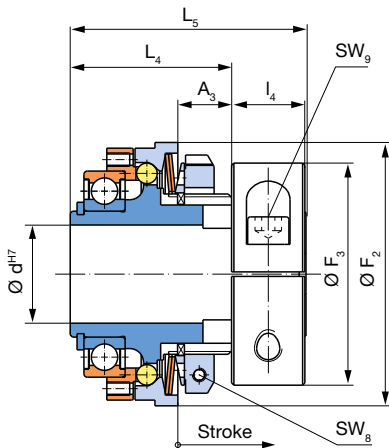

Dimensions [mm]	Size				
	01	0	1	2	3
A ₃	15.5	19	20.5	23.5	26
F ₂	70	85	100	115	135
F ₃	60	72	84	97	115
L ₄	43.5	53.5	63.5	70.5	80.5
L ₅	65	77	90	103	117
I ₄	18	22	26	32	36

Bores [mm]	Size					
	01	0	1	2	3	
d ^{H7} 1)	d _{min}	10	15	22	32	35
	d _{max}	25	32	40	45	55

1) For transmittable torques dependent on bore, see Table 1.

Bore	Size				
	01	0	1	2	3
Ø 10	44	-	-	-	-
Ø 12	52	-	-	-	-
Ø 14	61	-	-	-	-
Ø 16	69	101	-	-	-
Ø 18	78	113	-	-	-
Ø 20	87	126	-	-	-
Ø 22	96	138	199	-	-
Ø 25	109	168	226	327	-
Ø 28	-	201	253	366	523
Ø 30	-	216	290	420	561
Ø 32	-	230	325	470	598
Ø 35	-	-	355	515	700
Ø 38	-	-	386	559	798
Ø 40	-	-	406	588	840
Ø 45	-	-	-	661	945
Ø 50	-	-	-	-	1050
Ø 55	-	-	-	-	1155

Table 1

Screws				Size				
				01	0	1	2	3
Locking screw in adjusting nut	Number, dimensions	M ₈	[mm]	1 x M4	1 x M5	1 x M6	1 x M6	1 x M8
	Wrench opening	SW ₈	[mm]	3	4	5	5	6
	Tightening torque	T _A	[Nm]	3	5.5	9.5	9.5	23
In the clamping ring	Number, dimensions	M ₉	[mm]	1 x M6	1 x M8	1 x M10	1 x M12	1 x M14
	Wrench opening	SW ₉	[mm]	5	6	8	10	12
	Tightening torque	T _A	[Nm]	16	40	79	135	220

EAS[®]-Compact[®] Options

EAS[®]-Compact[®] torsionally rigid Modular Structure

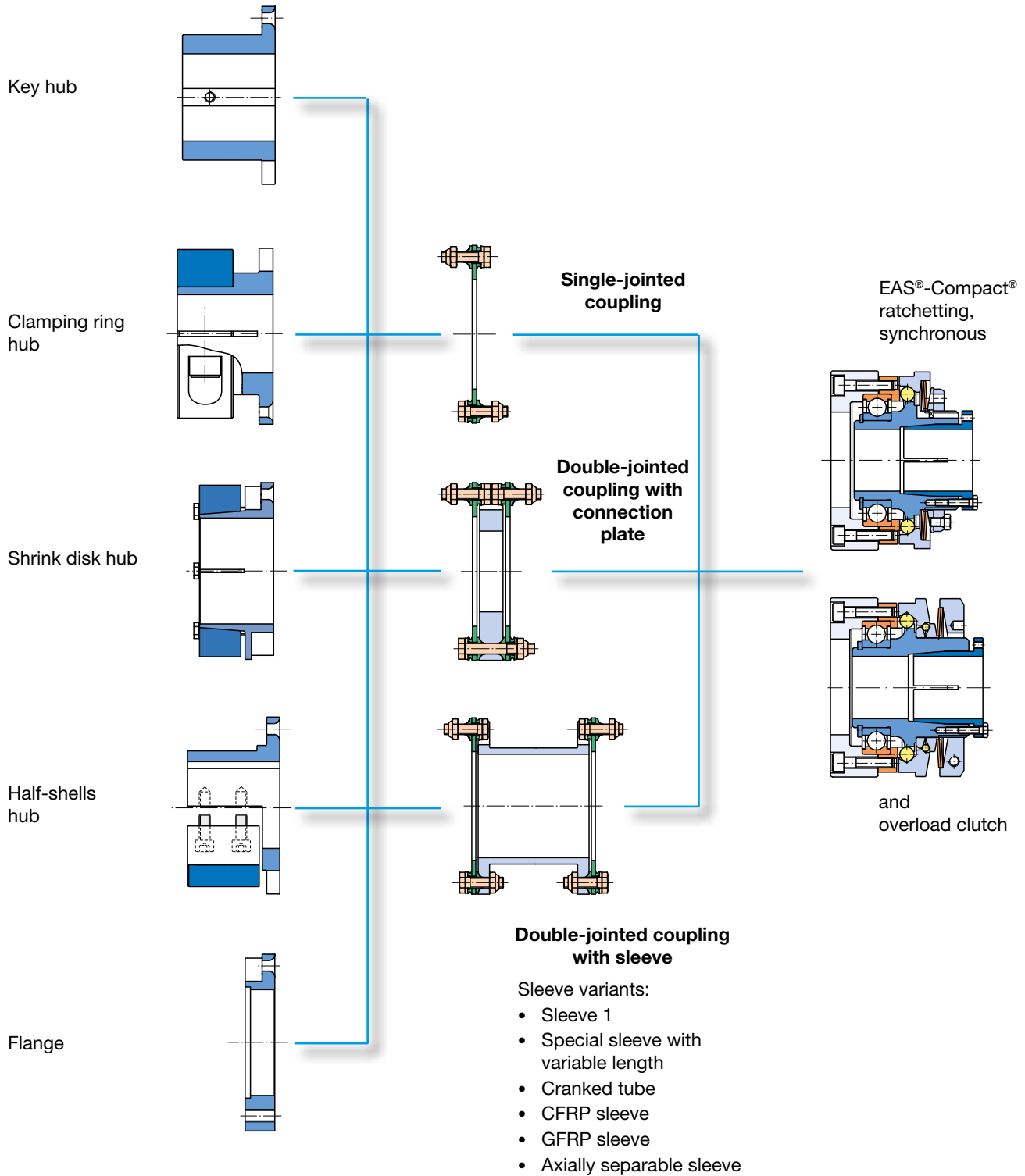

EAS[®]-Compact[®] ratchetting, synchronous and overload clutches can be combined with almost all components of the ROBA[®]-DS backlash-free shaft coupling. For a current selection of different Types, please see pages 16 and 17 as well as pages 32 to 35.

We are happy to advise you on the dimensioning and configuration of your optimum design.

Technical Explanations

Readable Torque Adjustment

The EAS®-Compact® overload clutch offers easily readable torque adjustment on the adjusting nut (for Sizes 01 to 3). This readability makes adjusting the torque far more simple, and also allows easy checks on the set release value on the installed clutch.

- The limit torque can be finely adjusted and accurately read due to the adjusting nut with the fine thread and the easily-readable graduation scale.
- The positive-locking (or frictionally-locking) safeguard on the adjusting nut protects against self-turning, inadvertent adjustment of the set limit torque. The integral blocking protection prevents the cup springs from becoming spring-bound.

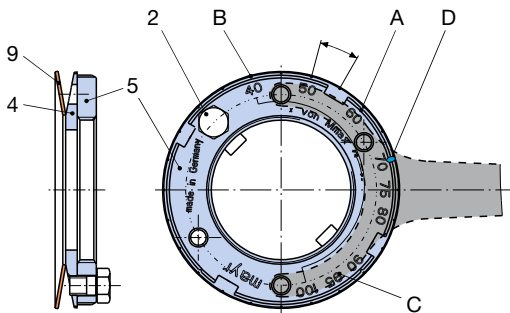

Fig. 1: EAS®-Compact® ratchetting and synchronous clutch

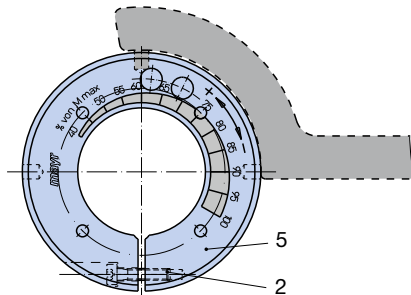

Fig. 2: EAS®-Compact® overload clutch

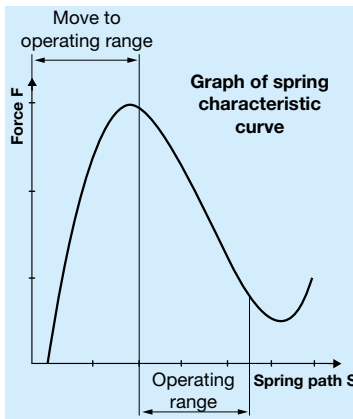

Fig. 3
(The diagram only serves as an example)

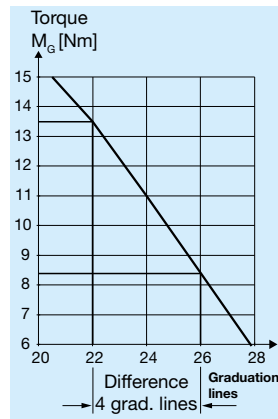

Fig. 4
(The diagram only serves as an example)



Depending on the drive and the drive constellation, torque peaks (e.g. via start-up torque impacts on asynchronous motors) can occur which lie substantially above the system (motor) operating torque. This behaviour is to be taken into account customer-side when dimensioning or adjusting the clutch.

Torque Adjustment

Adjustment takes place by turning the adjusting nut (5) (Sizes 03 to 3) or the set screws (6) (Sizes 4 and 5).

The installed cup springs (9) are operated in the negative range of the characteristic curve (Fig. 3). A stronger pre-tension produces a dropping in spring force. Turning the adjusting nut (5) (Sizes 03 to 3) or the set screws (6) (Sizes 4 and 5) clockwise therefore produces a decrease in spring force. Turning it anti-clockwise produces an increase in torque (facing direction towards the adjusting nut (5) – Figs. 1 and 2).

If no other torque adjustment is requested customer-side, the EAS®-Compact® ratchetting, synchronous and overload clutch is generally set and marked (calibrated) manufacturer-side to approx. 70 % of the respective maximum torque. The respective torque adjustment or the adjustable torque range are visible on the type tag.

A control “spring operation in the operating range” can be carried out via the dimension “a”.

□ EAS®-Compact® ratchetting and synchronous clutch (Sizes 01 - 3): Dimension “a” is the distance between the adjusting nut facing-side (5) to the thrust washer facing-side (3) (Fig. 5).

□ EAS®-Compact® overload clutch (Sizes 01 - 3): Dimension “a” is the distance between the adjusting nut facing-side (5) to the hub edge (1) (Fig. 6).

For the corresponding data, please see the Installation and Operational Instructions.

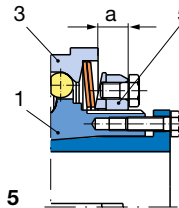

Fig. 5

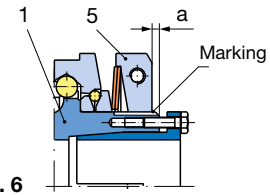

Fig. 6

EAS®-NC Sizes 03 and 02 must be adjusted according to the Adjustment Diagram (please order if necessary) if no adjustment or calibration was made manufacturer-side.

EAS®-NC Size 03 (Fig. 7):

- Unscrew both set screws (8) from the adjusting nut (5).
- Grease the thread surfaces on the adjusting nut (5) and the hub (1).
- Set the adjusting nut (5) to the required dimension “a” (acc. Adjustment Diagram) using a hook wrench.
- Paint both set screws (8) with Loctite 243, screw them into the adjusting nut (5) and tighten them.

EAS®-NC Size 02 (Fig. 8 and Fig. 4):

- Loosen the locking screw (2).
- Grease the thread and contact surfaces on the adjusting nut (5), the locking ring (4) and the hub (1).
- Set the adjusting nut (5) by hand up to contact on the cup spring (9).
- Continue to turn until the four notches on the circumference of the adjusting nut (5) and the notches in the locking ring (4) align.
- Turn the adjusting nut (5) further using a face wrench to the number of graduation lines which equal the required torque (Fig. 4, number of graduation lines in the Adjustment Diagram). The 4 notches on the circumference of the adjusting nut (5) and on the locking ring (4) must be in the same position.
- Paint the locking screw (2) with Loctite 243 and screw it into the adjusting nut (5).

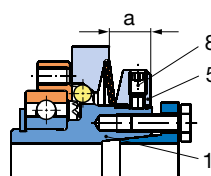

Fig. 7

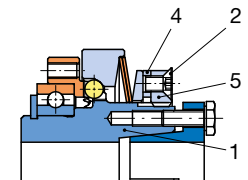

Fig. 8

Technical Explanations

Changing the Torque

Sizes 01 to 3 (Figs. 1, 2 and 6):

- Convert the required torque (acc. formula below) in percent of the maximum adjustment value.

$$\frac{\text{Required torque adjustment}}{\text{Max. torque adjustment (see Table Technical Data)}} \times 100 = \text{Adjustment in \%}$$

- Loosen the locking screw (2) in the adjusting nut (5).
- Turn the adjusting nut (5) clockwise or anti-clockwise according to the engraved adjustment scale (Figs. 1 and 2) using a hook wrench or a face wrench, until the required torque is set.
- The required torque results from:
 - the locking ring (4) marking (D) overlap and the percent value (C) on the adjusting nut (5) (ratchetting and synchronous clutch, Fig. 1), or
 - the hub (1) marking overlap and the percent value on the adjusting nut (5) (overload clutch, Figs. 2 and 6).
- Paint the locking screw (2) with Loctite 243 and screw it into the adjusting nut (5); the 4 notches (A) in the adjusting nut (5) and the notches (B) in the locking ring (4) must be in the same position (Fig. 1). Correct slightly if necessary.

Example:

EAS®-Compact® Size 3, Type 490.610.0 (M_G max. = 350 Nm):
 Torque pre-adjustment = 70 % of M_G max. = 245 Nm.
 The adjustment should be increased from 245 Nm to 280 Nm.

- Define the torque adjustment in percent of M_G max. using the formula below:

$$\frac{280}{350} \times 100 = 80 \%$$

- Turn the adjusting nut (5) according to the facing-side scale (Fig. 1) **anti-clockwise** from 70 % to 80 % on the adjustment scale using a face wrench.

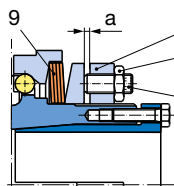

Fig. 9

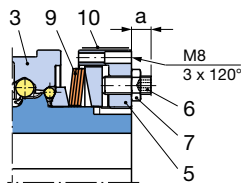

Fig. 10

Sizes 4 and 5 (Figs. 9 and 10):

The torque is changed exclusively via the set screws (6) and not via the adjusting nut (5).

- Loosen all hexagon nuts (7).
- Adjust all set screws (6) evenly to the required dimension "a" using a hexagon socket wrench.
 - EAS®-Compact® ratchetting and synchronous clutch, Size 4: find dimension "a" in the Adjustment Table glued to the clutch (Fig. 9).
 - EAS®-Compact® overload clutch, Sizes 4 - 5: find dimension "a" in the Adjustment Table (10) glued to the adjusting nut (5) (Fig. 10).
- Counter the set screws (6) again using hexagon nuts (7).



After de-installing the clutch (e.g. due to cup spring replacement or changes to the cup spring layering), the clutch must be re-adjusted.

Re-engagement of the EAS®-Compact® overload clutch

EAS®-Compact® overload clutch re-engagement is carried out by applying axial pressure onto the thrust washer (3). It may be necessary to turn between the clutch input and output sides slightly.



Re-engagement must only take place when the device is not running or at low differential speed (< 10 rpm). For a more detailed explanation on re-engagement, please see the respective Installation and Operational Instructions.

Depending on the equipment available, the accessibility of the installation point etc., re-engagement can be carried out in the following ways:

Sizes 01 to 3:

- Manually, e.g. using a plastic hammer or installation levers supported on the adjusting nut (5) (e.g. 2 screwdrivers placed opposite each other).
- By using an engagement mechanism. The engagement procedure can also be automated using pneumatic or hydraulic cylinders.

Sizes 4 and 5:

- By evenly screwing 3 hexagon head screws M8 (provided by the customer) into the adjusting nut (5) (Fig. 10).



After re-engagement has taken place, the three hexagon head screws must be removed immediately, as they could stop the clutch functioning (blockage).

- By using two screwdrivers, applied opposite each other and supported by the cup springs (9).
- By using an engagement mechanism. The engagement procedure can also be automated using pneumatic or hydraulic cylinders.

Permitted Bearing Load

The output element is centred on the deep groove ball bearing (tolerance H7/h5) and bolted together with the pressure flange (3).

If the resulting radial force from the output element is anywhere near the centre of the ball bearing and under the maximum permitted radial load according to Table 1, an additional bearing for the output element is unnecessary.

No appreciable axial forces (see Table 1) should be transferred from the output element onto the clutch pressure flange (3).

Permitted bearing load		Size								
		03	02	01	0	1	2	3	4	5
Axial forces	F_A [kN]	0.12	0.28	0.65	1	1.5	2.4	4.2	5	7.7
Radial forces	F_R [kN]									
1-bearing design		0.1	0.25	0.65	1	1.5	2.4	4.2	5	-
2-bearing design		0.15	0.375	1	1.5	2.25	3.6	6.3	7.5	11.5
Transverse force torques*	M_G [Nm]	0.5	1.5	5	10	20	30	40	50	70

Table 1

* Torques, which put strain on the deep groove ball bearing due to the non-centric axial forces having an effect on the pressure flange.

Technical Explanations

Size Selection, Energy Calculation, Torque Adjustment for Horizontal Servo Axes

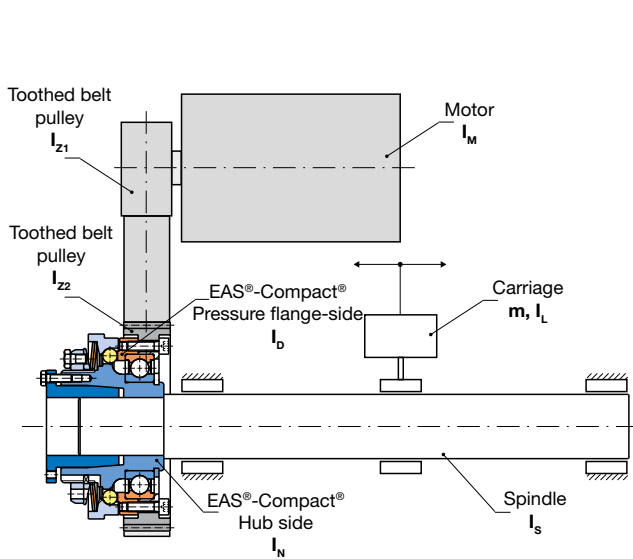

Fig. 1

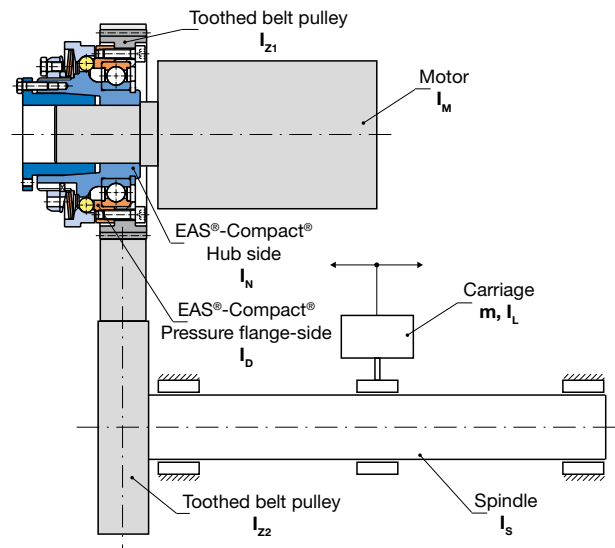

Fig. 2

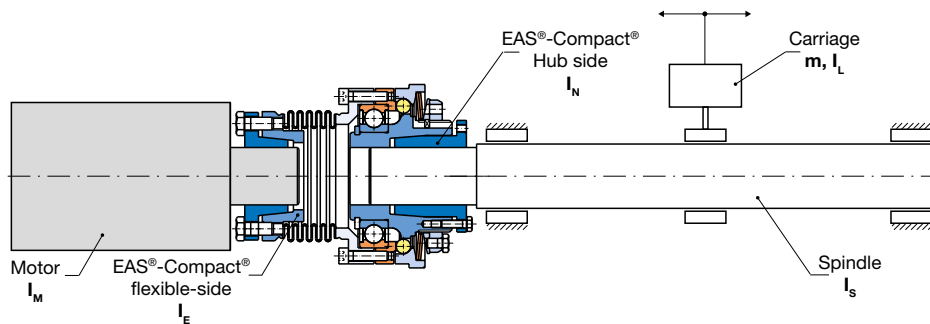
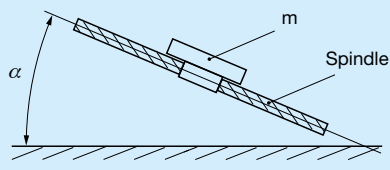

Fig. 3

Configuration Fig. 1	Configuration Fig. 2	Configuration Fig. 3
Total mass moment of inertia without EAS®-Compact® clutch		
$I_g = I_M + I_{z1} + (I_{z2} + I_S + I_L) \cdot \left(\frac{n_2}{n_1}\right)^2$ $I_L \text{ from equation (7)}$	$I_g = I_M + I_{z1} + (I_{z2} + I_S + I_L) \cdot \left(\frac{n_2}{n_1}\right)^2$ $I_L \text{ from equation (7)}$	$I_g = I_M + I_{Ku} + I_S + I_L$ $I_L \text{ from equation (7)}$
Mass moment of inertia input-side referring to the shaft with the EAS®-Compact® clutch		
$I_1 = I_D + I_{z2} + (I_{z1} + I_M) \cdot \left(\frac{n_1}{n_2}\right)^2$	$I_1 = I_M + I_N$	$I_1 = I_M + I_E$
Mass moment of inertia output-side (spindle-side) referring to the shaft with the EAS®-Compact® clutch		
$I_2 = I_N + I_S + I_L$ $I_L \text{ from equation (7)}$	$I_2 = I_D + I_{z1} + (I_{z2} + I_S + I_L) \cdot \left(\frac{n_2}{n_1}\right)^2$ $I_L \text{ from equation (7)}$	$I_2 = I_N + I_S + I_L$ $I_L \text{ from equation (7)}$
Clutch pre-selection		
$M_{\text{erf.}} = 1.5 \cdot M_2$ $M_2 \text{ from equation (4)}$	$M_{\text{erf.}} = 1.5 \cdot M_1$	$M_{\text{erf.}} = 1.5 \cdot M_1$

Configuration Fig. 1	Configuration Fig. 2	Configuration Fig. 3
Torque on the spindle		
$M_2 = M_1 \cdot \frac{n_1}{n_2}$	As configuration Fig. 1	As configuration Fig. 1 [Nm] (4)
Carriage feed rate		
$v = \frac{p \cdot n_2}{6 \cdot 10^4}$	As configuration Fig. 1	As configuration Fig. 1 $\left[\frac{m}{s}\right]$ (5)
Angular speed of the motor shaft ω_1 and the spindle ω_2		
$\omega_1 = \frac{n_1 \cdot \pi}{30}$ $\omega_2 = \frac{n_2 \cdot \pi}{30}$	As configuration Fig. 1	As configuration Fig. 1 $[s^{-1}]$ (6)
Mass of the carriage reduced on the spindle		
$I_L = m \cdot \frac{v^2}{\omega_2^2}$ v from equation (5), ω_2 from equation (6)	As configuration Fig. 1	As configuration Fig. 1 $[kgm^2]$ (7)
Energy on collision without EAS®-Compact® clutch		
$W_g = \frac{1}{2} \cdot I_g \cdot \omega_1^2$ I_g from equation (1), ω_1 from equation (6)	As configuration Fig. 1	As configuration Fig. 1 [J] (8)
Energy on collision with EAS®-Compact® clutch		
$W_2 = \frac{1}{2} \cdot I_2 \cdot \omega_2^2$ I_2 from equation (3), ω_2 from equation (6)	$W_2 = \frac{1}{2} \cdot I_2 \cdot \omega_1^2$ I_2 from equation (3), ω_1 from equation (6)	$W_2 = \frac{1}{2} \cdot I_2 \cdot \omega_1^2$ [J] (9) I_2 from equation (3), ω_1 from eq. (6)
Remaining residual energy		
$W_R = \frac{W_2}{W_g} \cdot 100$ W_g from equation (8), W_2 from equation (9)	As configuration Fig. 1	As configuration Fig. 1 [%] (10)
Uncoupled energy		
$\Delta W = W_g - W_2$	As configuration Fig. 1	As configuration Fig. 1 [J] (11)
$\Delta W = 100 - W_R$ W_g from equation (8), W_2 from equation (9), W_R from equation (10)		As configuration Fig. 1 [%] (12)
Required disengagement torque in the acceleration phase (horizontal axis)		
$M_A = M_B \cdot \frac{I_2}{I_2 + I_1} \cdot \frac{n_1}{n_2}$ I_1 from equation (2), I_2 from equation (3)	Speed ratio $\frac{n_1}{n_2}$ not applicable.	Speed ratio $\frac{n_1}{n_2}$ not applicable. [Nm] (13)
Required disengagement torque in the acceleration phase (axis in any direction)		
$M_A = [(M_B \cdot \frac{n_1}{n_2} - M_L) \cdot \frac{I_2}{I_2 + I_1} + M_L] \times 1.2$ M_L from equation (15)	$M_A = [(M_B - M_L \cdot \frac{n_2}{n_1}) \cdot \frac{I_2}{I_2 + I_1} + M_L \cdot \frac{n_2}{n_1}] \times 1.2$ M_L from equation (15)	$M_A = [(M_B - M_L) \cdot \frac{I_2}{I_2 + I_1} + M_L] \times 1.2$ [Nm] (14) M_L from equation (15)
Load torque from carriage mass in any direction		
$M_L = \frac{m \cdot g \cdot \sin \alpha \cdot p}{2 \cdot \pi \cdot 1000}$ 	As configuration Fig. 1	As configuration Fig. 1 [Nm] (15)
Limit torque adjustment		
$M_G = 1.5 \cdot M_2$ M_2 from equation (4)	$M_G = 1.5 \cdot M_1$	$M_G = 1.5 \cdot M_2$ [Nm] (16) M_2 from equation (4)
Condition: The disengagement torque M_A from equation (13) or (14) (multiplied by a factor of 1.2) must be smaller than the torque M_G set on the clutch.		

Technical Explanations

Calculation Example

Configuration as shown in Fig. 1

Data:

Mass of the carriage	m	=	560 kg
Mass moment of inertia of the motor	I_M	=	0.0037 kgm ²
Mass moment of inertia of the	I_{z1}	=	0.0006 kgm ²
Toothed belt pulleys	I_{z2}	=	0.01132 kgm ²
Mass moment of inertia of the spindle	I_S	=	0.00067 kgm ²
Drive speed of the motor	n_1	=	2000 rp
Speed of the spindle	n_2	=	1000 rpm
Pitch of the spindle	p	=	10 mm
Nominal torque of the motor	M_1	=	14 Nm
Max. torque of the motor	M_B	=	40 Nm

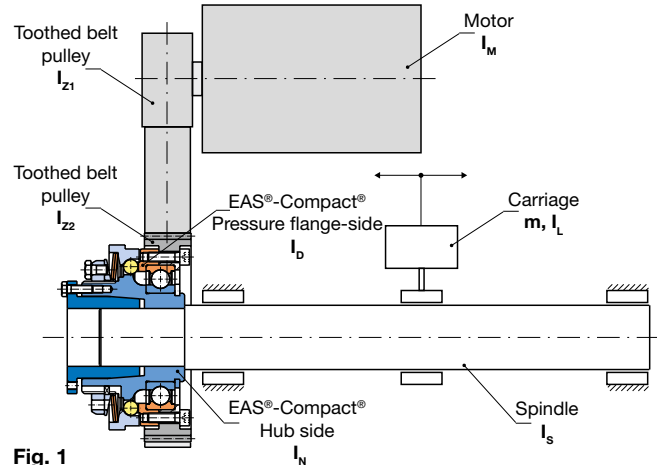

Fig. 1

Clutch pre-selection

$$M_{\text{erf.}} = 1.5 \cdot M_2 \quad M_{\text{erf.}} = 1.5 \cdot 28 = 42 \quad [\text{Nm}]$$

Selected: EAS®-Compact® Size 0, Type 490.610.0
Torque range $M_G = 20 \div 50 \text{ Nm}$
(see Technical Data, page 9)

Total mass moment of inertia of the EAS®-Compact®

Hub side $I_N = 0.000531 \text{ kgm}^2$ (see Techn. Data, page 9)
Pressure flange side $I_D = 0.000234 \text{ kgm}^2$ (see Techn. Data, page 9)

Total mass moment of inertia without EAS®-Compact® clutch

$$I_g = I_M + I_{z1} + (I_{z2} + I_S + I_L) \cdot \left(\frac{n_2}{n_1}\right)^2 \quad I_L \text{ from equation (7)}$$

$$I_g = 0.0037 + 0.0006 + (0.01132 + 0.00067 + 0.00142) \cdot \left(\frac{1000}{2000}\right)^2$$

$$I_g = 0.00765 \quad [\text{kgm}^2] \quad (1)$$

Mass moment of inertia input-side referring to the shaft with the EAS®-Compact® clutch

$$I_1 = I_D + I_{z2} + (I_{z1} + I_M) \cdot \left(\frac{n_1}{n_2}\right)^2$$

$$I_1 = 0.000234 + 0.01132 + (0.0006 + 0.0037) \cdot \left(\frac{2000}{1000}\right)^2$$

$$I_1 = 0.0287 \quad [\text{kgm}^2] \quad (2)$$

Mass moment of inertia output-side (spindle-side) referring to the shaft with the EAS®-Compact® clutch

$$I_2 = I_N + I_S + I_L \quad I_L \text{ from equation (7)}$$

$$I_2 = 0.000531 + 0.00067 + 0.00142 = 0.00262 \quad [\text{kgm}^2] \quad (3)$$

Torque on the spindle

$$M_2 = M_1 \cdot \frac{n_1}{n_2} = 14 \cdot \frac{2000}{1000} = 28 \quad [\text{Nm}] \quad (4)$$

Carriage feed rate

$$v = \frac{p \cdot n_2}{6 \cdot 10^4} = \frac{10 \cdot 1000}{6 \cdot 10^4} = 0.1667 \quad \left[\frac{\text{m}}{\text{s}}\right] \quad (5)$$

Angular speed of the motor shaft ω_1 and the spindle ω_2

$$\omega_1 = \frac{n_1 \cdot \pi}{30} = \frac{2000 \cdot \pi}{30} = 209 \quad [\text{s}^{-1}] \quad (6)$$

$$\omega_2 = \frac{n_2 \cdot \pi}{30} = \frac{1000 \cdot \pi}{30} = 104.7 \quad [\text{s}^{-1}] \quad (6)$$

Mass of the carriage reduced on the spindle

$$I_L = m \cdot \frac{v^2}{\omega_2^2} = 560 \cdot \frac{0.1667^2}{104.7^2} = 0.00142 \quad [\text{kgm}^2] \quad (7)$$

v from equation (5), ω_2 from equation (6)

Energy on collision without EAS®-Compact® clutch

$$W_g = \frac{1}{2} \cdot I_g \cdot \omega_1^2 = \frac{1}{2} \cdot 0.00765 \cdot 209^2 = 167 \quad [\text{J}] \quad (8)$$

I_g from equation (1), ω_1 from equation (6)

Energy on collision with EAS®-Compact® clutch

$$W_2 = \frac{1}{2} \cdot I_2 \cdot \omega_2^2 = \frac{1}{2} \cdot 0.00262 \cdot 104.7^2 = 14 \quad [\text{J}] \quad (9)$$

I_2 from equation (3), ω_2 from equation (6)

Remaining residual energy

$$W_R = \frac{W_2}{W_g} \cdot 100 = \frac{14}{167} \cdot 100 = 8.4 \quad [\%] \quad (10)$$

W_g from equation (8), W_2 from equation (9)

Uncoupled energy

$$\Delta W = W_g - W_2 = 167 - 14 = 153 \quad [\text{J}] \quad (11)$$

$$\Delta W = 100 - W_R = 100 - 8.4 = 91.6 \quad [\%] \quad (12)$$

Required disengagement torque in the acceleration phase (horizontal axis)

$$M_A = M_B \cdot \frac{I_2}{I_2 + I_1} \cdot \frac{n_1}{n_2} \quad I_1 \text{ from equation (2)}$$

$$M_A = 40 \cdot \frac{0.00262}{0.00262 + 0.0287} \cdot \frac{2000}{1000} = 6.7 \quad [\text{Nm}] \quad (13)$$

Limit torque adjustment

$$M_G = 1.5 \cdot M_2 = 1.5 \cdot 28 = 42 \quad [\text{Nm}] \quad (16)$$

Condition: The disengagement torque $1.2 \cdot M_A = 1.2 \cdot 6.7 = 8.04 \text{ Nm}$ is smaller than the torque $M_G = 42 \text{ Nm}$ set on the clutch.

Technical Explanations

Keys

I_g	[kgm ²]	Total mass moment of inertia without EAS [®] -Compact [®] clutch
I_1	[kgm ²]	Mass moment of inertia input-side referring to the shaft with the EAS [®] -Compact [®] clutch
I_2	[kgm ²]	Mass moment of inertia output-side (spindle-side) referring to the shaft with the EAS [®] -Compact [®] clutch
I_M	[kgm ²]	Mass moment of inertia of the motor
I_{Z1}	[kgm ²]	Mass moment of inertia of the motor-side toothed belt pulley
I_{Z2}	[kgm ²]	Mass moment of inertia of the second toothed belt pulley
I_S	[kgm ²]	Mass moment of inertia of the spindle
I_L	[kgm ²]	Mass of the carriage reduced on the spindle
I_N	[kgm ²]	Mass moment of inertia of the EAS [®] -Compact [®] , hub-side
I_D	[kgm ²]	Mass moment of inertia of the EAS [®] -Compact [®] , pressure flange-side
I_E	[kgm ²]	Mass moment of inertia of the EAS [®] -Compact [®] , flexible coupling
I_{Ku}	[kgm ²]	Mass moment of inertia of the double shaft connection before installation of the EAS [®] -Compact [®] clutch
M_1	[Nm]	Motor nominal torque
M_2	[Nm]	Torque on the spindle
M_A	[Nm]	Required disengagement torque in the acceleration phase
M_B	[Nm]	Maximum motor torque
M_G	[Nm]	Limit torques for overload
M_L	[Nm]	Load torque from the carriage mass in any direction
$M_{erf.}$	[Nm]	Required torque (pre-selection of the clutch)
g	[m·s ⁻²]	Gravitational acceleration
m	[kg]	Carriage mass
n_1	[rpm]	Drive speed on the motor (rapid movement)
n_2	[rpm]	Spindle speed (rapid movement)
p	[mm]	Spindle pitch
v	[m·s ⁻¹]	Carriage feed rate
W_g	[J]	Total energy on collision without EAS [®] -Compact [®] clutch
W_2	[J]	Energy on collision with EAS [®] -Compact [®] clutch
W_R	[%]	Remaining residual energy
ΔW	[J]	Uncoupled energy
ΔW	[%]	Uncoupled energy
ω_1	[s ⁻¹]	Angular speed of the motor shaft
ω_2	[s ⁻¹]	Angular speed of the spindle

Frictionally-locking Transmittable Torques

Table 1: Assignment of the bore diameters d_3/d_4 on the flexible coupling to the transmittable torque “ T_R ” EAS®-Compact® synchronous, ratchetting and overload clutches Types 494_0_./494_1_.

		Bore	Size						
			01	0	1	2	3	4	
Frictionally-locking transmittable torques	T_R [Nm]	Ø 15	d_3	34	-	-	-	-	-
			d_4	56	-	-	-	-	-
		Ø 16	d_3	36	-	-	-	-	-
			d_4	62	-	-	-	-	-
		Ø 19	d_3	43	79	-	-	-	-
			d_4	81	141	-	-	-	-
		Ø 20	d_3	45	83	83	-	-	-
			d_4	87	153	197	-	-	-
		Ø 22	d_3	50	91	91	-	-	-
			d_4	100	177	228	-	-	-
		Ø 24	d_3	54	100	100	-	-	-
			d_4	120	203	261	-	-	-
		Ø 25	d_3	57	104	104	-	-	-
			d_4	125	216	279	-	-	-
		Ø 28	d_3	63	116	116	208	-	-
			d_4	135	256	332	300	-	-
		Ø 30	d_3	-	124	124	228	-	-
			d_4	-	282	368	350	-	-
		Ø 32	d_3	-	133	133	248	-	-
			d_4	-	308	405	400	-	-
		Ø 35	d_3	-	145	145	280	350	-
			d_4	-	343	460	500	450	-
		Ø 38	d_3	-	-	158	315	390	-
			d_4	-	-	373	600	500	-
		Ø 40	d_3	-	-	166	340	420	-
			d_4	-	-	547	680	600	-
		Ø 42	d_3	-	-	174	365	455	-
			d_4	-	-	577	730	720	-
		Ø 45	d_3	-	-	187	404	505	545
			d_4	-	-	617	790	850	1402
		Ø 48	d_3	-	-	-	442	560	590
			d_4	-	-	-	850	1000	1596
		Ø 50	d_3	-	-	-	470	600	630
			d_4	-	-	-	880	1180	1731
		Ø 52	d_3	-	-	-	-	640	662
			d_4	-	-	-	-	1270	1873
		Ø 55	d_3	-	-	-	-	705	710
			d_4	-	-	-	-	1353	2095
		Ø 58	d_3	-	-	-	-	-	764
			d_4	-	-	-	-	1428	2308
Ø 60	d_3	-	-	-	-	-	800		
	d_4	-	-	-	-	1471	2420		
Ø 62	d_3	-	-	-	-	-	840		
	d_4	-	-	-	-	-	2570		
Ø 65	d_3	-	-	-	-	-	900		
	d_4	-	-	-	-	-	2750		
Ø 68	d_3	-	-	-	-	-	954		
	d_4	-	-	-	-	-	2989		
Ø 70	d_3	-	-	-	-	-	990		
	d_4	-	-	-	-	-	3157		
Ø 72	d_3	-	-	-	-	-	1032		
	d_4	-	-	-	-	-	3306		
Ø 75	d_3	-	-	-	-	-	1095		
	d_4	-	-	-	-	-	3550		
Ø 78	d_3	-	-	-	-	-	1158		
	d_4	-	-	-	-	-	-		
Ø 80	d_3	-	-	-	-	-	1200		
	d_4	-	-	-	-	-	-		

Frictionally-locking transmittable torques

Clamping hub Ø d_3
Valid for F7/k6

Shrink disk hub Ø d_4
Valid for H7/k6

The transmittable torques of the clamping connection take the max. tolerance backlash of the shaft tolerance k6/ bores F7 or H7 into account.

If the tolerance backlash is larger, the torque decreases.

Limit Switch Type 055.00_5 (Contactless)

Application

This device is used for measuring and monitoring axial and radial disengagement movements, e.g. on EAS®-clutches. It acts as a control sensor for electronic and mechanical sequences.

Function

When the sensor surface of the NAMUR sensor scans a metal control flag (damped), the signalling relay is triggered, is deenergised and drops. Contacts 1 - 2 are opened. Damping is possible from all sides.

Electrical Connection (Terminals)

- 1 – 2 – 3 Floating change-over contacts
- 5 – 6 Connection input voltage

Design

The electronic amplifier is installed in a light metal housing. The limit switch is fixed using two screw-on mounting links attached diagonally with M4 cap screws.

Technical Data

Input voltage	230 VAC, ±10 %, 50 – 60 Hz
(dependent on design)	115 VAC, ±10 %, 50 – 60 Hz
	24 VDC, PELV, ±5 %, protected against reverse polarity, for overvoltage category II connection
Power consumption	Max. 1.5 VA
Ambient temperature	-10 °C up to +60 °C limit switch
	-25 °C up to +60 °C NAMUR sensor
Protection	IP54
Conductor cross-section	Max. 2.5 mm ² / AWG 14
Weight	400 g / 14 oz
Protection fuse	0.1 A/fast acting at 24 VDC (in system)
Signalling relay	Floating change-over contacts
	Contact load max. 250 VAC / 12 A
	Contact material AgNi 90/10
	max. switching frequency 20 Hz at min. load, 0.1 Hz at max. load
NAMUR sensor internal	Installed in a light metal housing, switching distance S_n 2 mm, flush fitting, max. switching frequency 2 kHz, the zero point can be set per 1 mm by means of the lateral adjusting screw SW 7
NAMUR sensor external	Metal housing M12 x 1, switching distance S_n 2 mm, flush fitting, max. switching frequency 2 kHz, standard cable length 2 m, max. 100 m on special design, protection IP67

Installation

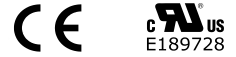
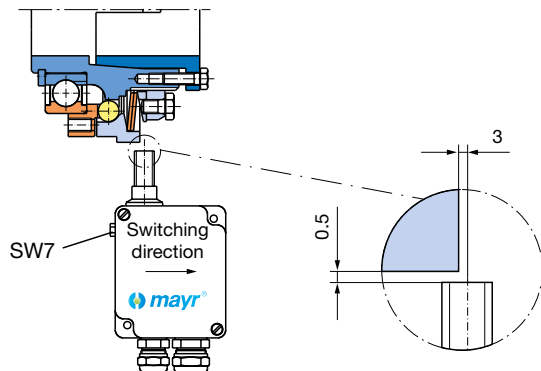

Dimensions (internal NAMUR sensor)

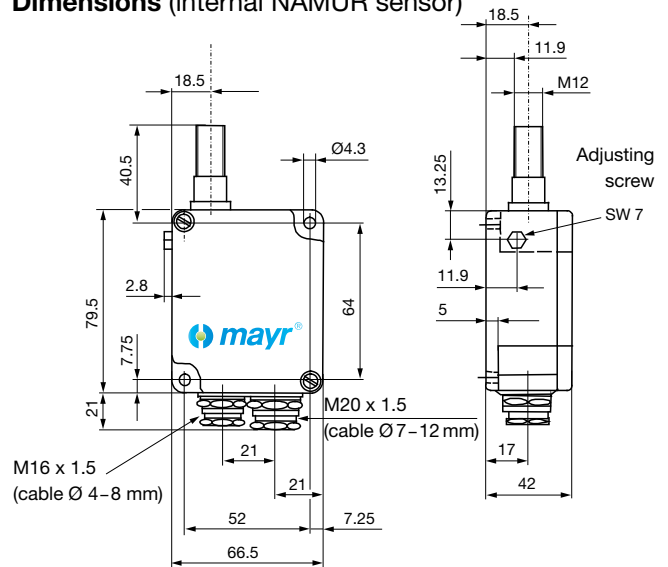

Dimensions (external NAMUR sensor)

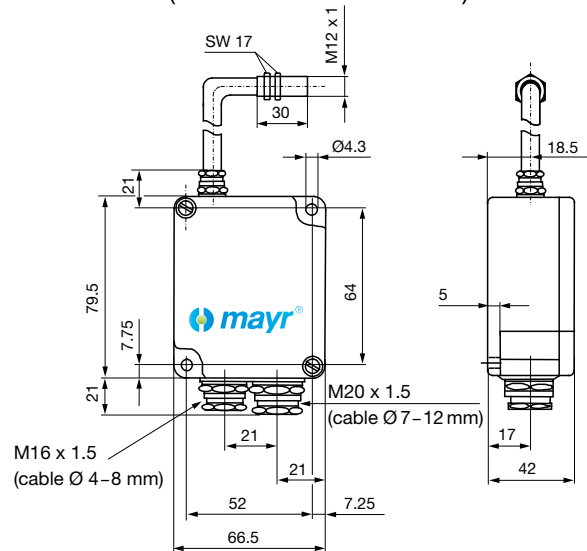

Order Number

0 5 5 . 0 0 _ . 5 / _

Contactless sensing		Connection voltage	
Sensor external	1	230 VAC	
Sensor internal	2	115 VAC	
		24 VDC	

Limit Switch Type 055.000.5 (Mechanical Operation)



Application

This device is used to monitor mechanical movements and end positions. It is a controlling sensor for electronic and mechanical sequences. It also detects axial disengagement movements, e.g. on EAS[®]-clutches.

Function

The pre-tensioned contact is discharged by actuating the switching lever:
Contacts 11 – 14 (21 – 24) open, contacts 11 – 12 (21 – 22) close.

Design

The microswitch is fitted into a light metal housing and is actuated by a switching lever. Operation is only possible in one direction. The limit switch is fixed using two screw-on mounting links attached diagonally with M4 cap screws.



Technical Data

Contact	1 change-over contact (special design: 2 change-over contacts)
Switching power	250 VAC / 15 A (with 2 change-over contacts: 10 A) 24 VDC / 6 A 60 VDC / 1.5 A 250 VDC / 0.2 A min. 12 VDC / 10 mA
Contact material	AgSnO
Switching frequency	Max. 200 switching operations/min
Ambient temperature:	-10 °C up to +85 °C
Protection	IP54
Weight	275 g
Switching travel setting	Using the adjusting screw (SW 7), the zero point can be moved right or left by max. 5 mm
Switching travel	Pretravel: min. 0.15 to 0.5 mm Overtravel: max. 10 mm, depending on the zero point setting
Special types	Different switching lever lengths as well as a design with 2 change-over contacts are possible on request

Dimensions

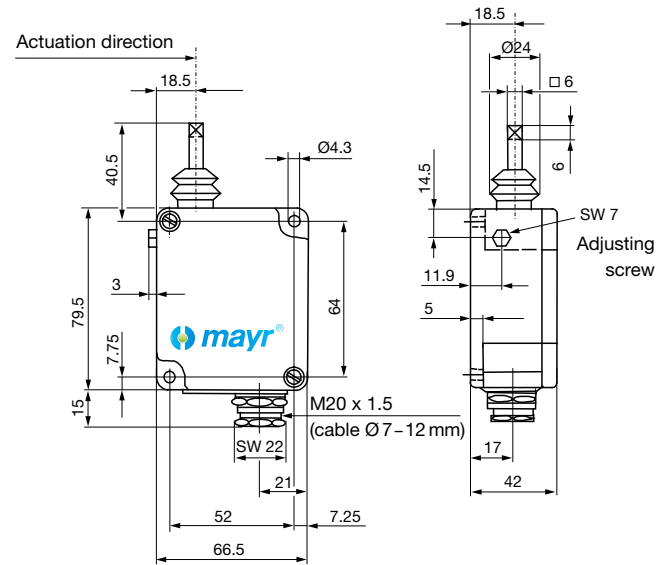

Installation

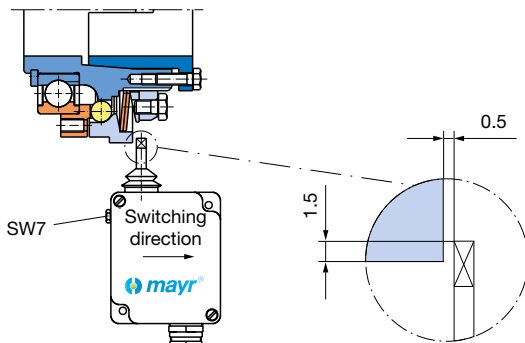

Electrical Connection

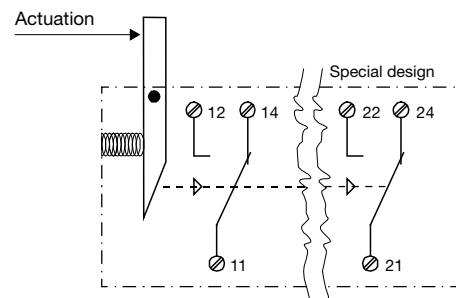

Order Number

0 5 5 . 0 0 0 . 5

Limit Switch Type 055.010.6 (Mechanical Operation, Multi-directional)

Application

The limit switch is used to monitor and measure axial or radial mechanical movements and adjustments e.g. on EAS®-clutches. The device is suitable for clutches with a minimum stroke of 1.1 mm with radial actuation and 0.9 mm with axial actuation.

Function

By actuating the metal tappet, contacts 11 – 12 are opened.

Electrical Connection (Terminals)

11 – 12 NC contact

Technical Data

Contact	1 x NC contact, positive opening contacts ☺
Contact (Special Design)	additional 1 x NO contact, terminals 23 – 24, galvanically separated (Zb)
Contact-opening	see Switching Travel Diagram
Contact-closing	see Switching Travel Diagram
Contact-load	NC contact 250 VAC / 2.5 A 24 VDC / 1 A min. 12 VDC / 10 mA
Contact distance 250 VAC	>1.25 mm axial, forced opening
Contact distance 24 VDC	<1.25 mm, min. 0.5 mm
Contact material	Ag90Ni10
Max. input current	acc. DIN EN 60947-5-1 AC15 / DC13
Metal tappet travel	max. 4 mm axial or radial
Switching frequency	max. 100/min.
Mechanical lifetime	1 x 10 ⁶ switching cycles, unloaded
Conductor cross-section	1.5 mm ² / AWG 16
Ambient temperature:	-30 °C up to +80 °C
Protection	IP65
Protection insulation	acc. Protection Class II ☐
Housing	thermoplastic, self extinguishing acc. UL94-V0
Weight	120 g / 4.2 oz



Dimensions

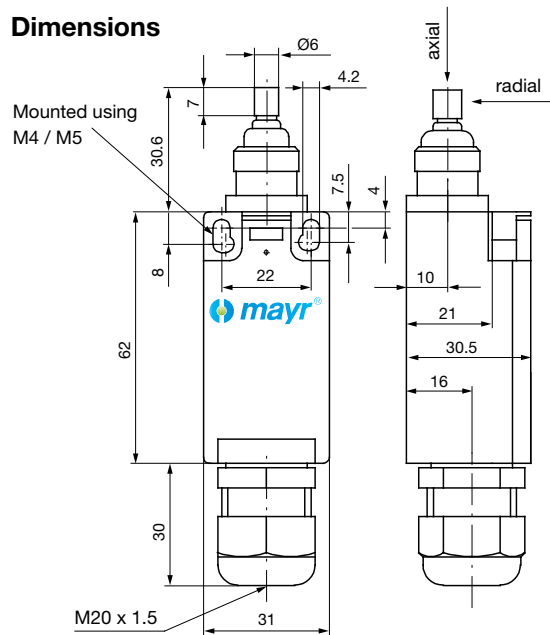

Fixed positioning for safety application with fixing screws
2 x M5 (DIN 912).

Installation

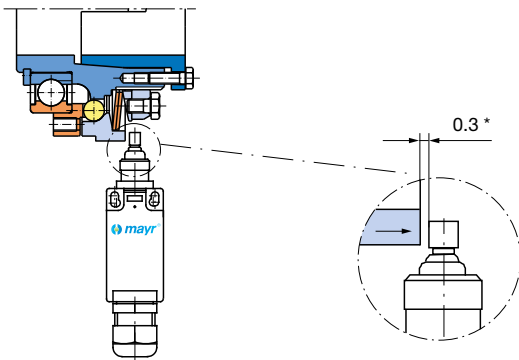

* Switch distance on engaged clutch

Switching Travel Diagram

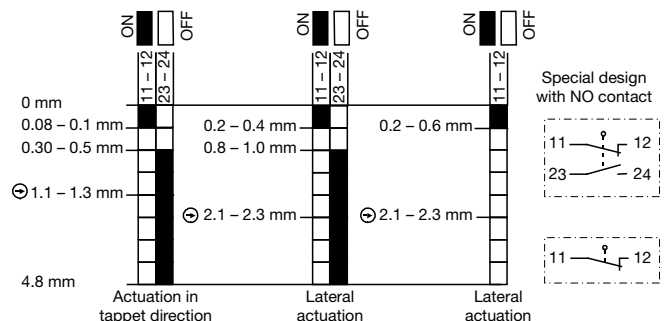

Do not install switch so that it drags and observe max. actuation travel (travel of metal tappet).

Order Number

0 5 5 . 0 1 0 . 6

Installation Examples

EAS®-Compact® short hub

The drive elements of the EAS®-Compact® short hub are centred on the deep groove ball bearing and are screwed together with the pressure flange. If the resulting radial force from the drive element is anywhere near the centre of the ball bearing, an additional bearing for the drive element is unnecessary.



The screw quality and the tightening torque for the fixing screws of the drive element are to be selected so that the set limit torque can be safely transmitted using frictional locking.

Fig. 1

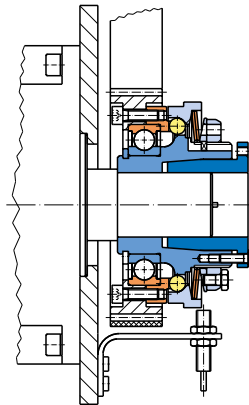

EAS®-Compact® long protruding hub

The EAS®-Compact® long protruding hub is recommended for very wide drive elements or for elements with very small diameters. On a small diameter, the drive element is screwed together via a customer-side intermediate flange with the clutch pressure flange. Ball bearings, needle bearings or plain bearings are suitable as bearings for the drive element, depending on the installation situation and the installation space.

Fig. 2

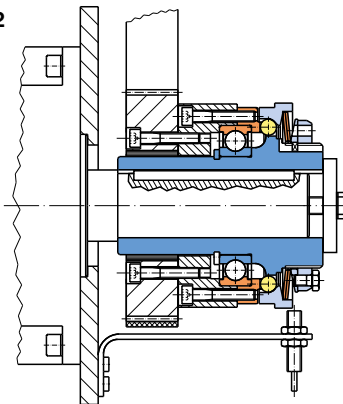

EAS®-Compact® with flexible shaft coupling

The EAS®-Compact® with a backlash-free, torsionally flexible and vibration-damping shaft coupling for the connection of two shafts. The coupling compensates for axial, radial and angular shaft misalignments. In comparison to the EAS®-Compact® with steel bellows coupling, this product is torsionally flexible to a small extent in the circumferential direction.

In the installation example on the right, the EAS®-Compact® lastic is mounted backlash-free between the rotor and a ball screw spindle. The torque is transmitted backlash-free up to the point of disengagement and drops immediately on overload. The contactless limit switch (sensor) emits a signal to switch off the drive.

Fig. 3

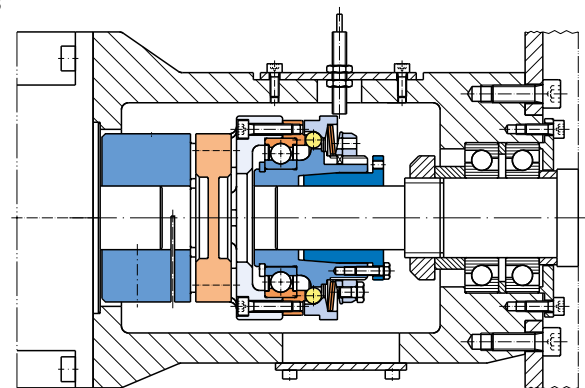

EAS®-Compact® with steel bellows coupling

The EAS®-Compact® with a torsionally rigid flexible steel bellows coupling for the connection of two shafts. The coupling compensates for axial, radial and angular shaft misalignments. It is torsionally rigid in the circumferential direction.

In comparison to the EAS®-Compact® with ROBA®-D coupling, the EAS®-Compact® with steel bellows coupling has a lower mass moment of inertia.

In the installation example on the right, the EAS®-Compact® with steel bellows coupling is mounted between the rotor and a ball screw spindle. The torque is transmitted backlash-free up to the point of disengagement and drops immediately on overload. The contactless limit switch (sensor) emits a signal to switch off the drive.

Fig. 4

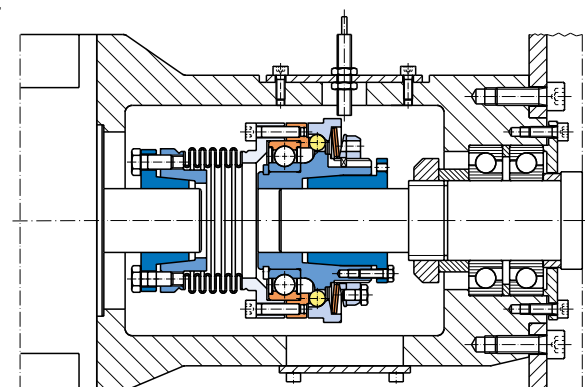

Product Summary

Safety Clutches/Overload Clutches

- ❑ **EAS®-Compact®/EAS®-NC**
Positive locking and completely backlash-free torque limiting clutches
- ❑ **EAS®-smartic®**
Cost-effective torque limiting clutches, quick installation
- ❑ **EAS®-element clutch/EAS®-elements**
Load-disconnecting protection against high torques
- ❑ **EAS®-axial**
Exact limitation of tensile and compressive forces
- ❑ **EAS®-Sp/EAS®-Sm/EAS®-Zr**
Load-disconnecting torque limiting clutches with switching function
- ❑ **ROBA®-slip hub**
Load-holding, frictionally locked torque limiting clutches
- ❑ **ROBA®-contitorque**
Magnetic continuous slip clutches
- ❑ **EAS®-HSC/EAS®-HSE**
High-speed safety clutches for high-speed applications

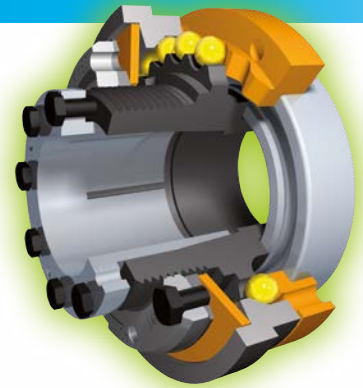

Shaft Couplings

- ❑ **smartflex®/primeflex®**
Perfect precision couplings for servo and stepping motors
- ❑ **ROBA®-ES**
Backlash-free and damping for vibration-sensitive drives
- ❑ **ROBA®-DS/ROBA®-D**
Backlash-free, torsionally rigid all-steel couplings
- ❑ **ROBA®-DSM**
Cost-effective torque-measuring couplings

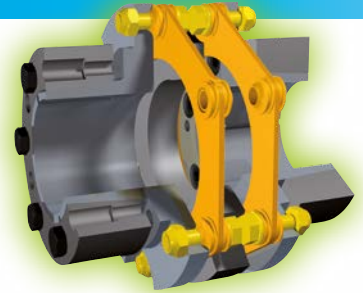

Electromagnetic Brakes/Clutches

- ❑ **ROBA-stop® standard**
Multifunctional all-round safety brakes
- ❑ **ROBA-stop®-M Motor brakes**
Robust, cost-effective motor brakes
- ❑ **ROBA-stop®-S**
Water-proof, robust monoblock brakes
- ❑ **ROBA-stop®-Z/ROBA-stop®-silenzio®**
Doubly safe elevator brakes
- ❑ **ROBA®-diskstop®**
Compact, very quiet disk brakes
- ❑ **ROBA®-topstop®**
Brake systems for gravity loaded axes
- ❑ **ROBA®-linearstop**
Backlash-free brake systems for linear motor axes
- ❑ **ROBA®-guidestop**
Backlash-free holding brake for profiled rail guides
- ❑ **ROBATIC®/ROBA®-quick/ROBA®-takt**
Electromagnetic clutches and brakes, clutch brake units



DC Drives

- ❑ **tendo®-PM**
Permanent magnet-excited DC motors

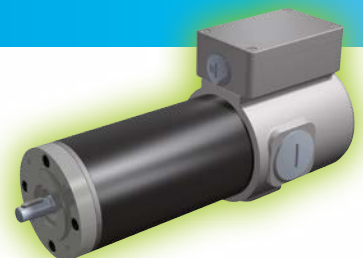

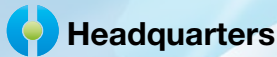

Headquarters

Chr. Mayr GmbH + Co. KG
Eichenstraße 1, D-87665 Mauerstetten
Tel.: +49 83 41/8 04-0, Fax: +49 83 41/80 44 21
www.mayr.com, E-Mail: info@mayr.com



your reliable partner

Service Germany

Baden-Württemberg

Esslinger Straße 7
 70771 Leinfelden-Echterdingen
 Tel.: 07 11/45 96 01 0
 Fax: 07 11/45 96 01 10

Bavaria

Eichenstraße 1
 87665 Mauerstetten
 Tel.: 0 83 41/80 41 04
 Fax: 0 83 41/80 44 23

Chemnitz

Bornaer Straße 205
 09114 Chemnitz
 Tel.: 03 71/4 74 18 96
 Fax: 03 71/4 74 18 95

Franken

Unterer Markt 9
 91217 Hersbruck
 Tel.: 0 91 51/81 48 64
 Fax: 0 91 51/81 62 45

Hagen

Im Langenstück 6
 58093 Hagen
 Tel.: 0 23 31/78 03 0
 Fax: 0 23 31/78 03 25

Kamen

Lünener Straße 211
 59174 Kamen
 Tel.: 0 23 07/23 63 85
 Fax: 0 23 07/24 26 74

North

Schiefer Brink 8
 32699 Extertal
 Tel.: 0 57 54/9 20 77
 Fax: 0 57 54/9 20 78

Rhine-Main

Hans-Böckler-Straße 6
 64823 Groß-Umstadt
 Tel.: 0 60 78/7 82 53 37
 Fax: 0 60 78/9 30 08 00

Branch office

China

Mayr Zhangjiagang
 Power Transmission Co., Ltd.
 Chenxin Road No.7,
 215637 Zhangjiagang
 Tel.: 05 12/58 91-75 67
 Fax: 05 12/58 91-75 66
 info@mayr-ptc.cn

Great Britain

Mayr Transmissions Ltd.
 Valley Road, Business Park
 Keighley, BD21 4LZ
 West Yorkshire
 Tel.: 0 15 35/66 39 00
 Fax: 0 15 35/66 32 61
 sales@mayr.co.uk

France

Mayr France S.A.S.
 Z.A.L. du Minopole
 Rue Nungesser et Coli
 62160 Bully-Les-Mines
 Tel.: 03.21.72.91.91
 Fax: 03.21.29.71.77
 contact@mayr.fr

Italy

Mayr Italia S.r.l.
 Viale Veneto, 3
 35020 Saonara (PD)
 Tel.: 0498/79 10 20
 Fax: 0498/79 10 22
 info@mayr-italia.it

Singapore

Mayr Transmission (S) PTE Ltd.
 No. 8 Boon Lay Way Unit 03-06,
 TradeHub 21
 Singapore 609964
 Tel.: 00 65/65 60 12 30
 Fax: 00 65/65 60 10 00
 info@mayr.com.sg

Switzerland

Mayr Kupplungen AG
 Tobelackerstraße 11
 8212 Neuhausen am Rheinfall
 Tel.: 0 52/6 74 08 70
 Fax: 0 52/6 74 08 75
 info@mayr.ch

USA

Mayr Corporation
 4 North Street
 Waldwick
 NJ 07463
 Tel.: 2 01/4 45-72 10
 Fax: 2 01/4 45-80 19
 info@mayrcorp.com

Representatives

Australia

Regal Beloit Australia Pty Ltd.
 19 Corporate Ave
 03178 Rowville, Victoria
 Australien
 Tel.: 0 3/92 37 40 00
 Fax: 0 3/92 37 40 80
 salesAUvic@regalbeloit.com

India

National Engineering
 Company (NENCO)
 J-225, M.I.D.C.
 Bhosari Pune 411026
 Tel.: 0 20/27 13 00 29
 Fax: 0 20/27 13 02 29
 nenco@nenco.org

Japan

MATSUI Corporation
 2-4-7 Azabudai
 Minato-ku
 Tokyo 106-8641
 Tel.: 03/35 86-41 41
 Fax: 03/32 24 24 10
 k.goto@matsui-corp.co.jp

Netherlands

Groneman BV
 Amarilstraat 11
 7554 TV Hengelo OV
 Tel.: 074/2 55 11 40
 Fax: 074/2 55 11 09
 aandrijftechnik@groneman.nl

Poland

Wamex Sp. z o.o.
 ul. Pozaryskiego, 28
 04-703 Warszawa
 Tel.: 0 22/6 15 90 80
 Fax: 0 22/8 15 61 80
 wamex@wamex.com.pl

South Korea

Mayr Korea Co. Ltd.
 15, Yeondeok-ro 9beon-gil
 Seongsan-gu
 51571 Changwon-si
 Gyeongsangnam-do, Korea
 Tel.: 0 55/2 62-40 24
 Fax: 0 55/2 62-40 25
 info@mayrkorea.com

Taiwan

German Tech Auto Co., Ltd.
 No. 28, Fenggong Zhong Road,
 Shengang Dist.,
 Taichung City 429, Taiwan R.O.C.
 Tel.: 04/25 15 05 66
 Fax: 04/25 15 24 13
 abby@zfgta.com.tw

Czech Republic

BMC - TECH s.r.o.
 Hvězdoslavova 29 b
 62700 Brno
 Tel.: 05/45 22 60 47
 Fax: 05/45 22 60 48
 info@bmc-tech.cz

More representatives:

Austria, Belgium, Brazil, Canada, Denmark, Finland, Greece, Hongkong, Hungary, Indonesia, Israel, Luxembourg, Malaysia, New Zealand, Norway, Philippines, Romania, Russia, Slovakia, Slovenia, South Africa, Spain, Sweden, Thailand, Turkey

You can find the complete address for the representative responsible for your area under www.mayr.com in the internet.