

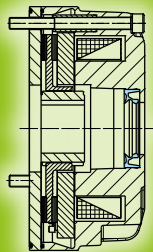

your reliable partner

ROBA-stop®-M

Electromagnetic
safety brakes

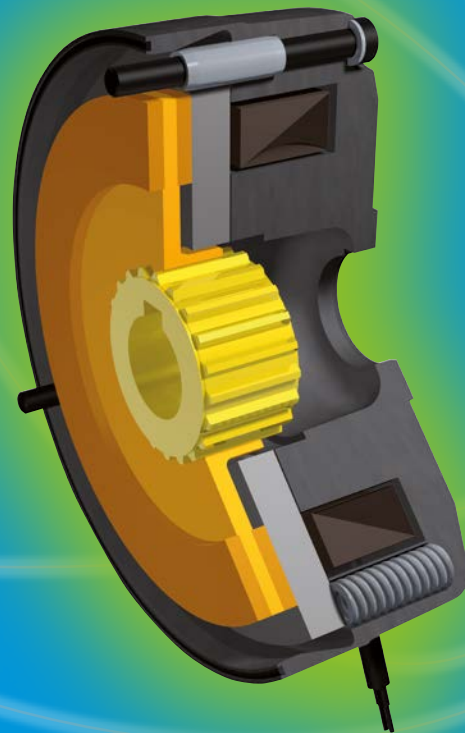

Your Reliable Brake

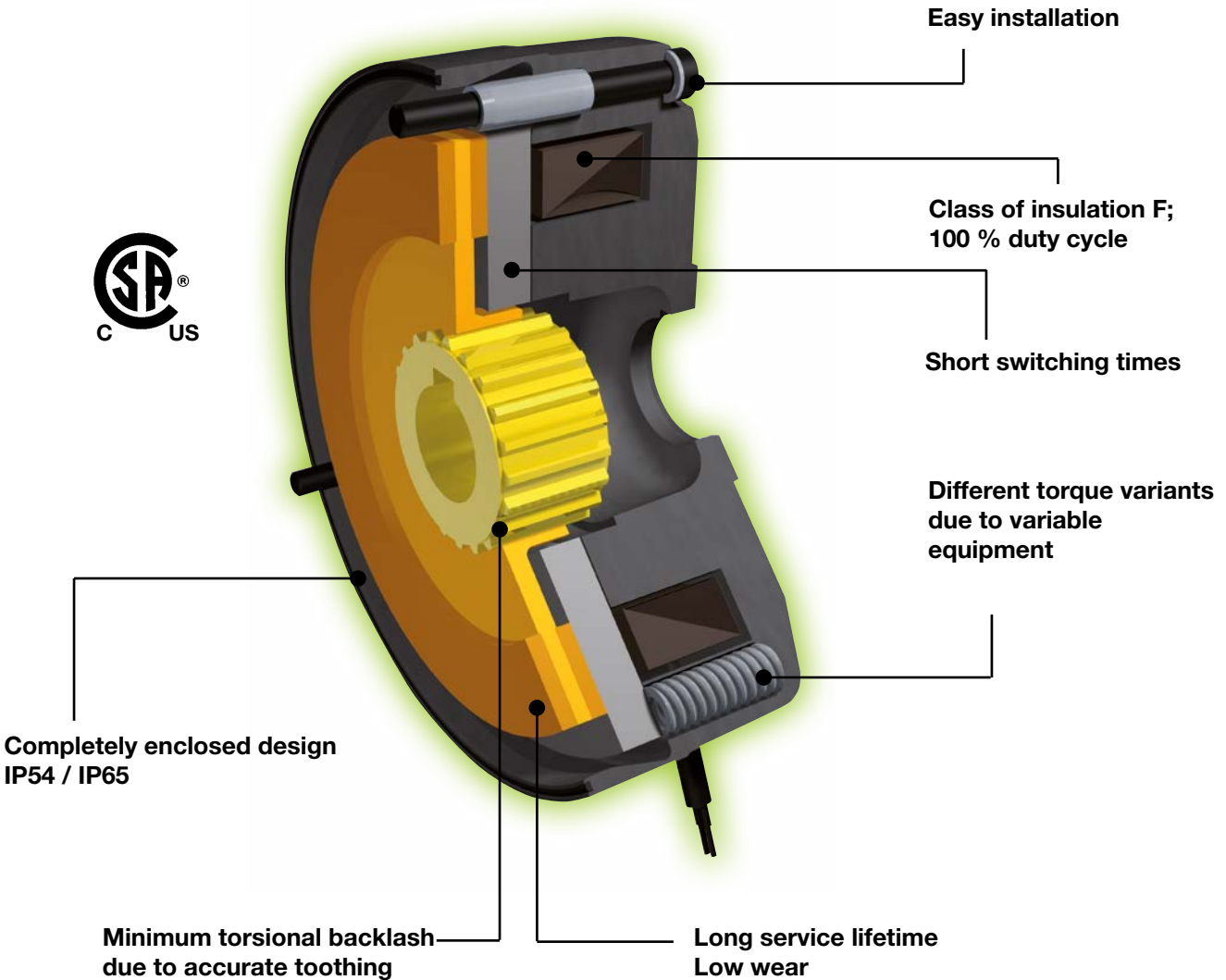

Advantages for Your Applications

- Simple installation
- Brake outer diameter completely enclosed (higher protection can easily be realised)
- Magnetic coil is designed for a relative duty cycle of 100 %
- Magnetic coil and casting compound correspond to class of insulation F
- The nominal air gap is specified by design and inspected
- Short switching times
- Maintenance-free over the entire service lifetime of the rotor

Function

ROBA-stop[®]-M brakes are spring applied, electromagnetic safety brakes.

Spring applied function:

In de-energised condition, helical springs (6) press against the armature disk (5). The rotor (3) is held between the armature disk (5) and the corresponding mounting surface of the machine. The shaft is braked via the toothed hub (1).

Electromagnetic:

When the power is switched on, a magnetic field is built up. The armature disk (5) is attracted to the coil carrier (2) against the spring pressure. The brake is released and the shaft is able to rotate freely.

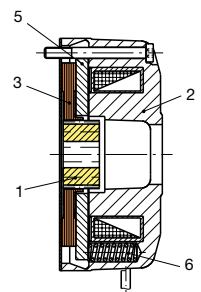

Safety brakes:

The brake brakes reliably and safely in the event of a power switch-off, a power failure or an EMERGENCY STOP.



Certain ROBA-stop[®]-M brakes can be used for safety-relevant applications acc. ISO 13849-1 (for Permitted Types, see page 26). For information on the safety parameters, please contact *mayr*[®] power transmission.

ROBA-stop®-M Page 4 ▷

Sizes 2 to 1000

Braking torques

0.7 to 1400 Nm
(Standard design)

4 to 1600 Nm
(Holding brake)

Permitted shaft diameter

Ø 8 to 90

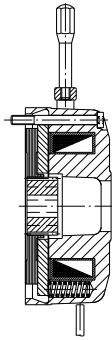

Type 891._.1.0 Standard design

Page 5 ▷

Type 891._.2.0 Standard design with friction disk

Type 891._.4.1 IP65 design with flange plate

Type 891._.4.2 Tacho attachment design with flange plate

Short Description Installation Page 6 ▷

Brake Dimensioning, Friction-Power Diagrams Page 8 ▷

Further Options Page 10 ▷

Switching Times, Electrical Connection, Electrical Accessories Page 12 ▷

Guidelines on safety-critical applications (acc. ISO 13849-1) Page 26 ▷

Guidelines Page 27 ▷

Order Number

Nominal torque holding brake	0	0	Without additional parts
100 % Nominal torque standard	1	1	Hand release ¹⁾
84 % Nominal torque ⁶⁾	2	2	Friction disk ⁷⁾
68 % Nominal torque ⁶⁾	3	3	Hand release/Friction disk ^{1) 7)}
50 % Nominal torque ⁶⁾	4	4	Flange plate ⁸⁾
34 % Nominal torque ⁶⁾	5	5	Hand release/Flange plate ^{1) 8)}
Nominal torque adjustable ^{2) 6)}	6		
112 % Nominal torque ⁶⁾	7		
125 % Nominal torque ⁶⁾	8		

_ / 8		9		1 . _		_ . _		_ / _		_ / _		_ / _	
▲		▲		▲		▲		▲		▲		▲	
Sizes	Standard brake metal rotor ³⁾	0	Standard ¹¹⁾	0	Coil voltage ⁹⁾		Bore		Keyway acc.				
2	Holding brake metal rotor	1	Enclosed	1	[VDC]		Hub Ø d		DIN 6885/1				
to	Standard brake	2	design IP65 ⁵⁾	2	24 ¹⁰⁾		(please observe		or				
1000	Friction lining rotor ⁴⁾	2	Tacho design ⁵⁾	3	104		dimensions pages		DIN 6885/3				
			Central torque		180		4-5, Table 2,						
			adjustment ²⁾		207		page 7)						

Example: 16 / 891.211.0 / 24 / 16 / 6885/1 **For Further Options, see page 10.**

- | | |
|---|---|
| <p>1) Hand release not installed on size 2 – size 500.
Size 1000: Hand release only available as emergency hand release.
Hand release for IP65 design only ex works.</p> <p>2) On request</p> <p>3) From size 60</p> <p>4) Up to size 32 (for brake operation in hoisting device drives, please contact the manufacturer)</p> <p>5) Not in combination with friction disk</p> | <p>6) See Technical Explanations pages 6 – 7</p> <p>7) Sizes 2 – 60</p> <p>8) Standard tacho brake flange plate</p> <p>9) Brake operation only possible with overexcitation on size 500 from 700 Nm onwards and on size 1000.</p> <p>10) Not possible on size 1000.</p> <p>11) Standard and tacho design are identical on size 1000.
Order number for standard (tacho design) on size 1000:
1000 / 891._.2 / _ / _ / _</p> |
|---|---|

 **ROBA-stop®-M safety brakes are also available in ATEX design according to the directive 94/9 EC (ATEX 95). (Please contact the manufacturer separately for this).**

 **On request ROBA-stop® safety brakes can also be delivered with UL approval.**

ROBA-stop®-M electromagnetic safety brakes

Type 891._.1.0

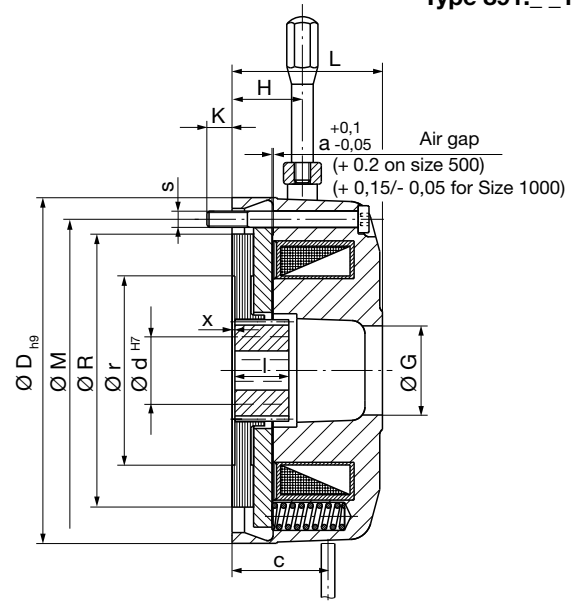
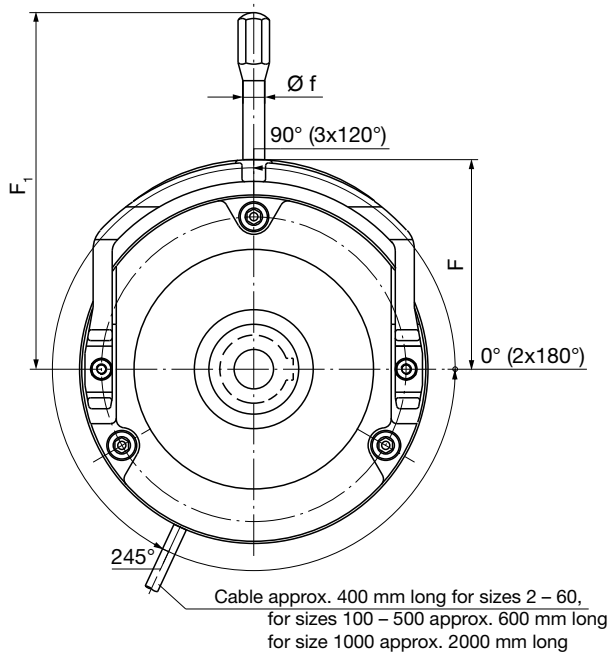

Technical Data			Size										
			2	4	8	16	32	60	100	150	250	500	1000
Braking Torque	Standard brake ¹⁾ Type 891.0_._. Type 891.2_._. ⁹⁾	M_N [Nm]	2	4	8	16	32	60	100	150	250	500 ^{1.1)}	1000 ^{1.1) 4)}
	Holding brake ^{1.1)} Type 891.1_._.	M_N [Nm]	4	8	16	32	64	100	180	250	450	800 ⁴⁾	1600 ⁴⁾
Electrical power	P_N [W]	19	25	29	38	46	69	88	98	120	152	160	
Maximum speed	n_{max} [rpm]	6000	5000	4000	3500	3000	3000	3000	1500	1500	1500	1500	
Weight	Standard brake Type 891.0_._. Type 891.2_._. ⁹⁾	m [kg]	0.76	1.1	1.8	3.4	4.5	7.4	13.6	19.2	33.3	38	79
	Holding brake Type 891.1_._.	m [kg]	0.76	1.1	1.8	3.4	4.5	7.4	13.6	19.2	33.3	38	79

Bores			Size										
			2	4	8	16	32	60	100	150	250	500	1000
Bore $\varnothing d_{H7.2}$	Standard brake Type 891.0_._. Type 891.2_._. ⁹⁾	min. [mm]	8	10	11	14	19	22	24	30	40 ^{1.2)}	50 ^{1.2)}	75
		max. [mm]	15	15	20	25	30	35	45	50	60	80	90
	Please observe Table 2, page 7												
	Holding brake Type 891.1_._.	min. [mm]	8	10	11	14	19	22	24	30	40	50	75
max. [mm]		15	15	20	25	30	35	45	50	55	75	90	
Please observe Table 2, page 7													

Dimensions [mm]	Size										
	2	4	8	16	32	60	100	150	250	500	1000
a	0.15	0.15	0.2	0.2	0.2	0.25	0.3	0.3	0.35	0.4	0.5
b	30	30	36	42	52	60	78	84	96	130	180
b ₁	30	30	36	42	52	62	-	-	-	-	-
c	24	26.5	28.7	35.5	39.2	50.5	54	59	69	70	85
c ₁	25	27.5	29.7	36.8	40.5	51.8	-	-	-	-	-
c ₂	29	32.5	34.7	42.5	47.2	58.5	64	71	83	89	106
D	76	87	103	128	148	168	200	221	258	310	382
D ₁	81	92	108	130	148	168	200	221	258	310	382
D ₂	81	92	108	134	154	174	206	227	266	318	392
F	48.5	54	63.5	77	88	100.5	123	133	153	179	-
F ₁	102.5	108	117.5	131	169	228.5	267	347	494	521	-
f	8	8	8	8	10	14	14	19	23	23	-

ROBA-stop®-M electromagnetic safety brakes

Type 891._.2.0
Standard with friction disk

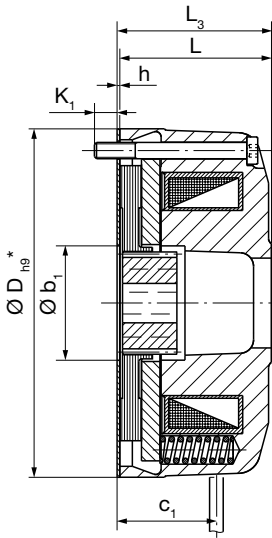

Type 891._.4.1
Enclosed design (IP 65)
with flange plate

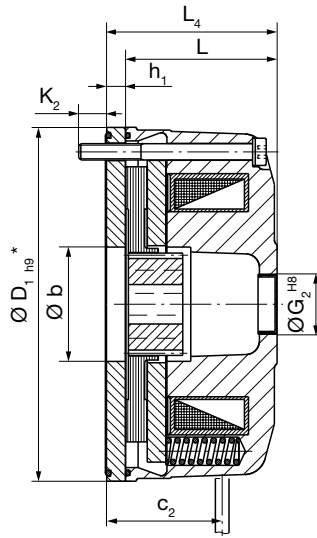

Type 891._.4.2
Tacho attachment design
with flange plate

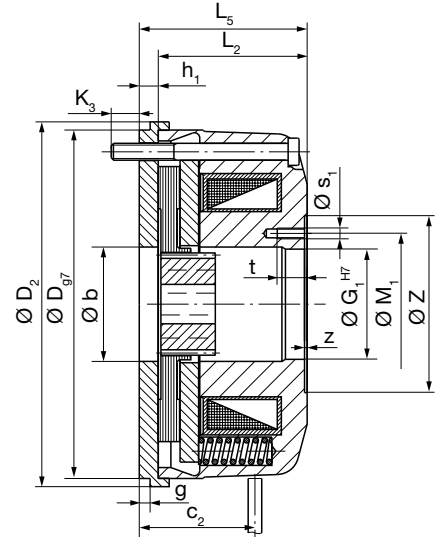

* Outer diameter friction disk: free size; outer diameter flange plate: -0.2

Missing dimensions are identical with Type 891.011.0 see page 4.

Dimensions [mm]	Size											
	2	4	8	16	32	60	100	150	250	500	1000	
G	16.5	18	22	33	36	38	48	55	65	85	100	
G₁	23.5	28.5	32.5	40.5	52.5	60	75.5	82.5	92	131	100	
G₂^{H8}	-	-	22	22	28	32	42	48	52	62	100	
g	4	4	4	4	4	4	5	6	7	7	7	
H	16	14.5	17.5	26	27	26	34	41	46	54.5	-	
h	1	1	1	1.25	1.25	1.25	-	-	-	-	-	
h₁	5	6	6	7	8	8	10	12	14	19	21	
K	10	10.8	12.5	12.3	8.3	12	12	20	20	22	18.5	
K₁	9	9.8	11.5	11.1	7.1	10.8	-	-	-	-	-	
K₂	10	8.8	11.5	10.3	10.3	14	12	18	25.5	21.5	17.5	
K₃	10	9.8	11.5	10.3	10.3	14	12	18	26	23	19	
L	39	41.5	45.2	55.7	61.7	72.5	84	97	116	114	135 ^{5) 6)}	
L₂	38	40.5	44.2	54.7	60.7	71.5	83	96	115	113	135 ⁶⁾	
L₃	40	42.5	46.2	57	63	73.8	-	-	-	-	-	
L₄	44	47.5	51.2	62.7	69.7	80.5	94	109	130	133	170 ⁵⁾	
L₅	43	46.5	50.2	61.7	68.7	79.5	93	108	129	132	156 ⁶⁾	
l	18	18	20	20	25	30	30	35	40	50 ³⁾	70	
	supporting length of the key											
M	66	72	90	112	132	145	170	196	230	278	325	
M₁	29	35	41	52	61	75	88	100	112	145	115.5	
R	57	65	81	101	121	130.5	154	178	206	253	300	
r	45	45	53	70	83	94	106	122	140	161	190	
s	3 x M4	3 x M4	3 x M5	3 x M6	3 x M6	3 x M8	3 x M8	3 x M8 ⁸⁾	3 x M10 ⁸⁾	6 x M10	6 x M12 ⁷⁾	
s₁	3 x M3	3 x M4	3 x M4	3 x M4	3 x M5	3 x M5	3 x M5	3 x M6	3 x M6	6 x M8	6 x M6	
t	6	10	10	10	10	10	10	10	10	13	12	
x	0	0	0	0 - 0.5	0 - 0.5	0 - 2	0 - 3	0 - 3	0 - 3	3 - 4	0 - 1.5	
Z	36	45	55	65	75	90	100	115	130	175	-	
z	1	1	1	1	1	1	1	1	1	1	-	

Standard voltages 24; 104; 180; 207 V.

Permitted voltage tolerance acc. DIN IEC 60038 (±10 %).

- 1) Braking torque tolerance on size 2-250 = +30 %/-10 %, for other adjustments see Table 3, page 7 and type key page 3.
- 1.1) Braking torque tolerance = +40 %/-20 % (friction lining pairing conditioning necessary, see Operational Instructions B.8.1.).
- 1.2) Minimum bore not permitted for braking torque adjustment = 125 %.
- 2) The respective maximum bores are to be seen in relation to the corresponding keyways and their tolerances acc. Table 2 page 7.
- 3) Hub facing side (both sides) 3 mm deep, Ø 97 recessed.

We reserve the right to make dimensional and constructional alterations.

- 4) Brake operation only possible with overexcitation
- 5) The IP65 design is equipped with a sealing cover on size 1000: L = 149 mm, L₄ = 170 mm.
- 6) Projection screw plugs (emergency hand release): 8.5 mm
- 7) For flange plate securement: additional 2 x M12 screws
- 8) For flange plate securement: additional 3 x M8/M10 screws
- 9) Only up to Size 32

ROBA-stop®-M – Short Description Installation

Installation Conditions

- ❑ The eccentricity of the shaft end in relation to the mounting pitch circle must not exceed 0.2 mm.
- ❑ The positional tolerance of the threaded holes for the cap screws (Item 8, Fig. 2) must not exceed 0.2 mm.
- ❑ The axial run-out deviation of the screw-on surface to the shaft must not exceed the permitted axial run-out tolerance acc. DIN 42955 N. Larger deviations can lead to a drop in torque, to continuous grinding of the rotor and to overheating.

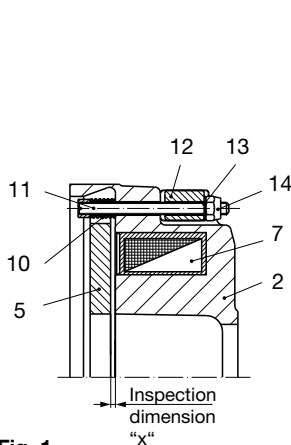

Fig. 1

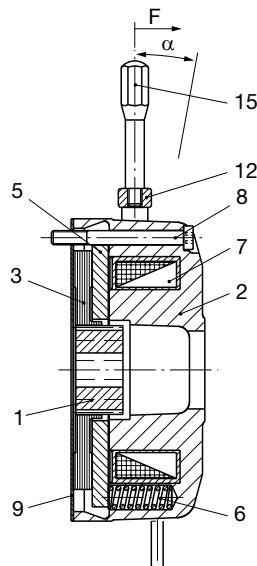

Fig. 2

Installation

1. Mount the hub (1) onto the shaft and secure it axially (e.g. using a locking ring).
 - Recommended tolerance of hub-shaft connection H7/k6.
 - Avoid too tight hub-shaft connections (particularly on max. bores).
 - Keep the friction surfaces free of oil and grease.

Attention!

Please observe supporting length of the key acc. Dimensions on page 5.

2. If necessary (dependent on Type), move the friction disk or the flange plate over the shaft and attach it to the machine wall (or screw on for size 1000).
 - If there are no suitable counter-friction surfaces made of grey cast or steel available, please use brake Types 891._ _2/3._ _ (with friction disk (9)) or 891._ _4/5._ _ (with flange plate).
 - When using a brake with a friction disk (Type 891._ _2/3._ _), please observe the stamp "friction side" on the friction disk.
3. Push the rotor (3) onto the hub (1) by hand.
4. If necessary, install the hand release (only on sizes 2 - 500/the emergency hand release is partly assembled on size 1000).
5. If necessary (dependent on Type, Type 891._ _ _1), insert the O-ring into the axial recess of the coil carrier (2).
6. Push the rest of the brake over the hub (1) and the rotor collar (3).
7. Attach the brake onto the motor bearing shield or onto the machine wall evenly all around using the cap screws (8) - please observe the seal dependent on the type - with a torque wrench and tightening torque (acc. Table 1, page 7).

Attention!

Only use mayr® original screws (Table 1, page 7).

Braking Torque Adjustment

Different torque adjustments can be made using different spring configurations (6) in the coil carrier (2) (see Table 3, page 7).

Hand Release Installation (Sizes 2 – 500)

On Type 891._ _ _1 installation of the hand release is only possible if a request for a hand release is stated on the brake order form (completely enclosed coil carrier (2)).

For hand release installation, the brake must be dismantled and de-energised.

Installation Procedure (Figs. 1 and 2):

1. Unscrew brake from the motor bearing shield or from the machine wall.
2. Remove the sealing plugs from the hand release bores in the coil carrier (2).
3. Put the thrust springs (10) onto the threaded bolts (11). The threaded bolts (11) come manufacturer-side assembled with a key as tension element and secured with adhesive up to Size M60. This connection must not be loosened.
4. Push the threaded bolts (11) with thrust springs (10) from the inside (you should be facing the magnetic coil (7)) into the hand release bores in the coil carrier (2).
5. Push the O-rings (only with sealed hand release, Type 891._ _ _1) over the threaded bolts (11) and insert them into the recesses of the coil carrier (2).
6. Push intermediate plates (only with sealed hand release, Type 891._ _ _1) over the threaded bolts (11).
7. Mount the switch bracket (12), add the washers (13) and lightly screw on the self-locking hexagon nuts (14).
8. Tighten both hexagon nuts (14) until the armature disk (5) lies evenly against the coil carrier (2).
9. Loosen both hexagon nuts (14) by "Y" turns (see Table 1, page 7), thereby creating an air gap between the armature disk (5) and the coil carrier (2) or the inspection dimension "x" (see Page 7, Table 1).

Attention!

An uneven adjustment dimension on the hand release can cause the brake to malfunction.

10. After installing the release cover, screw the hand release rod (15) into the switch bracket (12) and tighten it. The hand release rod (15) must be protected against loosening using a screw-securing product, e.g. Loctite 243.

Maintenance

ROBA-stop®-M brakes are mainly maintenance-free.

However, the rotor (3) is subject to operational wear.

The friction linings are robust and wear-resistant. This ensures a particularly long service lifetime.

If the rotor (3) does become worn due to the high total friction work, and the function of the brake can no longer be guaranteed, the brake can be re-set to its functional state by replacing the rotor. For this, the brake must be cleaned thoroughly.

The wear condition of the rotor (3) is determined by measuring the release voltage (this must not exceed max. 90 % of the nominal voltage on a warm brake), or by measuring the rotor thickness on a dismantled brake ("minimum rotor thickness" acc. Table in the currently valid Installation and Operational Instructions). On sizes 500 and 1000 there is an air gap inspection opening. This means that the brake does not have to be dismantled.

Attention!

The brake function cannot be guaranteed on brakes with a reduced braking torque and/or operation with a fast-acting rectifier if the friction linings are heavily worn.

Unpermitted high wear relaxes the thrust springs (6), leading to a drop in torque.

ROBA-stop®-M – Short Description Installation

Technical Data – Installation			Size											
			2	4	8	16	32	60	100	150	250	500	1000	
Inspection dimension	x	[mm]	0.9 ^{+0.1}	0.9 ^{+0.1}	1.1 ^{+0.1}	1.6 ^{+0.1}	1.8 ^{+0.1}	2.2 ^{+0.1}	2.2 ^{+0.1}	2.2 ^{+0.1}	2.4 ^{+0.1}	2.4 ^{+0.1}	-	
Number of rotations	Y	[-]	1.7	1.7	1.5	2.0	2.0	2.0	1.6	1.6	1.5	1.5	-	
Release force	Standard brake Type 891.0_ _ _ Type 891.2_ _ _	F	[N]	20	35	70	100	130	220	260	290	350	310	-
	Holding brake Type 891.10_ _ _	F	[N]	26	45	90	125	170	300	340	350	430	470	-
Release angle	α	[°]	6	7	7	7	8	10	12	13	10	10	-	
Fixing screws (8) (Item 8, Fig. 2, Page 6)	Type 891._ _ 0_ _	[-]	3 x M4 x 45	3 x M4 x 45	3 x M5 x 50	3 x M6 x 60	3 x M6 x 60	3 x M8 x 75	3 x M8 x 80	3 x M8 x 100	3 x M10 x 110	6 x M10 x 110	6 x M12 x 130	
			DIN	6912	6912	6912	6912	6912	6912	EN ISO 4762	EN ISO 4762	EN ISO 4762	EN ISO 4762	EN ISO 4762
	Type 891._ _ 4_ _	[-]	3 x M4 x 50	3 x M4 x 50	3 x M5 x 55	3 x M6 x 65	3 x M6 x 70	3 x M8 x 85	3 x M8 x 90	3 x M8 x 110	3 x M10 x 130	6 x M10 x 130	6 x M12 x 150	
			DIN	EN ISO 4762	EN ISO 4762	6912	6912	EN ISO 4762	EN ISO 4762	EN ISO 4762	EN ISO 4762	EN ISO 4762	EN ISO 4762	EN ISO 4762
Tightening torque	T _A	[Nm]	2.5	2.5	5.0	9.0	9.0	22	22	22	45	45	83	
Rotor thickness “new condition“		[mm]	6.05	6.05	6.9	8	10.4	11.15	14	15.5	17	18.5	18.5	

Table 1

Permitted Hub Bores $\varnothing d_{max}$			Size											
			2	4	8	16	32	60	100	150	250	500	1000	
Type 891.0_ _ _ Type 891.2_ _ _	Keyway JS9	6885/1	[mm]	13	13	18	22	30	32	42	45	55	75	90
		6885/3	[mm]	15	15	20	25	-	35	45	50	60	80	-
	Keyway P9	6885/1	[mm]	13	13	18	20	28	32	42	45	50	75	90
		6885/3	[mm]	15	15	20	22	30	-	45	50	55	80	-
Type 891.1_ _ _	Keyway JS9	6885/1	[mm]	13	13	18	22	30	32	42	45	55	75	90
		6885/3	[mm]	15	15	20	25	-	35	45	50	-	-	-
	Keyway P9	6885/1	[mm]	13	13	18	20	28	32	42	45	50	75	90
		6885/3	[mm]	15	15	20	22	30	-	45	50	55	-	-

Table 2

Braking Torque Adjustments			Size											
			2	4	8	16	32	60	100	150	250	500	1000 ¹⁾	
Holding brake			[Nm]	4	8	16	32	64	100	180	250	450	800 ¹⁾	1600
Standard brake	Braking torque ²⁾ in %	125 %	[Nm]	2.5	5	10	20	40	75	125	185	310	700 ¹⁾	1400
		112 %	[Nm]	2.2	4.5	9	18	36	68	110	165	280	600	1200
		100 %	[Nm]	2	4	8	16	32	60	100	150	250	500	1000
		84 %	[Nm]	1.7	3.4	6.8	13.5	27	50	85	125	215	400	800
		68 %	[Nm]	1.4	2.8	5.5	11	22	41	70	100	180	350	700
		50 %	[Nm]	1	2	4	8	16	30	50	75	125	250	500
		34 %	[Nm]	0.7	1.4	2.8	5.5	11	21	-	-	-	200	400

Table 3

- 1) Brake operation only possible with overexcitation.
- 2) The braking torque (switching torque) is the torque effective in the shaft train of a slipping brake with a sliding speed of 1 m/s in relation to the mean friction radius (acc. VDE 0580/07.2000).

ROBA-stop®-M – Brake Dimensioning

Brake Size Selection

1. Brake selection

$$M_{\text{eff.}} = \frac{9550 \times P}{n} \times K \leq M_2 \quad [\text{Nm}]$$

$$t_v = \frac{J \times n}{9.55 \times M_v} \quad [\text{sec}]$$

$$M_v = M_N + (-) * M_L \quad [\text{Nm}]$$

2. Inspection of thermic load

$$Q_r = \frac{J \times n^2}{182.4} \times \frac{M_2}{M_v} \quad [\text{J/ braking}]$$

The permitted friction work (switching work) $Q_{r \text{ zul.}}$ per braking for the specified switching frequency can be taken from the friction-power diagrams (page 9).

If the friction work (switching work) per braking is known, the max. switching frequency can also be taken from the Friction-Power Diagrams (page 9).

Names:

J	[kgm ²]	Mass moment of inertia
K	[-]	Safety factor (≥1.5–3 x according to conditions)
$M_{\text{eff.}}$	[Nm]	Required braking torque
M_L	[Nm]	Load torque * sign in brackets (-) is valid if load is braked during downward movement
M_N	[Nm]	Nominal torque (Technical Data page 4) <u>Please observe the braking torque tolerance!</u>
n	[rpm]	Speed
P	[kW]	Input power
t_v	[s]	Braking action
t_1	[s]	Connection time (Table 6 page 12)
Q_r	[J]	Friction work present per braking
$Q_{r \text{ 0.1}}$	[J]	Friction work per 0.1 mm wear (Table 4)
$Q_{r \text{ ges.}}$	[J]	Friction work up to rotor replacement (Table 4)
$Q_{r \text{ zul.}}$	[J]	Permitted friction work (switching work) per braking action



Due to operating parameters such as sliding speed, pressing or temperature the **wear values** can **only be considered guideline values**.

When using a brake with a friction disk (Type 891._.2._.), the max. friction work and friction power must be reduced by 30 % for Sizes 2 to 16 and by 50 % for Sizes 32 – 60. The wear values $Q_{r \text{ 0.1}}$ and $Q_{r \text{ ges.}}$ are therefore not valid.

Friction Work				Size										
				2	4	8	16	32	60	100	150	250	500	1000
per 0.1 mm wear	Standard brake Type 891.0_._._ Type 891.2_._._	$Q_{r \text{ 0.1}}$	[10 ⁶ J]	35	40	65	100	130	130	140	150	160	170	180
	Holding brake Type 891.1_._._	$Q_{r \text{ 0.1}}$	[10 ⁶ J]	7	8	13	20	30	65	70	75	80	85	90
up to rotor replacement	Standard brake Type 891.0_._._ Type 891.2_._._	$Q_{r \text{ ges.}}$	[10 ⁶ J]	95	100	162	500	600	700	840	950	1000	1700	2000
	Holding brake Type 891.1_._._	$Q_{r \text{ ges.}}$	[10 ⁶ J]	7	8	13	20	45	130	170	300	350	425	540

Table 4

Mass Moment of Inertia Rotor + hub with d_{max}				Size										
				2	4	8	16	32	60	100	150	250	500	1000
Type 891.0_._._ (Metal rotor) Type 891.1_._._ (Metal rotor)	J_{R+H}	[10 ⁻⁴ kgm ²]		0.12	0.21	0.67	1.74	4.48	6.74	16.54	31.68	61.82	222.6	424
Type 891.2_._._ (Friction lining rotor)	J_{R+H}	[10 ⁻⁴ kgm ²]		0.1	0.17	0.58	1.53	4.1	-	-	-	-	-	-

Table 5

ROBA-stop[®]-M – Friction-Power Diagrams

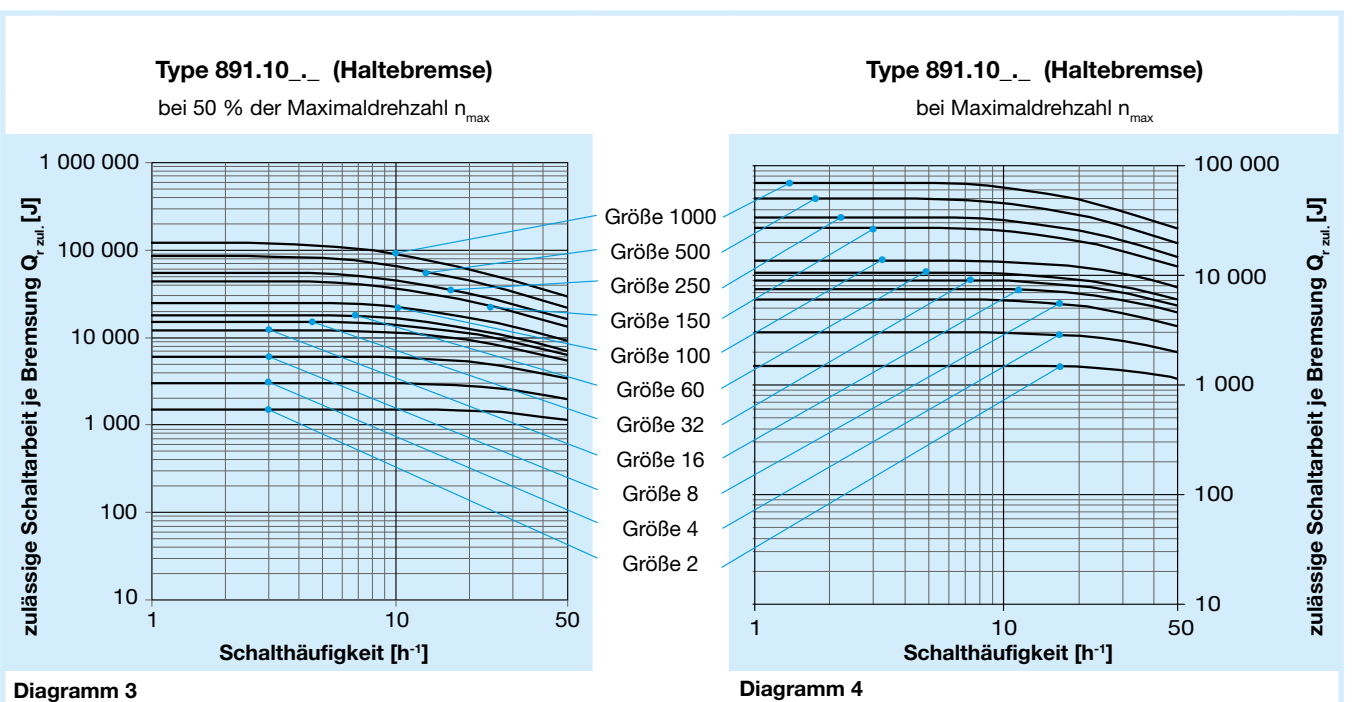
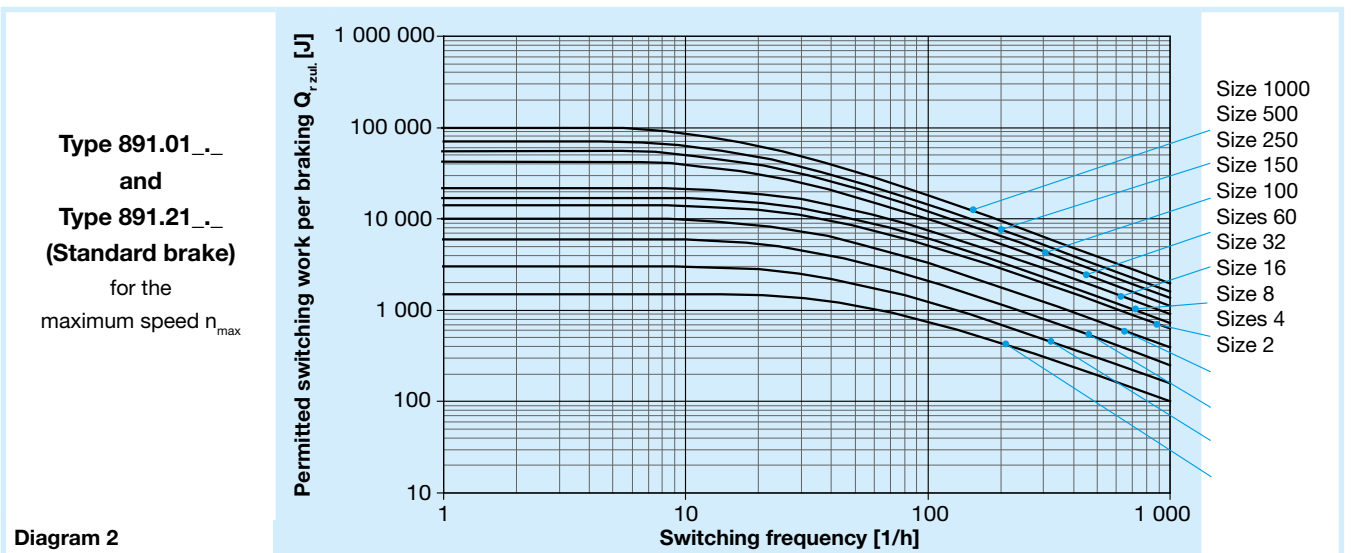
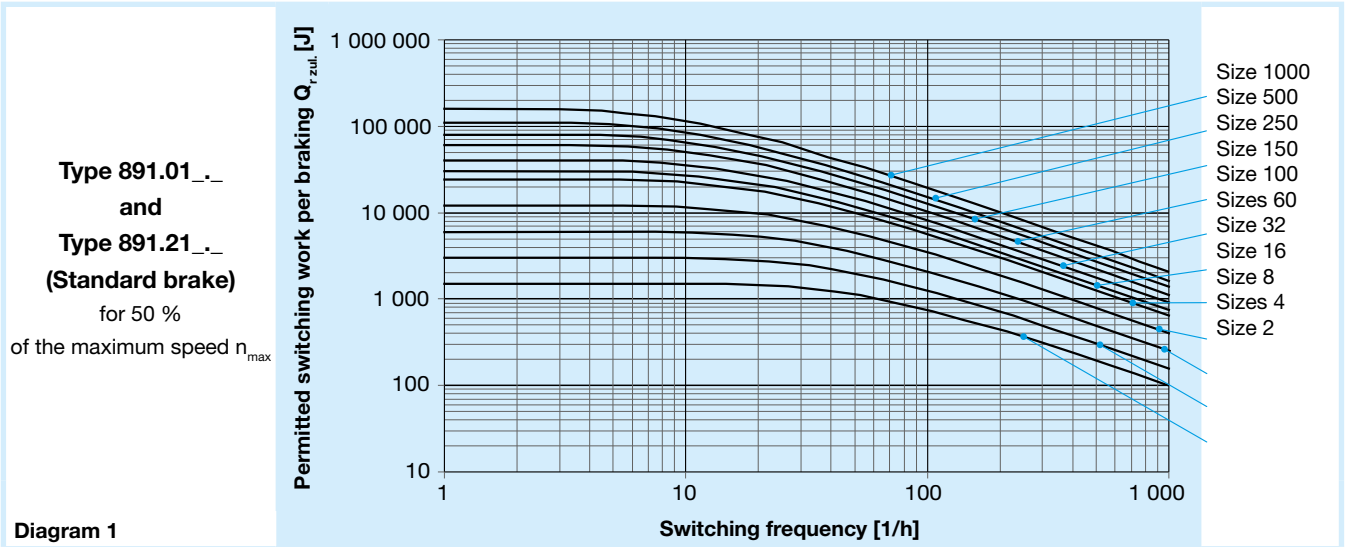

ROBA-stop[®]-M – Further Options

In addition to the standard brakes, *mayr*[®] power transmission provides a multitude of further designs, which cannot be described in detail in this catalogue.

Some of the most frequently requested options are:

- Microswitch / proximity switch for switching condition indication (release monitoring), Fig. 1
- Microswitch for wear indication (wear monitoring), Fig. 2
- Customer-specific flange plate, Fig. 3
- IP65 design for continuous shafts, Fig. 4
- Noise damping (O-ring damping between the gear hub and the rotor), Fig. 5
- ACH = Anti-Condensation heating, Fig. 6
- Lockable hand release
- Double rotor design, Fig. 8
- CCV-design, Fig. 9
- ATEX design
- Special friction material
- Backlash-free design
- Special coil voltages

Please contact *mayr*[®] power transmission for further information

Release monitoring

When the magnetic coil in the coil carrier (2) is energised, the armature disk (3) is pulled towards the coil carrier (2). The microswitch / proximity switch (1) emits a signal and the brake is released.

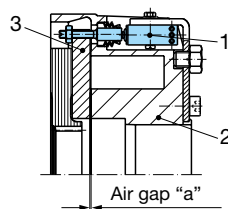

Fig. 1

Continuous shaft with IP65

The enclosed design (IP65) is equipped with a screw plug (sizes 8 to 500) or with a sealing cover (size 1000) (see Type 891._14.1, page 5) as part of the standard delivery.

A radial shaft sealing ring (1) is installed in the coil carrier (2) on continuous shafts.

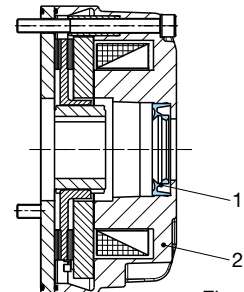

Fig. 4

Wear monitoring

Due to wear on the rotor (5), the nominal air gap "a" between the coil carrier (2) and the armature disk (3) increases. If the limit air gap (see table in the Installation and Operational Instructions) is reached, the microswitch contact (1) switches over and emits a signal. The rotor (5) must be replaced.

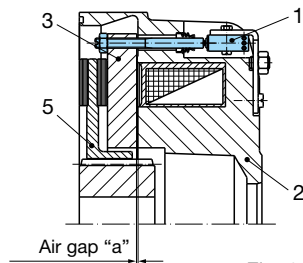

Fig. 2

Damping rotor / toothed hub

If vibrations in the drive line cannot be avoided, an O-ring (1) is used to damp backlash between the toothed hub (6) and the rotor (5).

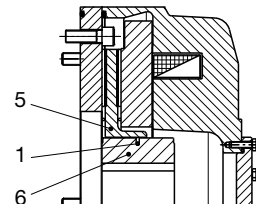

Fig. 5

Special flange plate

We offer a range of flange plates for customer-specific solutions, such as for example the special flange plate shown in Fig. 7 (1) with customer-tailored centering (8) and sealing (7).

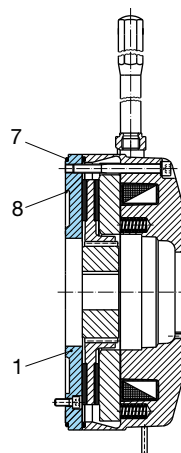

Fig. 3

Anti-condensation heating

The anti-condensation heating (1) is used to prevent condensation formation inside the brake.

Its usage is especially recommended at temperatures below 0 °C or in high air humidity.

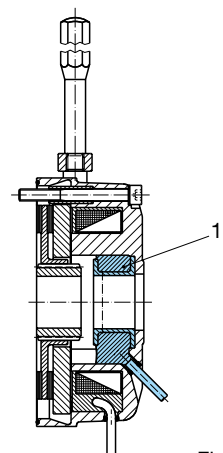
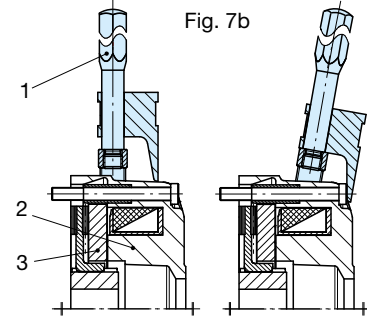
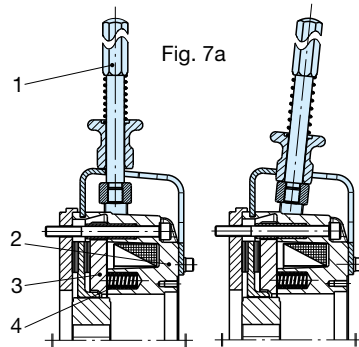

Fig. 6

ROBA-stop[®]-M – Further Options

Lockable hand release

In de-energised condition, the brake with lockable hand release can be released manually. By deflecting the hand release rod (1), the armature disk (3) is pushed against the thrust springs (4) onto the coil carrier (2) and the braking torque is removed, Figs. 7a and 7b.



		Hand release in starting position	Hand release in engagement position	Hand release in starting position	Hand release in engagement position
Coil	de-energised	Shaft braked	Shaft runs free	Shaft braked	Shaft runs free
	energised	Shaft runs free	Shaft runs free	Shaft runs free	Shaft runs free

Double rotor design

Double rotor design for increased torque at small outside diameter.

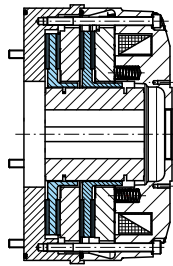

Fig. 8

CCV-design

Cold Climate safety brake Type 891.4... Sizes 16 - 150
GL-certified up to -40 °C.

For further information please see brochure: ROBA-stop[®]-M
CCV P.891400.V

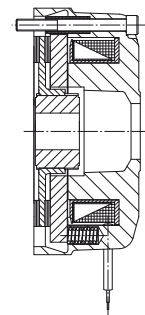

Fig. 9

ROBA-stop®-M – Switching Times

Switching Times

The values stated in the table are mean values which refer to the nominal air gap and the nominal torque on a warm brake.

Switching times ¹⁾			Size										
			2	4	8	16	32	60	100	150	250	500	1000
Nominal torque (100 %)		M_2 [Nm]	2	4	8	16	32	60	100	150	250	500	1000
Connection time	DC-side switching	t_1 [ms]	10	18	20	30	50	55	68	80	100	100	180
	AC-side switching	t_1 [ms]	100	160	220	320	400	500	640	730	1100	1100	1200
Response delay on connection	DC-side switching	t_{11} [ms]	6	12	16	25	35	35	38	40	50	30	70
	AC-side switching	t_{11} [ms]	80	130	175	240	300	350	400	450	700	700	750
Separation ²⁾		t_2 [ms]	33	36	54	84	120	180	216	264	348	480	336 ³⁾
Nominal torque (84 %)		M_2 [Nm]	1.7	3.4	6.8	13.5	27	51	85	125	215	400	840
Connection time	DC-side switching	t_1 [ms]	16	29	32	48	80	88	109	128	160	160	288
	AC-side switching	t_1 [ms]	160	256	352	512	640	800	1024	1168	1760	1760	1920
Response delay on connection	DC-side switching	t_{11} [ms]	9.6	19	26	40	56	56	61	64	80	48	112
	AC-side switching	t_{11} [ms]	128	208	280	384	480	560	640	720	1120	1120	1200
Separation time		t_2 [ms]	24	26	39	61	87	130	157	191	252	348	235 ³⁾
Nominal torque (68 %)		M_2 [Nm]	1.4	2.8	5.5	11	22	42	70	100	180	350	680
Connection time	DC-side switching	t_1 [ms]	22	40	44	66	110	121	150	176	220	220	396
	AC-side switching	t_1 [ms]	220	352	484	704	880	1100	1408	1606	2420	2420	2640
Response delay on connection	DC-side switching	t_{11} [ms]	13	26	35	55	77	77	84	88	110	66	154
	AC-side switching	t_{11} [ms]	176	286	385	528	660	770	880	990	1540	1540	1650
Separation time		t_2 [ms]	21	23	34	53	75	113	135	165	218	300	203 ³⁾

Table 6

- 1) Standard brakes with a braking torque adjustment of 34% and 50 % have substantially longer connection times t_1 and must not be used for switching time-relevant applications.
- 2) The separation time t_2 of holding brakes is 1.4 times longer than the separation time of standard brakes (100 %).
- 3) Value for operation with overexcitation

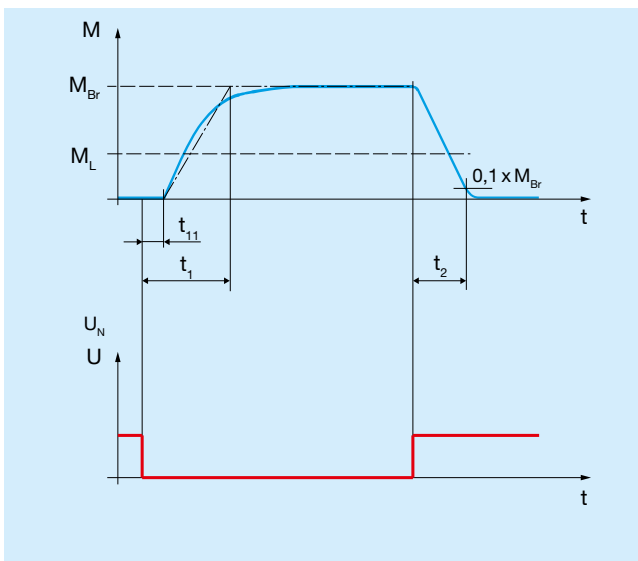

Diagram 5: Switching times for brake operation with coil nominal voltage

Names:

- M_{Br} = Braking torque
- M_L = Load torque
- t_1 = Connection time
- t_{11} = Response delay on connection
- t_2 = Separation time
- U_N = Coil nominal voltage

ROBA-stop®-M – Electrical Connection

Electrical Connection and Wiring

DC current is necessary for operation of the brake. The coil voltage is indicated on the Type tag as well as on the brake body and is designed according to the DIN IEC 60038 ($\pm 10\%$ tolerance). Operation can take place with alternating voltage using a *mayr*®-DC voltage module or another suitable DC power supply. The connection possibilities can vary dependent on the brake equipment. Please follow the exact connections according to the Wiring Diagram. The manufacturer and the user must observe the applicable regulations and standards (e.g. DIN EN 60204-1 and DIN VDE 0580). Their observance must be guaranteed and double-checked!

Earthing Connection

The brake is designed for Protection Class I. This protection covers not only the basic insulation, but also the connection of all conductive parts to the protective conductor (PE) on the fixed installation. If the basic insulation fails, no contact voltage will remain. Please carry out a standardised inspection of the protective conductor connections to all contactable metal parts!

Device Fuses

To protect against damage from short circuits, please add suitable device fuses to the mains cable.

Switching Behaviour

The reliable operational behaviour of a brake is to a large extent dependent on the switching mode used. Furthermore, the switching times are influenced by the braking torque adjustment, temperature and the air gap between the armature disk and the coil carrier (dependent on the wear condition of the linings).

Magnetic Field Build-up

When the voltage is switched on, a magnetic field is built up in the brake coil, which attracts the armature disk to the coil carrier and releases the brake.

• Field Build-up with Normal Excitation

If the magnetic coil is energised with nominal voltage, the coil current does not immediately reach its nominal value. The coil inductivity causes the current to increase slowly as an exponential function. Accordingly, the build-up of the magnetic field takes place more slowly and the braking torque drop (curve 1, diagram 6) is also delayed.

• Field Build-up with Overexcitation

A quicker drop in braking torque is achieved if the coil is temporarily placed under a higher voltage than the nominal voltage, as the current then increases more quickly.

Once the brake is released, it needs to be switched over to the nominal voltage (curve 2, diagram 6). The relationship between overexcitation and separation time t_2 is roughly indirectly proportional. This means that, using overexcitation voltage U_o (= doubled nominal voltage U_N), the separation time t_2 for release of the brake is halved. The ROBA®-switch fast acting rectifier works on this principle.

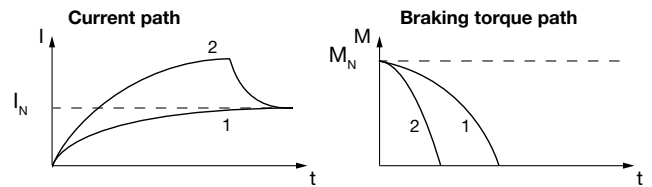

Diagram 6

Operation with overexcitation requires an inspection of :

- the required overexcitation time *
- as well as the RMS coil capacity ** with a cycle frequency higher than 1 cycle per minute (see page 14).

* Overexcitation time t_o

Increased wear, and therefore an increasing air gap as well as coil heating lengthen the separation times t_2 for the brake. For this reason, at least double the separation time t_2 at nominal voltage must be selected as overexcitation time t_o on each brake size

The spring forces also influence the brake separation times t_2 : Higher spring forces increase the separation times t_2 and lower spring forces reduce the separation times t_2 .

**** Coil capacity P**

i

$P \leq P_N$

The coil capacity P must not be larger than P_N . Otherwise the coil may fail due to thermic overload.

Calculations:

P	[W]	RMS coil capacity dependent on switching frequency, overexcitation, reduction in capacity and duty cycle
		$P = \frac{P_o \times t_o + P_H \times t_H}{T}$
P_N	[W]	Coil nominal capacity (catalogue values, Type tag)
P_o	[W]	Coil capacity on overexcitation
		$P_o = \left(\frac{U_o}{U_N} \right)^2 \times P_N$
P_H	[W]	Coil capacity at reduced capacity
		$P_H = \left(\frac{U_H}{U_N} \right)^2 \times P_N$
t_o	[s]	Overexcitation time
t_H	[s]	Time of operation with reduction in capacity
t_{off}	[s]	Time without voltage
t_{on}	[s]	Time of operation ($t_o + t_H$)
T	[s]	Total time ($t_o + t_H + t_{off}$)
U_o	[V]	Overexcitation voltage (bridge voltage)
U_H	[V]	Holding voltage (half-wave voltage)
U_N	[V]	Coil nominal voltage

Time Diagram:

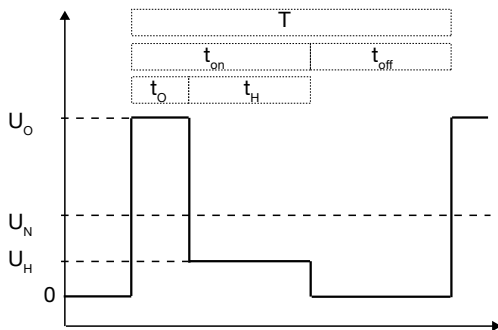
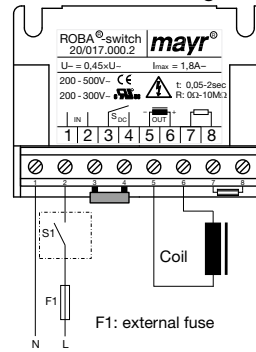

Diagram 7

For brakes, which do not require overexcitation, the holding voltage U_H may be lower than the nominal voltage U_N , e.g. on power reduction to reduce the coil temperature.

Magnetic Field Removal

• AC-side Switching



The power circuit is interrupted in front of the *mayr*[®]-DC voltage module. The magnetic field slowly reduces. This delays the rise in braking torque.

When switching times are not important, please switch AC-side, as no protective measures are necessary for the coil and the switching contacts.

AC-side switching means **low-noise switching**; however, the brake engagement time is longer (approx. 6 – 10 times longer than with DC-side switch-off), use for non-critical braking times.

• DC-side Switching

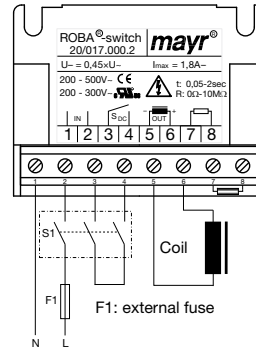

The power circuit is interrupted between the *mayr*[®]-DC voltage module and the coil as well as mains-side. The magnetic field reduces extremely quickly. This causes a quick rise in braking torque.

When switching DC-side, high voltage peaks are produced in the coil, which can lead to wear on the contacts from sparks and to destruction of the insulation.

DC-side switching means **short brake engagement times (e.g. for EMERGENCY STOP operation)**; however, louder switching noises.

• Protection Circuit

When using DC-side switching, the coil must be protected by a suitable protection circuit according to VDE 0580, which is integrated in *mayr*[®]-DC voltage module. To protect the switching contact from consumption when using DC-side switching, additional protective measures may be necessary (e.g. series connection of switching contacts). The switching contacts used should have a minimum contact opening of 3 mm and should be suitable for inductive load switching. Please make sure on selection that the rated voltage and the rated operating current are sufficient. Depending on the application, the switching contact can also be protected by other protection circuits (e.g. *mayr*[®]-spark quenching unit), although this may of course then alter the switching times.

Electrical Accessories

Functions of the DC Voltage Modules

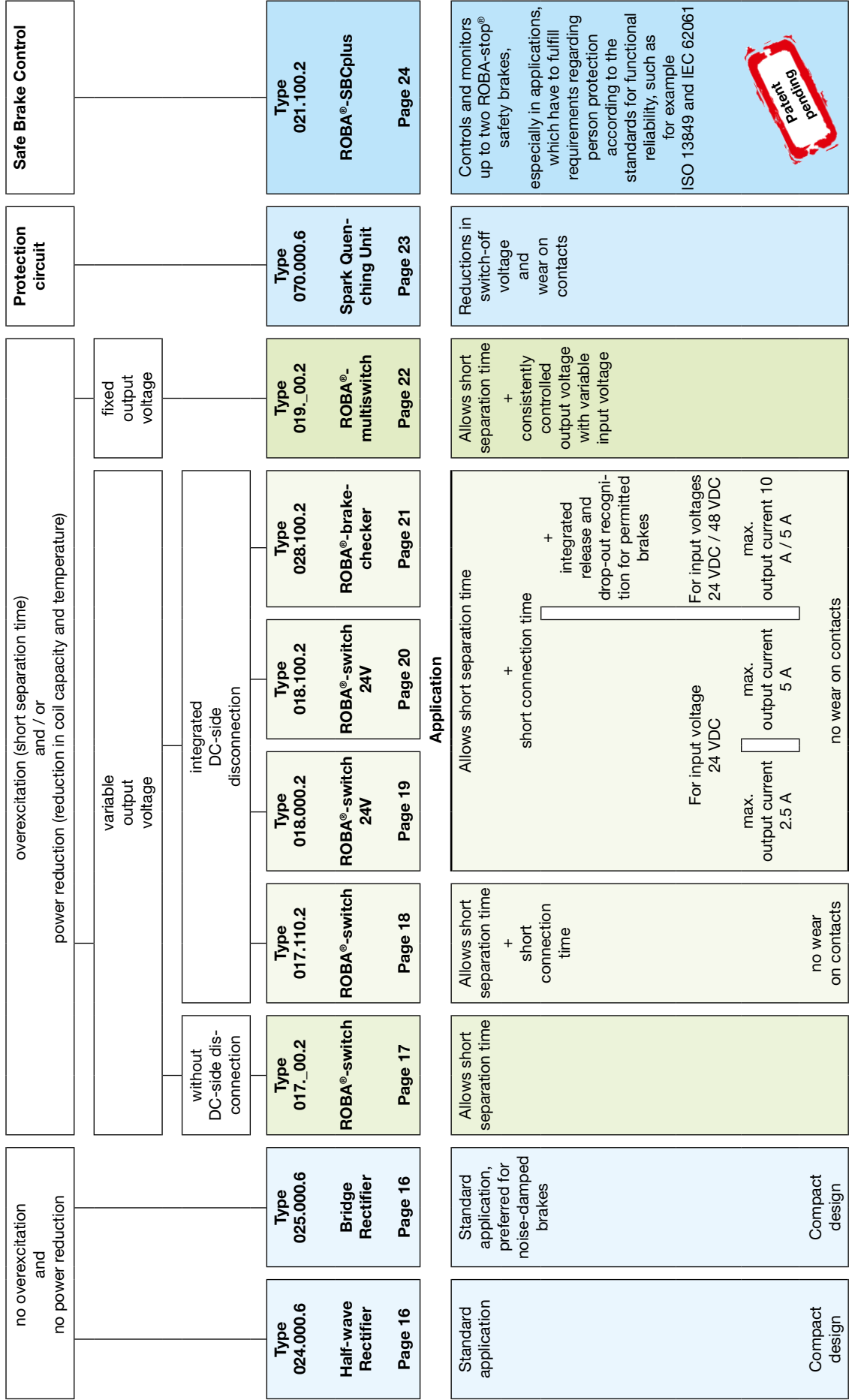

For detailed information on our DC voltage modules, please go to: www.mayr.com

Half-wave and bridge rectifiers Type 02_000.6

Application

Rectifiers are used to connect DC consumers to alternating voltage supplies, for example electromagnetic brakes and clutches (ROBA-stop[®], ROBA-quick[®], ROBATIC[®]), electromagnets, electrovalves, contactors, switch-on safe DC motors, etc.

Function

The AC input voltage U_i is rectified in order to operate consumers with DC voltage U_o . Also, voltage peaks, which occur when switching off inductive loads and which may cause damage to insulation and contacts, are limited and the contact load reduced.

Electrical Connection (Terminals)

- 1 + 2 Input voltage
- 3 + 4 Connection for an external switch for DC-side switching
- 5 + 6 Coil
- 7 - 10 Free nc terminals (only for Size 2)



Dimensions (mm)

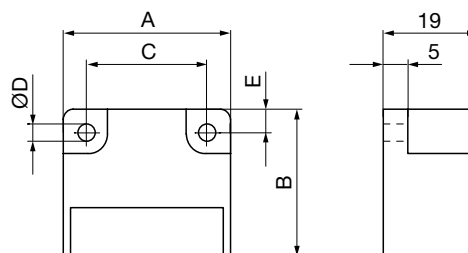

Size	A	B	C	ØD	E
1	34	30	25	3.5	4.5
2	54	30	44	4.5	5.0
3/4	64	30	54	4.5	5.0

Order Number

___ / 0 2 ___ . 0 0 0 . 6

Size	4	5
1 up to 4	Half-wave rectifier	Bridge rectifier

Accessories: Mounting bracket set for 35 mm rail acc. EN 60715: Article No. 1803201

Technical Data

				Bridge rectifier		Half-wave rectifier				
Calculation output voltage				VDC = VAC x 0.9		VDC = VAC x 0.45				
Type				1/025	2/025	1/024	2/024	3/024	4/024	
Max. input voltage	± 10 %	U_i	[VAC]	230	230	400	400	500	600	
Max. output voltage		U_o	[VDC]	207	207	180	180	225	270	
Output current	≤ 50 °C	I_{RMS}	[A]	2.5	2.5	3.0	4.0	4.0	4.0	
	at max. 85 °C	I_{RMS}	[A]	1.7	1.7	1.8	2.4	2.4	2.4	
Max. coil nominal capacity at	$U_{AC} = 115$ VAC	≤ 50 °C	P_N	[W]	260	260	-	-	-	
		up to 85 °C	P_N	[W]	177	177	-	-	-	
	$U_{AC} = 230$ VAC	≤ 50 °C	P_N	[W]	517	517	312	416	416	
		up to 85 °C	P_N	[W]	352	352	187	250	250	
	$U_{AC} = 400$ VAC	≤ 50 °C	P_N	[W]	-	-	540	720	720	
		up to 85 °C	P_N	[W]	-	-	324	432	432	
	$U_{AC} = 500$ VAC	≤ 50 °C	P_N	[W]	-	-	-	-	900	
		up to 85 °C	P_N	[W]	-	-	-	-	540	
	$U_{AC} = 600$ VAC	≤ 50 °C	P_N	[W]	-	-	-	-	-	1080
		up to 85 °C	P_N	[W]	-	-	-	-	-	648
	Peak reverse voltage			[V]	1600	1600	2000	1600	2000	2000
	Rated insulation voltage		U_{RMS}	[V _{RMS}]	320	320	500	500	630	630
Pollution degree (insulation coordination)				1	1	1	1	1	1	
Device fuses				To be included in the input voltage line.						
Recommended microfuse switching capacity H				FF 3.15 A	FF 3.15 A	FF 4 A	FF 5 A	FF 5 A	FF 5 A	
Permitted limit integral		I^2t	[A ² s]	40	40	50	100	50	50	
Protection				IP65 components, encapsulated / IP20 terminals						
Terminals				Cross-section 0.14 – 1.5 mm ² (AWG 26-14)						
Ambient temperature			[°C]	-25 to +85						
Storage temperature			[°C]	-40 to +85						
Conformity markings				UL, CE	UL, CE	UL, CE	UL, CE	UL, CE	CE	
Installation conditions				The installation position can be user-defined. Please ensure sufficient heat dissipation and air convection! Do not install near to sources of intense heat!						

ROBA®-switch Type 017._00.2

Application

ROBA®-switch fast acting rectifiers are used to connect DC consumers to alternating voltage supplies, for example electromagnetic brakes and clutches (ROBA-stop®, ROBA®-quick, ROBATIC®) as well as electromagnets, electrovalves, etc.

Fast acting rectifier ROBA®-switch 017._00.2

- Consumer operation with overexcitation or power reduction
- Input voltage: 100 – 500 VAC
- Maximum output current I_{RMS} : 3 A at 250 VAC
- UL-approved

Function

The ROBA®-switch is used for operation at an input voltage U_i of between 100 and 500 VAC, depending on the size. They can switch internally from bridge rectification U_o output voltage to half-wave rectification U_H output voltage. The bridge rectification time can be modified from 0.05 to 2 seconds by exchanging the external resistor (R_{ext}).









Electrical Connection (Terminals)

- 1 + 2 Input voltage (fitted protective varistor)
- 3 + 4 Connection for external contact for DC-side switch-off
- 5 + 6 Output voltage (fitted protective varistor)
- 7 + 8 R_{ext} for bridge rectification time adjustment

Technical Data

Input voltage	see Table 1
Output voltage	see Table 1
Protection	IP65 components, IP20 terminals, IP10 R_{ext}
Terminal nom. cross-section	1.5 mm ² (AWG 22-14)
Ambient temperature	-25 °C bis +70 °C
Storage temperature	-40 °C up to +70 °C

ROBA®-switch Sizes, Table 1

		Size			
		Type 017.000.2		Type 017.100.2	
		10	20	10	20
Input voltage ± 10 %	U_i [VAC]	100–250	200–500	100–250	200–500
Output voltage	U_o [VDC]	90–225	180–450	90–225	180–450
	U_H [VDC]	45–113	90–225	45–113	90–225
Output current	at ≤ 45 °C I_{RMS} [A]	2.0	1.8	3.0	2.0
	at max. 70 °C I_{RMS} [A]	1.0	0.9	1.5	1.0
Conformity markings					
					

Order Number

_ / 0 1 7 . _ 0 0 . 2						
▲ ▲						
<table border="0"> <tr> <td style="text-align: center;">Size</td> <td style="text-align: center;">UL-approved</td> </tr> <tr> <td style="text-align: center;">10</td> <td style="text-align: center;">0 up to 300 V</td> </tr> <tr> <td style="text-align: center;">20</td> <td style="text-align: center;">1 up to 500 V</td> </tr> </table>	Size	UL-approved	10	0 up to 300 V	20	1 up to 500 V
Size	UL-approved					
10	0 up to 300 V					
20	1 up to 500 V					



Dimensions (mm)

Type 017.000.2

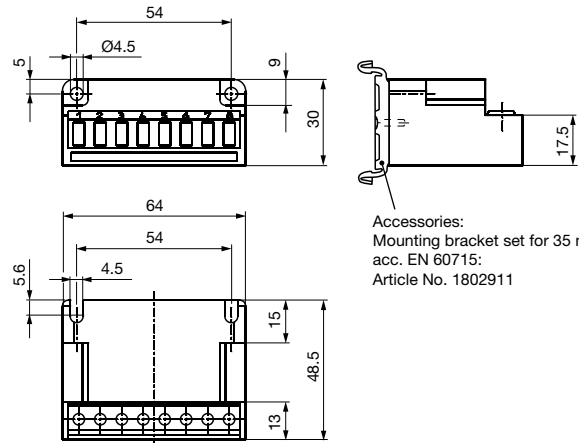

Accessories:
Mounting bracket set for 35 mm rail
acc. EN 60715:
Article No. 1802911

Type 017.100.2

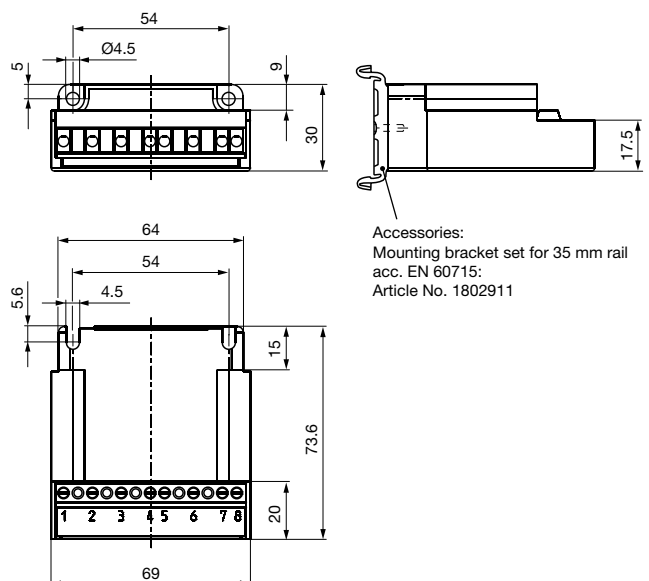

Accessories:
Mounting bracket set for 35 mm rail
acc. EN 60715:
Article No. 1802911

ROBA[®]-switch Type 017.110.2

Application

ROBA[®]-switch fast acting rectifiers are used to connect DC consumers to alternating voltage supplies, for example electromagnetic brakes and clutches (ROBA-stop[®], ROBA[®]-quick, ROBATIC[®]) as well as electromagnets, electrovalves, etc.

Fast acting rectifier ROBA[®]-switch 017.110.2

- Integrated DC-side disconnection (shorter connection time t_1)
- Consumer operation with overexcitation or power reduction
- Input voltage: 100 – 500 VAC
- Maximum output current I_{RMS} : 1.5 A
- UL-approved



The ROBA[®]-switch with integrated DC-side disconnection is not suitable for being the only safety disconnection in applications!

Function

The ROBA[®]-switch is used for operation at an input voltage of between 100 and 500 VAC, depending on the size. They can switch internally from bridge rectification U_o output voltage to half-wave rectification U_H output voltage. The bridge rectification time can be modified from 0.05 to 2 seconds by exchanging the external resistor (R_{ext}).

Apart from this, the ROBA[®]-switch has an integrated DC-side disconnection. In contrast to the usual DC-side disconnection, no further protective measures or external components are required. The DC-side disconnection is activated in standard mode (terminals 3 and 4 are not wired) and causes short switching times on the electromagnetic consumer.

The integrated DC-side disconnection is deactivated by fitting a bridge between the terminals 3 and 4. The coil is de-energised via the freewheeling diode. This has the advantages of softer braking and a lower switching noise. However, this substantially lengthens the switching times (approx. 6 – 10x).

Electrical Connection (Terminals)

- 1 + 2 Input voltage (fitted protective varistor)
- 3 + 4 Switching between DC- and AC-side disconnection
- 5 + 6 Output voltage (fitted protective varistor)
- 7 + 8 R_{ext} for bridge rectification time adjustment

Technical Data

Input voltage	see Table 1
Output voltage	see Table 1
Protection	IP65 components, IP20 terminals, IP10 R_{ext}
Terminal nom. cross-section	1.5 mm ² (AWG 22-14)
Ambient temperature	-25 °C up to +70 °C
Storage temperature	-40 °C up to +70 °C

Order Number

— / 0 1 7 . 1 1 0 . 2



Size
10
20

Dimensions (mm)

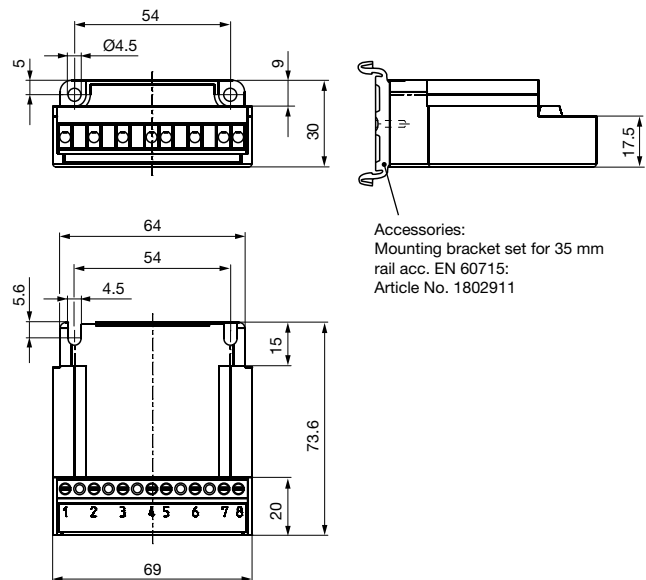

ROBA[®]-switch Sizes, Table 1

			Size	
			10	20
Input voltage ± 10 %	U_i	[VAC]	100 – 250	200 – 500
Output voltage	U_o	[VDC]	90 – 225	180 – 450
	U_H	[VDC]	45 – 113	90 – 225
Output current	at ≤ 45 °C	I_{RMS}	[A]	1.5
	at max. 70 °C	I_{RMS}	[A]	0.75
Conformity markings			UL US CE	UL US CE

ROBA®-switch 24V Type 018.000.2

Application

ROBA®-switch 24V fast switching modules are used to operate DC consumers with overexcitation or power reduction, for example electromagnetic brakes and clutches (ROBA-stop®, ROBA®-quick, ROBATIC®), electromagnets, electrovalves, etc.

Fast switching module ROBA®-switch 24V 018.000.2

- Consumer operation with overexcitation or power reduction
- Integrated DC-side disconnection (shorter connection time t_c)
- Input voltage: 24 VDC
- Max. output current I_{RMS} : 2.5 A

CAUTION



The ROBA®-switch 24V with integrated DC-side disconnection is not suitable for being the only safety disconnection in applications!

Function

The ROBA®-switch 24V units are used for an input voltage of 24 VDC. They can switch internally, meaning that the output voltage switches to holding voltage from the input voltage (= overexcitation voltage) via pulse-width modulation using 20 kHz. The overexcitation time and holding voltage can be switched.

Electrical Connection (Terminals)

- 1 Control input
- 2 + 3 Input voltage, ground
- 4 + 5 Input voltage +24V
- 6 Output voltage +
- 7 Output voltage -
- 8 + 9 Selection of overexcitation time
- 9 + 10 Selection of holding voltage

Technical Data

Input voltage U_i	24 VDC (18 – 32 VDC) SELV/PELV
Output voltage U_o	Input voltage U_i
Output voltage U_H	see Table 1
Output current I_{RMS} at $\leq 45^\circ\text{C}$	2.5 A
Output current I_{RMS} at max. 70°C	1.25 A
Protection	IP65 components, IP20 terminals
Terminal nominal cross-section	1.5 mm ² (AWG 22-14)
Ambient temperature	-25 °C up to +70 °C
Storage temperature	-40 °C up to +70 °C



Dimensions (mm)

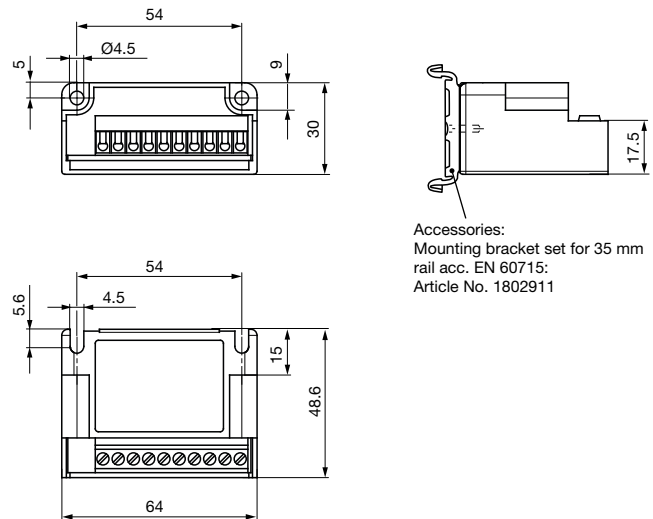

Accessories:
Mounting bracket set for 35 mm rail acc. EN 60715:
Article No. 1802911

ROBA®-switch 24V, Table 1

Article number	Overexcitation time t_o [ms]		Holding voltage U_H [VDC]	
	without	with	without	with
8237581	Bridge 8+9		Bridge 9+10	
	450	150	$\frac{1}{2} \times U_i$	$\frac{2}{3} \times U_i$

Order Number

_ / 0 1 8 . 0 0 0 . 2
 Size
 1

Example:

Order number 1 / 018.000.2 and article number 8237581

ROBA®-switch 24V Type 018.100.2



Application

ROBA®-switch 24V fast switching modules are used to operate DC consumers with overexcitation or power reduction, for example electromagnetic brakes and clutches (ROBA-stop®, ROBA®-quick, ROBATIC®), electromagnets, electrovalves, etc.

Fast switching module ROBA®-switch 24V 018.100.2

- Consumer operation with overexcitation or power reduction
- Integrated DC-side disconnection (shorter connection time t_1)
- Input voltage: 24 VDC
- Max. output current I: 5 A
- UL-approved



CAUTION



The ROBA®-switch 24V with integrated DC-side disconnection is not suitable for being the only safety disconnection in applications!

Function

The ROBA®-switch 24V units are used for an input voltage of 24 VDC. They can switch internally, meaning that the output voltage switches to holding voltage from the input voltage (=overexcitation voltage) via pulse-width modulation using 20 kHz. The overexcitation time can be adjusted via a DIP switch to 150 ms, 450 ms, 1 s, 1.5 s and 2.15 s. The holding voltage can be adjusted via a further DIP switch to $\frac{1}{4}$, $\frac{1}{3}$, $\frac{1}{2}$ and $\frac{2}{3}$ of the input voltage (equals 6 V, 8 V, 12 V and 16 V at an input voltage of 24 V).

Apart from this, the ROBA®-switch 24V has an integrated DC-side disconnection. In contrast to the usual DC-side disconnection, no further protective measures or external components are required. The DC-side disconnection is activated in standard mode and causes short switching times on the electromagnetic consumer. This can, however, be deactivated by installing a bridge between terminals 7 and 8 in order to produce soft brakings and quieter switching noises. However, this substantially lengthens the switching times (approx. 6 – 10x).

Dimensions (mm)

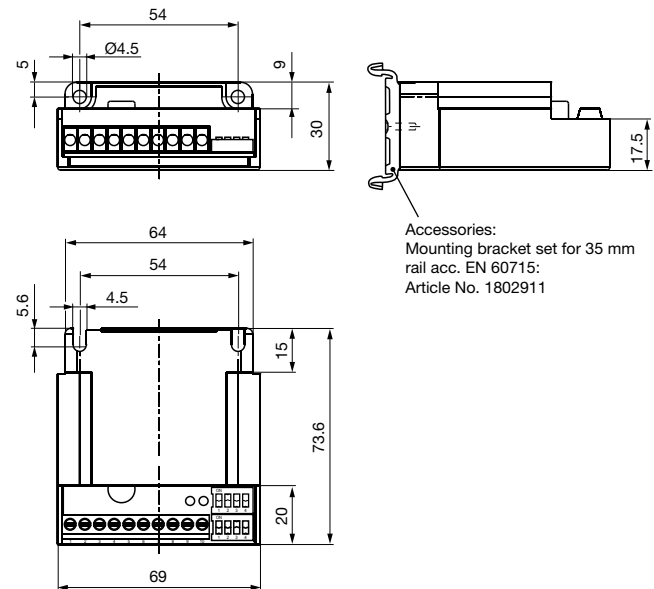

Electrical Connection (Terminals)

- 2 + 3 Input voltage, ground
- 4 Control input
- 5 – 7 Input voltage + 24 VDC
- 8 + 9 Output voltage +
- 10 Output voltage -

Technical Data

Input voltage U_i	24 VDC + 20 % / - 10 % SELV/PELV
Output voltage U_o	Input voltage U_i
Output voltage U_H	$\frac{1}{4}$, $\frac{1}{3}$, $\frac{1}{2}$, $\frac{2}{3} \times U_i \pm 20 \%$ can be selected via a DIP switch
Output current I_{RMS} at $\leq 45^\circ\text{C}$	5.0 A
Output current I_{RMS} at max. 70°C	2.5 A
Protection	IP00
Terminal nominal cross-section	1.5 mm ² (AWG 22-14)
Ambient temperature	-25 °C up to +70 °C
Storage temperature	-40 °C up to +70 °C

Order Number

— / 0 1 8 . 1 0 0 . 2



Size
1

ROBA®-brake-checker Type 028.100.2

Application

ROBA®-brake-checker monitoring modules are used to operate safety brakes with overexcitation while at the same time monitoring the condition.

Monitoring module ROBA®-brake-checker 028.100.2

- Consumer operation with overexcitation or power reduction
- Controlled output voltage (on reduction)
- Simple adjustment of holding voltage and overexcitation time via a DIP switch
- Fast or slow switch off
- Brake condition recognition (release and drop-out recognition)
- Wear recognition and error recognition
- Wide input voltage range
- Maximum output current I_{RMS} : 10 A / 5 A
- Maximum overexcitation current I_o = 20 A / 10 A
- Automatic reduction of the holding voltage U_H



CAUTION



The ROBA®-brake-checker with integrated DC-side disconnection is not suitable for being the only safety disconnection in applications!

Function

The ROBA®-brake-checker monitoring module is intended for use with an input voltage of 24 or 48 VDC. The module monitors the switching condition of the brake and emits a signal to provide information on the respective switching condition. Critical conditions (line breakages, wear) can be recognised and the respective signal can be emitted via the warning signal output.

Switching of the output voltage to a controlled holding voltage (see "Table 1") is available as an option.

After a brake-specific overexcitation time period, the integrated automatic mode adjusts to the pre-set reduction voltage. The automatic mode can be switched off using a DIP switch.

Dimensions (mm)

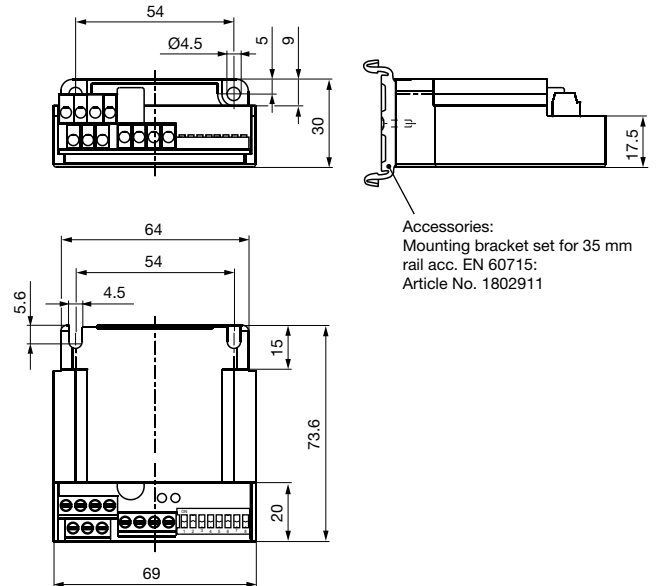

Electrical Connection (Terminals)

Power Terminal

- 1 Supply voltage +24 VDC / +48 VDC
- 2 Output voltage +
- 3 Output voltage -
- 4 Supply voltage 0 VDC



Signal Terminal

- 1 Supply voltage 0 VDC
- 2 Switch-off fast/slow (input)
- 3 Signal output (release monitoring)
- 4 24 V (auxiliary voltage for bridging)
- 5 Supply voltage +24 VDC
- 6 Start (input)
- 7 Error output max. 300 mA

Technical Data

Input voltage	see Table 1
Output voltage	see Table 1
Protection	IP65 components, IP20 terminals, IP20 DIP switch
Terminal nominal cross-section	
Power terminals	4 mm ² , (AWG 20-12)
Signal terminals	1.5 mm ² , (AWG 30-14)
Ambient temperature	-25 °C up to +70 °C
Storage temperature	-40 °C up to +105 °C

ROBA®-brake-checker Sizes, Table 1

			Size	
			2	4
			24 VDC	48 VDC
Input voltage, power terminal	SELV/PELV	U_i [VDC]	18 – 30	42 – 54
Input voltage, signal terminal		U_i [VDC]	24 (19 – 28)	
Output voltage	$\pm 5\%$	U_o [VDC]	Input voltage U_i	
	$\pm 5\%$	U_H [VDC]	6 8 12 16	12 16 24 32
Output current	at $\leq 45\text{ °C}$	I_{RMS} [ADC]	10.0	5.0
	at max. 70 °C	I_{RMS} [ADC]	5.0	2.5
Conformity markings				

Order Number

— / 0 2 8 . 1 0 0 . 2



Size
2
4

ROBA®-multiswitch Type 019._00.2



Application

ROBA®-multiswitch fast acting rectifiers are used to connect DC consumers to alternating voltage supplies, for example electromagnetic brakes and clutches (ROBA-stop®, ROBA®-quick, ROBATIC®) as well as electromagnets, electrovalves, etc.

Fast acting rectifier ROBA®-multiswitch 019._00.2

- Consistently controlled output voltage in the entire input voltage range
- Consumer operation with overexcitation or power reduction
- Input voltage: 100 – 500 VAC
- Max. output current I_{RMS} : 2 A; 4.5 A
- UL-approved



ROBA®-multiswitch units are not suitable for all applications, e.g. use of the ROBA®-multiswitch when operating noise-damped brakes is not possible without taking additional measures. The product's suitability should be checked before use.

Function

The ROBA®-multiswitch is used for operation at an input voltage of between 100 and 500 VAC, depending on the size. After switch-on, it emits the rectified bridge voltage for 50 ms and then adjusts automatically to a pre-programmed overexcitation voltage. After the overexcitation time ends, it regulates to the permanently programmed holding voltage. For the overexcitation voltage and holding voltage values of the standard design, please see Table 1. On special designs, deviating values are possible. The overexcitation time can be adjusted via a DIP switch to 150 ms, 450 ms, 1 s, 1.5 s and 2 s.

Electrical Connection (Terminals)

- 1 + 2 Input voltage (fitted protective varistor)
- 3 + 4 Connection for external contact for DC-side switch-off
- 5 + 6 Output voltage (fitted protective varistor)

Technical Data

Input voltage	see Table 1
Frequency	50 – 60 Hz
Output voltage	see Table 1
Output current	
Type 019.100.2	2 A at ≤ 45 °C; 1 A at max. 70 °C
Type 019.200.2	4.5 A at ≤ 45 °C; 2.25 A at max. 70 °C
Protection	IP65 components, IP20 terminals, IP20 DIP switch
Terminal nominal cross-section	1.5 mm ² (AWG 22-14)
Ambient temperature	-25 °C up to +70 °C
Storage temperature	-40 °C up to +70 °C

Order Number

__	/	0	1	9	.	__	0	0	.	2
▲						▲				
Size		1			max. 2.0 A I_{RMS}		2			max. 4.5 A I_{RMS}
10										
20										

Example:

Order number 20 / 019.100.2 and article number 8225580

Dimensions (mm)

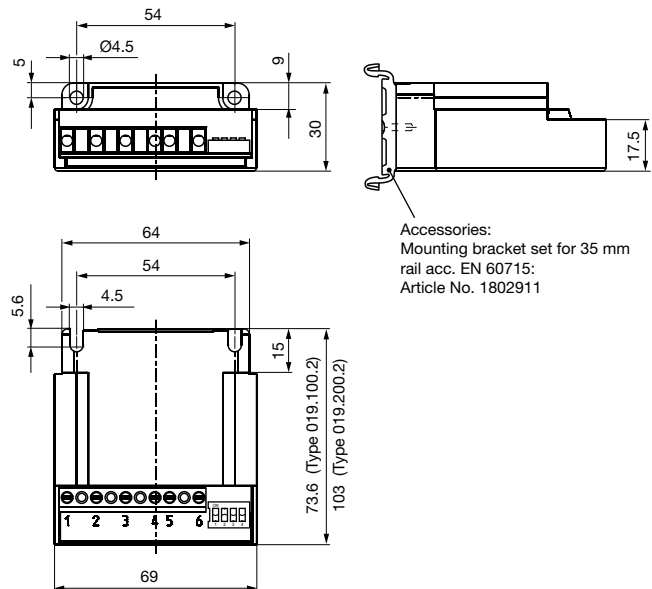

ROBA®-multiswitch Sizes, Table 1

Size	Type	Input voltage * ± 10 % acc. EN 50160 [VAC]	Output voltage * ± 10 %		Article number
			U_o^{**} [VDC]	U_H^{**} [VDC]	
10	019.100.2	100 – 275	90	52	8186586
	019.200.2	200 – 500	180	104	8242954
20	019.100.2	230	207	30	8225580
	019.200.2	230	207	30	8237887
	019.100.2	300 – 500	240	52	8220914

* On special designs, deviating values are possible. The values stated on the Type tag are decisive.

** U_o : overexcitation voltage; U_H : holding voltage

Spark Quenching Unit Type 070.000.6

Application

Reduces spark production on the switching contacts occurring during DC-side switch-off of inductive loads.

- Voltage limitation according to VDE 0580 2000-07, Item 4.6.
- Reduction of EMC-disturbance by voltage rise limitation, suppression of switching sparks.
- Reduction of brake engagement times by a factor of 2 – 4 compared to freewheeling diodes.

Function

The spark quenching unit will absorb voltage peaks resulting from inductive load switching, which can cause damage to insulation and contacts. It limits these to 70 V and reduces the contact load. Switching products with a contact opening distance of > 3 mm are suitable for this purpose.

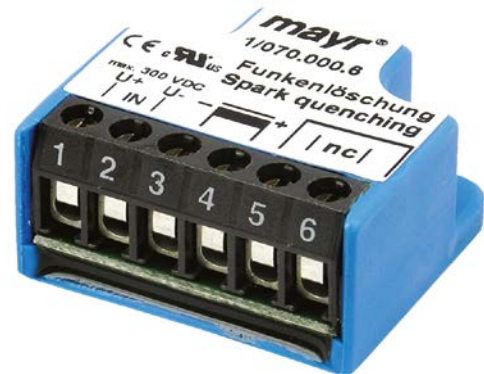

Electrical Connection (Terminals)

- | | |
|-------|------------------|
| 1 (+) | Input voltage |
| 2 (-) | Input voltage |
| 3 (-) | Coil |
| 4 (+) | Coil |
| 5 | Free nc terminal |
| 6 | Free nc terminal |

Technical Data

Input voltage	max. 300 VDC, max. 615 V _{peak} (rectified voltage 400 VAC, 50/60 Hz)
Switch-off energy	max. 9 J / 2 ms
Power dissipation	max. 0.1 Watt
Rated voltage	
nc terminals	250 V
Protection	IP65 components, IP20 terminals
Ambient temperature	-25 °C up to +85 °C
Storage temperature	-40 °C up to +85 °C
Max. conductor connection diameter	2.5 mm ² / AWG 26-12
Max. terminal tightening torque	0.5 Nm

Dimensions (mm)

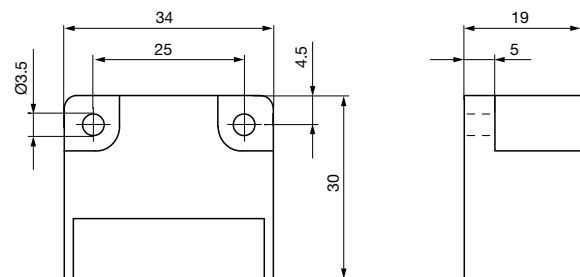

Accessories

Mounting bracket set for 35 mm rail acc. EN 60715:
Article No. 1803201

Order Number

— / 0 7 0 . 0 0 0 . 6



Size
1

ROBA®-SBCplus

The safe brake control - for use up to PLe and SIL CL3

Application

The safe brake control ROBA®-SBCplus is used to control and monitor two ROBA-stop® safety brakes, especially in applications, which have to fulfill requirements regarding person protection according to the standards for functional reliability, such as for example ISO 13849 and IEC 62061.

Characteristics:

- Safe electronic switching of two brakes
- Input voltage power circuit 24 - 48 VDC
- Connection for up to 2 brakes up to 4.5 A / 24 VDC or 2.25 A / 48 VDC (108 W)
- Output voltage (holding voltage) can be selected 6,8,12,24,48 VDC
 - Power reduction, temperature reduction, electricity costs reduction
- Overexcitation time configurable
- Feedback inputs release monitoring for proximity switch or microswitch
- Monitoring for plausibility of the feedback
 - Error diagnostics of the brake
- Status and error outputs for feedback to the control
- No mechanic contacts for controlling and monitoring
 - High reliability, no wear, independent of cycle frequency and cycle rate
- Fast (“DC-side”) or slow (“AC-side”) switch off possible
- Galvanic separation between the control part and the power part
 - Prevention of EMC issues
- Four integrated functions: Contactor, 24 VDC fast-acting rectifier, safety relay, spark quenching
- Safe holding voltage and overexcitation time
- Safety functions are programmed into the ROBA®-SBCplus and only have to be parameterised
 - Plausibility check integrated and must not be programmed and validated
- Applicable up to PLe and SIL CL3, Type examination TÜV Süd (German Technical Inspectorate)



Maximum switching reliability

The brake control must safely interrupt the current in the magnetic coil on switching off the brake. The ROBA®-SBCplus module works with wear-free electronic semiconductors and thus achieves almost unlimited switching frequencies and switching reliability.

Safe inner configuration

Amongst other things, the internal diagnostics inspections for short circuits, earth short-circuits and line breaks as well as safe overexcitation for releasing the brake and switching to reduced holding voltage when the brake is opened are the components required for “fail-safe” inner configuration.

Numerous safety functions

Numerous safety functions permit comprehensive error diagnostics. The brake voltage is monitored. An excessively high voltage could dangerously extend the drop-out time on switch-off, if, for example, this were to cause a vertical axis to drop to an unpermittedly low level. The monitoring of the switching times, which influence the braking distance, is therefore another component of error diagnostics.

Safe switching condition monitoring

The signal evaluation of the release monitoring with plausibility check permits a switching condition monitoring of the brake. The plausibility is controlled as follows: If voltage is applied, the brake must be opened after a defined time and vice versa. The switching condition monitoring can be used to reliably prevent the drive starting up against a closed brake. In this way, creeping errors, such as gradually increasing wear, which affects the switching times, can be detected.

ROBA®-torqcontrol

Adapted braking -

Intelligent braking torque control module

In contrast to car brakes, safety brakes can only distinguish between two operating conditions due to their design, namely “braking torque present” and “no braking torque present”. This is the reason why every braking procedure is carried out with the maximum braking torque available. Just as in a car, gradual, even deceleration is also often desired for devices and machine applications with dynamic braking actions. The new, intelligent braking torque control module **ROBA®-torqcontrol** by *mayr*® power transmission therefore offers an economically attractive solution to generate a variable braking torque for ROBA-stop® safety brakes, making it possible to decelerate machines evenly and gently.



Continuous braking torque changes when in operation

Up to now, brakes have been dimensioned with regard to the maximum load where devices with variable loads, for example forklift trucks, are concerned. In case of partial loads, a stronger deceleration than necessary with the full braking torque can lead to damage to the transported goods or even to sliding of the wheels. If, however, the system detects the operating conditions and converts this information into a default signal for the new, intelligent control module by *mayr*® power transmission, electronic braking torque regulation is possible. Using the new system, the brake specialists have succeeded in continuously changing the contact force on the brake linings and therefore also the braking torque during operation. In this way, machines can be decelerated smoothly, adapted to the respective system requirements. Using the new, intelligent control device by *mayr*® power transmission, the resulting clamping force for the brake rotor can be specified to 25%, 50% or 75% of

the nominal spring force by means of two digital inputs. Alternatively, a continuous, analogue default signal from 0 to 10 V is possible. The switching device determines without using a sensor whether the armature disk is attracted or has dropped. This makes it possible to adjust the overexcitation time automatically as desired. With the new braking torque control module, *mayr*® power transmission provide the possibility to build up control circuits and brake movements intelligently – ideal prerequisites for application in the smart, interconnected machines of the future.

Technical Data

	Intelligent braking torque control module ROBA®-torqcontrol
Supply voltage	24 V or 48 V
Output current	10 A or 5 A
Inputs	Start/Stop
	digital braking torque pre-selection 25%, 50%, 75% or analogue 0...10 V equals 25...100% torque
Outputs	release signal
Adjustable voltage reduction/overexcitation	√
Automatic overexcitation time or manually adjustable	√
Release and drop recognition for safety brakes	√
Dimensions L x W x H	103 x 69 x 30 mm

Additional Information



The catalogue contains basic information on pre-selection and dimensioning.

For detailed information on selection, brake dimensioning, electrical connection, installation and initial operation, please see the Installation and Operational Instructions B.8.1.

If you have any questions regarding the selection and dimensioning, please contact our headquarters.

Safety-relevant Applications

Brakes which are used in safety-related applications are to be selected in accordance with the risk assessment EN ISO 12100 and furthermore in accordance with EN ISO 13849-1 through identification of the safety function.

This is in principle the task of the system manufacturer.

Roba-stop[®]-M standard designs with safety parameters:

- Type 891.10_._ nominal torque holding brake
- Type 891.01_._ 100% nominal torque standard
- Type 891.02_._ 84% nominal torque
- Type 891.02_._ 68% nominal torque
- Type 891.01_._ 112% nominal torque standard
- Type 891.01_._ 125% nominal torque standard

Customer-specific designs on request.

Safety parameters can be requested if required.

In case of deviating designs, please consult with mayr[®] power transmission directly.

Secure Control acc. EN ISO 13849-1

For safe control, a brake control module specially developed for such applications, is available. According to SIL 3 Level, two brake circuits can be supplied. **For detailed information please see page 24.**

Additional Supply and Control Modules

For controlling the **Roba-stop[®]-M**, additional suitable supply and control modules are available.

For overview and functions, please see page 15.

The **Catalogue K.001.V_ _ "Reliable control of DC consumers"** features a detailed description of the different modules.

Available quickly as PDF download.

We would be happy to mail you a printed version of the Installation and Operational Instructions B.8.1 and catalogue K.001.V_ _ _ _ on request.

These documents are also available as **PDF download** on our website **www.mayr.com**.

ROBA-stop®-M – Guidelines



Guidelines on the Declaration of Conformity: A conformity evaluation has been carried out for the product (electromagnetic safety brake) in terms of the EC Low Voltage Directive 2006/95/EC. The Declaration of Conformity is laid out in writing in a separate document and can be requested if required.

Guidelines on the EMC Directive (2004/108/EC): The product cannot be operated independently according to the EMC directive.

Due to their passive state, brakes are also non-critical equipment according to the EMC. Only after integration of the product into an overall system can this be evaluated in terms of the EMC. For electronic equipment, the evaluation has been verified for the individual product in laboratory conditions, but not in the overall system.

Guidelines on the Machinery Directive (2006/42/EC): The product is a component for installation into machines according to the machinery directive 2006/42/EC. The brakes can fulfil the specifications for safety-related applications in coordination with other elements. The type and scope of the required measures result from the machine risk analysis. The brake then becomes a machine component and the machine manufacturer assesses the conformity of the safety device to the directive. It is forbidden to start use of the product until you have ensured that the machine accords with the regulations stated in the directive.

Guidelines on the ATEX Directive: Without a conformity evaluation, this product is not suitable for use in areas where there is a high danger of explosion. For application of this product in areas where there is a high danger of explosion, it must be classified and marked according to directive 94/9/EC.

Safety Regulations

Brakes may generate several risks, among others:



During the risk assessment required when designing the machine or system, the dangers involved must be evaluated and removed by taking appropriate protective measures.

To prevent injury or damage, only professionals and specialists are allowed to work on the devices. They must be familiar with the dimensioning, transport, installation, initial operation, maintenance and disposal according to the relevant standards and regulations.

Application Conditions



The catalogue values are guideline values which have been determined in test facilities. It may be necessary to carry out your own tests for the intended application.

When dimensioning the brakes, please remember that installation situations, braking torque fluctuations, permitted friction work, run-in behaviour and wear as well as general ambient conditions can all affect the given values. These factors should therefore be carefully assessed, and alignments made accordingly.

- Mounting dimensions and connection dimensions must be adjusted according to the size of the brake at the place of installation.
- The magnetic coils are designed for a relative duty cycle of 100%, if no other values are stated.
- The braking torque is dependent on the present run-in condition of the brake.
- The brakes are only designed for dry running. The torque is lost if the friction surfaces come into contact with oil, grease, water or similar substances or foreign bodies.
- Manufacturer-side corrosion protection of the metallic surfaces.
- The rotors may rust up and block in corrosive ambient conditions and/or after long periods of storage.

Ambient Temperature: –20 °C up to +40 °C

Protection

(mechanical) IP54: When installed, dust-proof and protected against contact as well as against water spray from any direction (dependent on customer-side mounting method).

(electrical) IP54: Dust-proof and protected against contact as well as against water spray from any direction.

IP65 (Type 891..._1): Dust-proof and protected against contact as well as against jet water from a nozzle coming from any direction.

Earthing Connection

The brake is designed for Protection Class I. This protection covers not only the basic insulation, but also the connection of all conductive parts to the protective conductor (PE) on the fixed installation. If the basic insulation fails, no contact voltage will remain. Please carry out a standardised inspection of the protective conductor connections to all contactable metal parts!

Intended Use

mayr®-brakes have been developed, manufactured and tested in compliance with the VDE 0580 standard and in accordance with the EU Low Voltage Directive as electromagnetic components. During installation, operation and maintenance of the product, the standard requirements must be observed. mayr®-brakes are for use in machines and systems and must only be used in the situations for which they are ordered and confirmed. Using them for any other purpose is not allowed.

Guidelines for Electromagnetic Compatibility (EMC)

In accordance with the EMC directives 2004/108/EC, the individual components produce no emissions. However, functional components e.g. mains-side energisation of the brakes with rectifiers, phase demodulators, ROBA®-switch devices or similar controls can produce disturbance which lies above the allowed limit values. For this reason it is important to read the Installation and Operational Instructions very carefully and to keep to the EMC directives.

Standards, Directives and Regulations Used

VDE 0580	Electromagnetic devices and components, general specifications
2006/95/EC	Low Voltage Directive
CSA C22.2 No. 14-2010	Industrial Control Equipment
UL 508 (Edition 17)	Industrial Control Equipment
EN ISO 12100	Safety of machinery - General principles for design - Risk assessment and risk reduction
EN 61000-6-4	Interference emission
EN 61000-6-2	Interference immunity
EN 60204-1	Electrical equipment of machines

Liability

- The information, guidelines and technical data in these documents were up to date at the time of printing. Demands on previously delivered brakes are not valid.
- Liability for damage and operational malfunctions will not be taken if: the Installation and Operational Instructions are ignored or neglected, the brakes are used inappropriately, the brakes are modified, the brakes are worked on unprofessionally and the brakes are handled or operated incorrectly.

Guarantee

- The guarantee conditions correspond with the Chr. Mayr GmbH + Co. KG sales and delivery conditions.
- Mistakes or deficiencies are to be reported to mayr® at once!

Service Germany

Baden-Württemberg
Esslinger Straße 7
70771 Leinfelden-Echterdingen
Tel.: 07 11/45 96 01 0
Fax: 07 11/45 96 01 10

Bavaria
Eichenstraße 1
87665 Mauerstetten
Tel.: 0 83 41/80 41 04
Fax: 0 83 41/80 44 23

Chemnitz
Bornaer Straße 205
09114 Chemnitz
Tel.: 03 71/4 74 18 96
Fax: 03 71/4 74 18 95

Franken
Unterer Markt 9
91217 Hersbruck
Tel.: 0 91 51/81 48 64
Fax: 0 91 51/81 62 45

Hagen
Im Langenstück 6
58093 Hagen
Tel.: 0 23 31/78 03 0
Fax: 0 23 31/78 03 25

Kamen
Lünener Straße 211
59174 Kamen
Tel.: 0 23 07/23 63 85
Fax: 0 23 07/24 26 74

North
Schiefer Brink 8
32699 Extertal
Tel.: 0 57 54/9 20 77
Fax: 0 57 54/9 20 78

Rhine-Main
Hans-Böckler-Straße 6
64823 Groß-Umstadt
Tel.: 0 60 78/7 82 53 37
Fax: 0 60 78/9 30 08 00

Branch office

China
Mayr Zhangjiagang
Power Transmission Co., Ltd.
Chenxin Road No.7,
215637 Zhangjiagang
Tel.: 05 12/58 91-75 67
Fax: 05 12/58 91-75 66
info@mayr-ptc.cn

Great Britain
Mayr Transmissions Ltd.
Valley Road, Business Park
Keighley, BD21 4LZ
West Yorkshire
Tel.: 0 15 35/66 39 00
Fax: 0 15 35/66 32 61
sales@mayr.co.uk

France
Mayr France S.A.S.
Z.A.L. du Minopole
Rue Nungesser et Coli
62160 Bully-Les-Mines
Tel.: 03.21.72.91.91
Fax: 03.21.29.71.77
contact@mayr.fr

Italy
Mayr Italia S.r.l.
Viale Veneto, 3
35020 Saonara (PD)
Tel.: 0498/79 10 20
Fax: 0498/79 10 22
info@mayr-italia.it

Singapore
Mayr Transmission (S) PTE Ltd.
No. 8 Boon Lay Way Unit 03-06,
TradeHub 21
Singapore 609964
Tel.: 00 65/65 60 12 30
Fax: 00 65/65 60 10 00
info@mayr.com.sg

Switzerland
Mayr Kupplungen AG
Tobelackerstraße 11
8212 Neuhausen am Rheinfall
Tel.: 0 52/6 74 08 70
Fax: 0 52/6 74 08 75
info@mayr.ch

USA
Mayr Corporation
4 North Street
Waldwick
NJ 07463
Tel.: 2 01/4 45-72 10
Fax: 2 01/4 45-80 19
info@mayrcorp.com

Representatives

Australia
Regal Beloit Australia Pty Ltd.
19 Corporate Ave
03178 Rowville, Victoria
Australien
Tel.: 0 3/92 37 40 00
Fax: 0 3/92 37 40 80
salesAUvic@regalbeloit.com

India
National Engineering
Company (NENCO)
J-225, M.I.D.C.
Bhosari Pune 411026
Tel.: 0 20/27 13 00 29
Fax: 0 20/27 13 02 29
nenco@nenco.org

Japan
MATSUI Corporation
2-4-7 Azabudai
Minato-ku
Tokyo 106-8641
Tel.: 03/35 86-41 41
Fax: 03/32 24 24 10
k.goto@matsui-corp.co.jp

Netherlands
Groneman BV
Amarilstraat 11
7554 TV Hengelo OV
Tel.: 074/2 55 11 40
Fax: 074/2 55 11 09
aandrijftechniek@groneman.nl

Poland
Wamex Sp. z o.o.
ul. Pozaryskiego, 28
04-703 Warszawa
Tel.: 0 22/6 15 90 80
Fax: 0 22/8 15 61 80
wamex@wamex.com.pl

South Korea
Mayr Korea Co. Ltd.
15, Yeondeok-ro 9beon-gil
Seongsan-gu
51571 Changwon-si
Gyeongsangnam-do, Korea
Tel.: 0 55/2 62-40 24
Fax: 0 55/2 62-40 25
info@mayrkorea.com

Taiwan
German Tech Auto Co., Ltd.
No. 28, Fenggong Zhong Road,
Shengang Dist.,
Taichung City 429, Taiwan R.O.C.
Tel.: 04/25 15 05 66
Fax: 04/25 15 24 13
abby@zfgta.com.tw

Czech Republic
BMC - TECH s.r.o.
Hviezdoslavova 29 b
62700 Brno
Tel.: 05/45 22 60 47
Fax: 05/45 22 60 48
info@bmc-tech.cz

More representatives:

Austria, Belgium, Brazil, Canada, Denmark, Finland, Greece, Hongkong, Hungary, Indonesia, Israel, Luxembourg, Malaysia, New Zealand, Norway, Philippines, Romania, Russia, Slovakia, Slovenia, South Africa, Spain, Sweden, Thailand, Turkey

You can find the complete address for the representative responsible for your area under www.mayr.com in the internet.