

Installation and Operational Instructions for EAS[®] - HTL housed overload clutch Sizes 01 – 3 Type 490._24.0

(B.4.15.1.EN)

Please read these Operational Instructions carefully and follow them accordingly!

Ignoring these Instructions may lead to malfunctions or to clutch failure, resulting in damage to other parts.

Contents:

- Page 1:** - Contents
- Safety Regulations
- Safety and Guideline Signs
- Page 2:** - Clutch Illustration
- Page 3:** - Parts List
- Technical Data
- Page 4:** - Technical Data
- Page 5:** - Design
- Scope of Delivery / State of Delivery
- Function
- General Installation Guidelines
- Page 6:** - Installation Preparations
- Installation
- Re-engagement
- Page 7:** - Torque Adjustment
- Page 8:** - Limit Switch
- Maintenance
- Disposal
- Page 9:** - Malfunctions / Breakdowns

Safety and Guideline Signs

CAUTION



Danger of injury to personnel and damage to machines.



Please Observe!
Guidelines on important points.



According to German notation, decimal points in this document are represented with a comma (e.g. 0,5 instead of 0.5).

Safety Regulations

These Installation and Operational Instructions (I + O) are part of the clutch delivery. Please keep them handy and near to the clutch at all times.



It is forbidden to start use of the product until you have ensured that all applicable EU directives, directives for the machine or system into which the product has been installed have been fulfilled. At the time these Installation and Operational Instructions go to print, the EAS[®]-clutches accord with the known technical specifications and are operationally safe at the time of delivery. Without a conformity evaluation, this product is not suitable for use in areas where there is a high danger of explosion. This statement is based on the ATEX directive.

CAUTION



- If the EAS[®]-clutches are modified.
- If the relevant standards for safety and / or installation conditions are ignored.

User-implemented Protective Measures

- Cover all moving parts to protect against seizure, dust or foreign body impact.
- The clutches may not be put into operation without a limit switch unless *mayr*[®] has been contacted and has agreed otherwise.

To prevent injury or damage, only professionals and specialists should work on the devices, following the relevant standards and directives. Please read the Installation and Operational Instructions carefully before installation and initial operation of the device.

These Safety Regulations are user hints only and may not be complete!

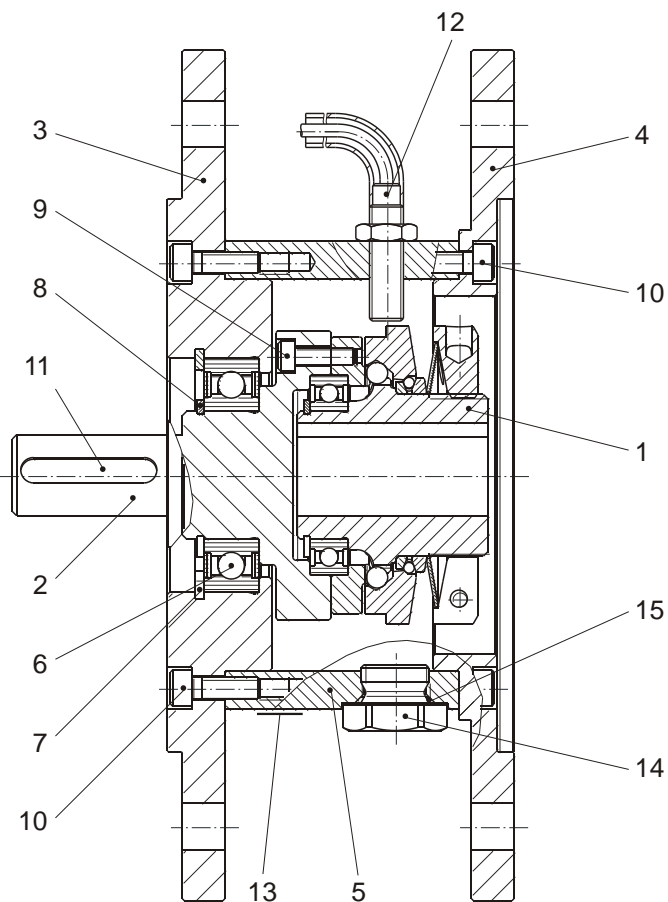

Fig. 1

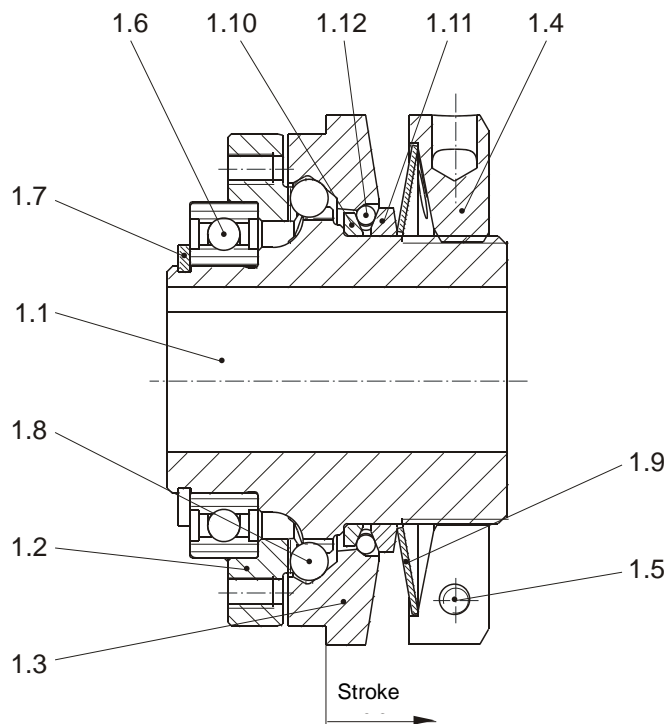

Fig. 2

Installation and Operational Instructions for EAS[®]- HTL housed overload clutch Sizes 01 – 3 Type 490._24.0

(B.4.15.1.EN)

Parts List (Only use *mayr*[®] original parts)

Item	Name
1	EAS [®] -Compact [®] overload clutch
1.1	Hub
1.2	Pressure flange
1.3	Thrust washer
1.4	Adjusting nut
1.5	Cap screw DIN EN ISO 4762
1.6	Deep groove ball bearing DIN 625
1.7	Locking ring DIN 471
1.8	Steel ball DIN 5401
1.9	Cup spring
1.10	Supporting ring
1.11	Thrust ring
1.12	Steel ball DIN 5401

Item	Name
2	Output shaft
3	Output-side flange
4	Input-side flange
5	Distance ring
6	Deep groove ball bearing DIN 625
7	Locking ring DIN 472
8	Locking ring DIN 471
9	Cap screw DIN EN ISO 4762
10	Cap screw DIN EN ISO 4762
11	Key DIN 6885/1
12	Limit switch
13	Type tag
14	Screw plug DIN 7604
15	O-ring

Technical Data

Table 1

Size	Limit torques for overload M_e				Max. speed [rpm]
	Type 490.524.0 [Nm]	Type 490.624.0 [Nm]	Type 490.724.0 [Nm]	Type 490.824.0 [Nm]	
01	5 – 12,5	10 – 25	20 – 50	25 – 62,5	8000
0	10 – 25	20 – 50	40 – 100	50 – 125	7000
1	20 – 50	40 – 100	80 – 200	100 – 250	6000
2	40 – 100	80 – 200	160 – 400	200 – 500	5000
3	80 – 200	160 – 400	320 – 800	400 – 1000	4000

Table 2

Size	Tightening torque Item 1.5 [Nm]	Tightening torque Item 9 [Nm]	Tightening torque Item 10 [Nm]	Thrust washer stroke (Fig. 2; Item 1.3) on overload [mm]	Bore from – to [mm]
01	3	4,5	5	2,0	12 – 20
0	5	9,5	5	2,6	15 – 25
1	9	16	20	3,2	22 – 30
2	9	16	20	3,8	28 – 40
3	15	40	20	4,5	32 – 50

Installation and Operational Instructions for EAS® - HTL housed overload clutch Sizes 01 – 3 Type 490._24.0

(B.4.15.1.EN)

Technical Data

Table 3

Size	Type 490.524.0		Type 490.624.0		Type 490.724.0		Type 490.824.0	
	Maximum torque M_G [Nm]	Inspection dimension "a" (Fig. 5) at approx. 70 % M_G [mm]	Maximum torque M_G [Nm]	Inspection dimension "a" (Fig. 5) at approx. 70 % M_G [mm]	Maximum torque M_G [Nm]	Inspection dimension "a" (Fig. 5) at approx. 70 % M_G [mm]	Maximum torque M_G [Nm]	Inspection dimension "a" (Fig. 5) at approx. 70 % M_G [mm]
01	12,5	4,4	25	3,7	50	2,2	62,5	1,4
0	25	4,7	50	3,8	100	1,8	125	0,8
1	50	5,1	100	4,0	200	1,5	250	0,3
2	100	6,6	200	5,3	400	2,5	500	1,1
3	200	5,0	400	3,1	800	-0,4	1000	-2,1

Table 4

Clutch size	Motor size	Dimension h [mm]	Dimension h ₂ [mm]	Maximum shaft length h ₁ [mm]	Weight [kg]
01	80	40	40	52	8,2
0	90	50	50	63	9,8
1	100	60	60	79	16,6
2	132	80	80	93	23,5
3	160	110	110	126	34
3	180	110	110	126	37
01	56C	2,06"	2,06"	2,20"	6,8
01	143TC	2,12"	2,12"	2,20"	7
1	184TC	2,87"	2,87"	3,16"	18,3
2	215TC	3,37"	3,37"	3,43"	19,8
2	256TC	4,00"	4,00"	4,20"	19

Table 5: Max. permitted bearing loads

Clutch size	Motor size	Axial forces [N]	Radial forces [N]	Transverse force torque B ¹⁾ (Fig. 3) referring to the clutch flange [Nm]	Transverse force torque C ²⁾ (Fig. 3) referring to the housing [Nm]
01	80	200	400	5	318
0	90	300	600	10	495
1	100	350	700	20	765
2	132	350	700	30	1568
3	160	500	1000	40	1872
3	180	500	1000	40	2912
01	56C	100	200	5	318
01	143TC	200	400	5	318
1	184TC	350	700	20	995
2	215TC	350	700	30	995
2	256TC	350	700	30	995



¹⁾ Value B indicates torques which put strain on the deep groove ball bearing due to the non-centric axial forces having an effect on the pressure flange.

²⁾ Value C refers to purely static loads. In case of oscillation or vibration occurrence, please use a safety factor of 2,5.

Installation and Operational Instructions for EAS[®]- HTL housed overload clutch Sizes 01 – 3 Type 490._24.0

(B.4.15.1.EN)

Design

The EAS[®]-HTL overload clutch is designed as a mechanically disengaging overload clutch, based on the ball detent principle. It is designed as a housed clutch (Protection IP 53) for attachment to an IEC B5 flange according to DIN EN 50347 or a NEMA flange. The connection dimensions are designed according to the motor sizes 80, 90, 100, 132, 160, 180, or 56 C, 143 TC, 184 TC, 215 TC and 256 TC.

EAS[®]-HTL clutches as a complete unit provide overload protection between the motor and the gearbox.

Scope of Delivery / State of Delivery

- The clutch is manufacturer-assembled ready for installation.
- The torque is set manufacturer-side according to the customer's request (please compare the torque stipulated in the order with the torque imprinted/engraved in the identification).
Unless the customer requests a particular torque setting when ordering, the clutch will be pre-set to approx. 70 % of the maximum torque.
- The limit switch has been adjusted as capable of function manufacturer-side.

Please check the scope of delivery according to the Parts List as well as the state of delivery immediately after receiving the goods.

mayr[®] will take no responsibility for belated complaints.

Please report transport damage immediately to the deliverer.

Please report incomplete delivery and obvious defects immediately to the manufacturer.

Function

The clutch protects the drive line from excessively high, unpermitted torque impacts which can occur due to unintentional blockages.

After overload has taken place, the transmitting mechanism is completely disconnected. Only the bearing friction continues to have an effect.

This means that no re-engagement impacts or metallic sliding movements occur on the clutch torque transmission geometries when using this clutch variant.

In order to make the clutch ready for operation again after an overload occurrence, the clutch must be re-engaged.

When in operation, the set torque is transmitted backlash-free onto the output from the motor shaft via the EAS[®]-Compact[®] overload clutch (pressure flange (1.2)).

If the set limit torque is exceeded (overload), the clutch disengages and remains disengaged.

The input and the output are separated residual torque-free.

A signal is emitted via the limit switch (12) which can be used to shut down the entire system or machine.

After-acting masses can run free.

CAUTION



After overload occurrence, the clutch has no load-holding function.

General Installation Guidelines

- Important!**
EAS[®]-HTL clutches do not compensate for shaft misalignments.
- Do not introduce radial / axial forces onto the clutch bearing due to component distortion.
- Minimum screw quality 8.8 for customer-side attachment.
- Please observe the max. permitted bearing loads acc. Table 5 on page 4.



The determination of the max. permitted bearing load is based on a nominal lifetime estimation of 32000 h according to the usual specifications provided by the bearing manufacturers.

Possible bearing distortion must be ruled out via temperature measurement on the housing in the deep groove ball bearing (6) area during initial operation: $\Delta T \leq 40 \text{ °C}$

The steady-state temperature must be evaluated.

Installation and Operational Instructions for EAS[®]- HTL housed overload clutch Sizes 01 – 3 Type 490_24.0

(B.4.15.1.EN)

Installation Preparations (Customer-side)

- Bore and shaft surface quality:
Ra = 1,6 µm acc. DIN EN ISO 4287.
- Shaft material: yield point at least 400 N/mm²,
e. g. St 60, St 70, C 45, C 60.
- Bore tolerance: F7
- Shaft tolerance: k6.
- Shape and position tolerances (flange geometry):
Manufactured for clutch transmission part acc. Fig. 3.

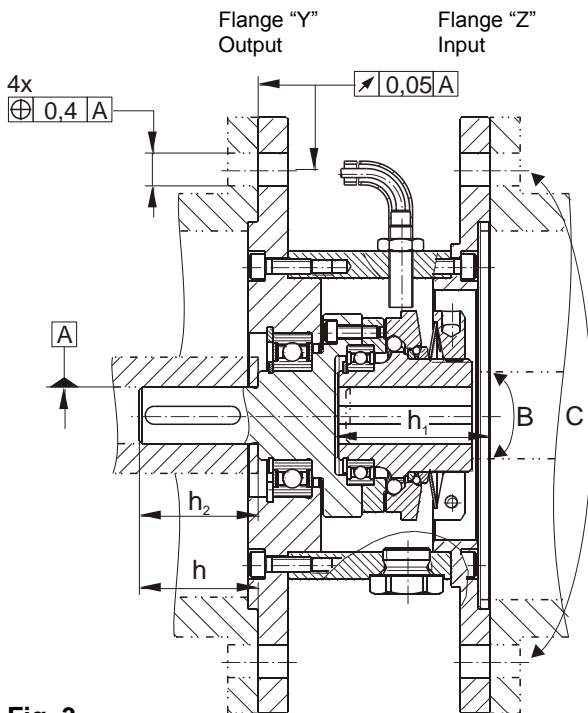

Fig. 3

Installation (Figs. 1 to 3)

- Insert the manufacturer-assembled and adjusted clutch into the customer bore or flange "Y", turn it to the correct position (must align with the fixing threads) and bolt it together with the mounting part (flange "Y") using 4 screws.



Please observe clutch dimensions h and h_2 (see Table 4 and Fig. 3).

- Insert flange "Z" with the shaft into the clutch hub bore (Item 1.1) or the flange inner centring (Item 4), turn it to the correct position (must align with the fixing holes) and bolt it together with the mounting part (flange "Z") using 4 screws.



Please observe the maximum shaft length h_1 (see Table 4 and Fig. 3).

Re-engagement (Fig. 4)



Re-engagement must only take place when the device is not running or at low differential speed (< 10 rpm).

There are two bores (180° offset to one another) for manual clutch re-engagement. They are locked with screw plugs (14). In order to re-engage the clutch, at least one of the two screw plugs (14), including its O-ring (15), must be loosened and removed. EAS[®]-Compact[®] overload clutch re-engagement is carried out by applying axial pressure to the thrust washer (1.3) in the direction of the output (flange Y) using a suitable lever tool (Fig. 4). It may be necessary to turn slightly between the pressure flange (1.2) and the thrust washer (1.3).



Please make sure that the bore threads (for screw plugs Item 14) in the distance ring (5) are not damaged by the lever tool.

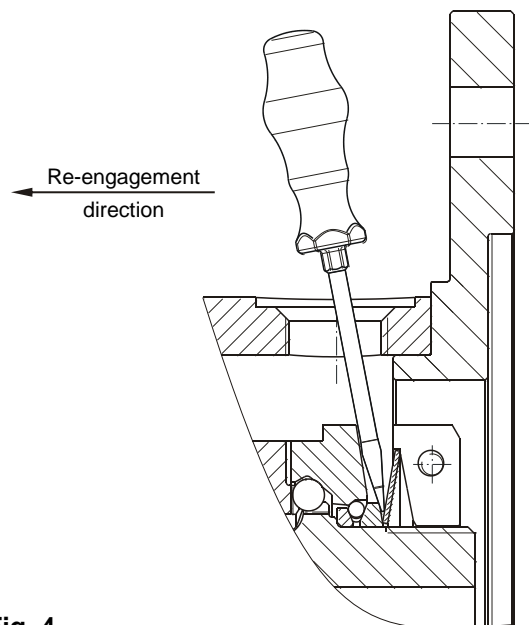

Fig. 4

After re-engagement has been completed successfully, the access bore must be re-closed using the screw plug (14) and the O-ring (15) placed under it.

Installation and Operational Instructions for EAS® - HTL housed overload clutch Sizes 01 – 3 Type 490._24.0

(B.4.15.1.EN)

Torque Adjustment

The torque is set manufacturer-side according to the customer's request.

Torque adjustment is carried out by turning the adjusting nut (1.4). The installed cup springs (1.9) are operated in the negative range of the characteristic curve (see Fig. 7); this means that a stronger pre-tensioning of the cup spring results in a decrease of the spring force.

The torque is set manufacturer-side according to the customer's request.

If no particular torque adjustment is requested customer-side, the clutch will always be **pre-set** and **marked** (calibrated) manufacturer-side to approx. 70 % of the maximum torque. It is possible to check the **"Spring operation in the operating range"** (Fig. 7) using the dimension "a" (distance from the adjusting nut (1.4) facing side to the hub (1.1) facing side, as shown in Fig. 5).

Please see Table 3 for the respective values.



Turning the adjusting nut (1.4) clockwise causes a reduction in torque.
Turning it anti-clockwise causes an increase in torque.
You should be facing the adjusting nut (1.4) as shown in Figs. 5 and 6.

Changing the Torque

- a) Please convert the required torque using the formula below into percent of the maximum adjustment value (see Table 3).

$$\frac{\text{Required torque adjustment}}{\text{max. adjustment value}} \times 100 = \text{Adjustment in \%}$$

- b) Loosen the locking screw (1.5) in the adjusting nut (1.4).
c) Turn the adjusting nut (1.4) clockwise or anti-clockwise according to the engraved adjustment scale (Fig. 6) using a hook wrench or a face wrench, until the required torque is set.
d) The required torque results from the marking overlap on the hub (1.1) and the percent value on the adjusting nut (Item 1.4 / Figs. 5 and 6).
e) Tighten the locking screw (1.5) again (please observe the tightening torque acc. Table 2).



Adjusting the adjusting nut (1.4) or distorting the cup spring (1.9) outside of the cup spring characteristic curve (see Fig. 7) stops the clutch functioning.

The inspection dimension "a" (see Table 3) can show deviations due to construction tolerances or to clutch wear.

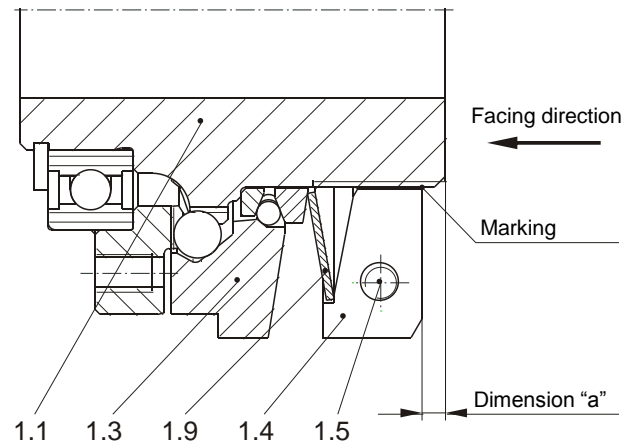

Fig. 5

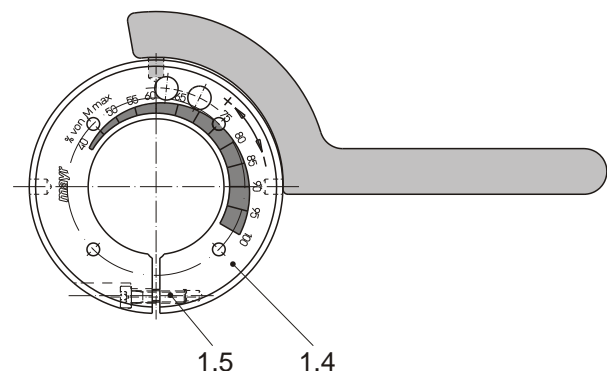

Fig. 6

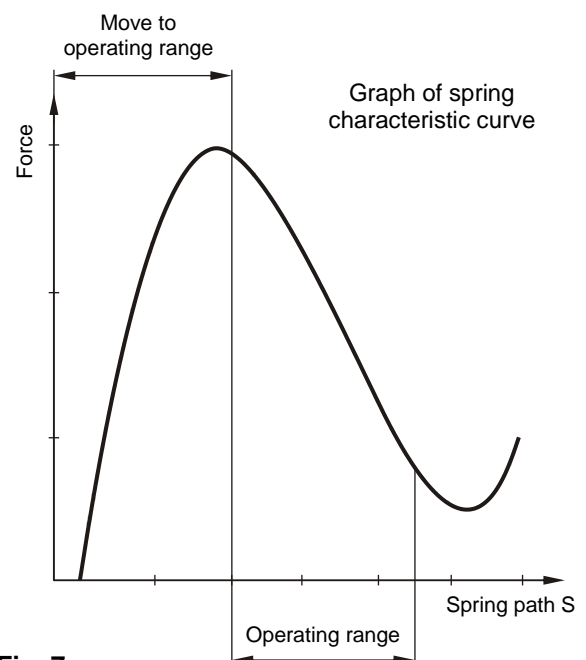

Fig. 7

Installation and Operational Instructions for EAS[®]- HTL housed overload clutch Sizes 01 – 3 Type 490._24.0

(B.4.15.1.EN)

Contactless Limit Switch (Item 12, Fig. 1)

Technical Data

Switching element function	PNP NO contact
Real distance S_r :	1,5 mm \pm 10 %
Working distance S_a :	0 – 1,2 mm
Switching hysteresis H:	1 – 15 % of S_r
Reproducibility R:	\leq 5 % of S_r
Reproducibility R: (at a constant operating voltage and temperature)	\pm 0,01 mm
Ambient temperature T_a :	-25 °C / +70 °C
Temperature drift of the switch-on point:	\leq 10 % of S_r
Nominal voltage:	24 VDC
Operating voltage U_b :	10 V – 30 V
incl. residual ripple content SS:	\leq 15 %
Current carrying capacity I_a :	\leq 200 mA
Permitted load capacitance:	\leq 1,0 μ F
Output resistance R_a :	1,9 + D + LED [k Ω]
Residual current I_r :	\leq 80 μ A
Line voltage drop U_{σ} at I_a max. :	\leq 2,5 V
Switching frequency f:	\leq 1500 Hz
Own current consumption damped / undamped:	\leq 25 mA / \leq 12 mA
Housing material:	Stainless steel
Ambient temperature	-25 ... 70 °C (248 ... 343 K)
Connection type:	LIFY-11Y.O / 3 x 0,14 mm ²
Protection acc. DIN 40050:	IP67
Weight:	65 g

Dimensions

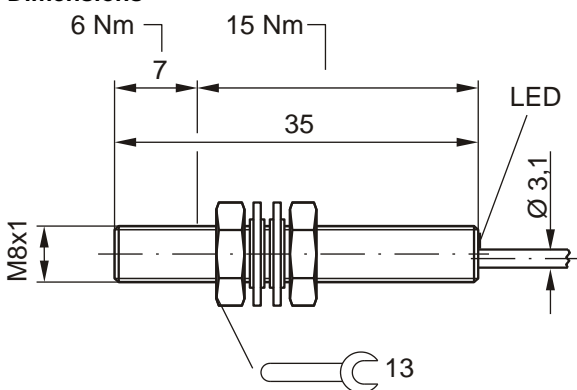

Wiring diagram

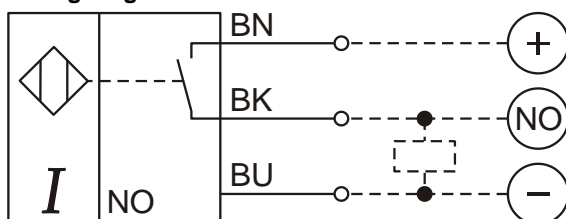

Adjustment

The limit switch (PNP NO contact; Item 12) for the EAS[®]-HTL clutch has been adjusted and countered manufacturer-side. However, as the final clutch position is defined via the customer-side attachment, re-adjustment may be necessary.

This is carried out as follows:

- Loosen the counter nut on the limit switch. Screw in the limit switch up to its limit (limit switch damped).
- Unscrew the limit switch until it switches (limit switch undamped).
- Screw in the limit switch again carefully until it switches (limit switch is damped again), then continue for another 90°.
- Counter the limit switch.
- Check the switching function by disengaging the clutch.



In order to secure limit switch function, please keep it free from oil, grease and other dirt particles.

Maintenance

The EAS[®]-HTL clutches are mainly maintenance-free. Special maintenance work may be necessary, however, if the device is operating in extreme ambient conditions. In this case, please contact the manufacturers.

Disposal

Electronic components

(Limit switch):

Products which have not been disassembled can be disposed of under Code No. 160214 (mixed materials) or components under Code No. 160216, or can be disposed of by a certified disposal firm.

All steel components:

Steel scrap (Code No. 160117)

All aluminium components:

Non-ferrous metals (Code No. 160118)

Seals, O-rings, V-seals, elastomers:

Plastic (Code No. 160119)

Installation and Operational Instructions for EAS[®] - HTL housed overload clutch Sizes 01 – 3 Type 490._24.0

(B.4.15.1.EN)

Malfunctions / Breakdowns

Malfunction	Possible Causes	Solutions
Premature clutch release	Incorrect torque adjustment	<ol style="list-style-type: none"> 1) Set the system out of operation 2) Check the torque adjustment 3) Secure the adjusting nut 4) If the cause of malfunction cannot be found, the clutch must be inspected at the place of manufacture
	Adjusting nut has changed position	
	Worn clutch	
Clutch does not release on overload	Incorrect torque adjustment	<ol style="list-style-type: none"> 1) Set the system out of operation 2) Check whether foreign bodies influence the disengagement mechanism function 3) Check the torque adjustment 4) Secure the adjusting nut 5) If the cause of malfunction cannot be found, the clutch must be inspected at the place of manufacture
	Adjusting nut has changed position	
	Disengagement mechanism blocked by a foreign body	
	Worn clutch	
Running noises on overload occurrence as clutch slows down	Bearing on output flange is worn or has been previously damaged	<ol style="list-style-type: none"> 1) Set the system out of operation 2) Inspect the clutch at the place of manufacture
	Housing bearing is worn or has been previously damaged	
	Worn disengagement mechanism	
Running noises in normal operation	Insufficient clutch securement	<ol style="list-style-type: none"> 1) Set the system out of operation 2) Check the clutch securement 3) Check the screw tightening torques 4) Check the torque adjustment and that the adjusting nut sits securely
	Loosened screws	
	Loosened adjusting nut	



mayr[®] will take no responsibility or guarantee for replacement parts and accessories which have not been delivered by *mayr*[®], or for damage resulting from the use of these products.